

# Manufacturer's Declaration of Conformity

This product has been manufactured in accordance with the Harmonized European standards, following the provisions of the below stated directives:

	93/42/EEC as amended by 2007/47/EC Medical Device Directive
--	--

*Please see separate document showing on sticker of device for above CE marking.*

Authorized EU Representative:



**Obelis s.a.**

Bd Général Wahis, 53  
B-1030 Brussels  
Belgium

Manufactured by:



**Charder Electronic Co., Ltd.**  
**No.103, Guozhong Rd., Dali Dist.,**  
**Taichung City 412, Taiwan (R.O.C.)**

**charder**®



**MS4640**

**(DP3710)**

**Stand-on Floor Scale**

**USER MANUAL**

CD-IN-1276(8650) [14221G]

*Please keep the instruction manual at hand all the time for future reference*

# **TABLE OF CONTENTS**

PREFACE.....	2
GENERAL INFORMATION.....	2
INTENDED USE.....	2
SAFETY INSTRUCTION.....	2
ENVIROMENTAL.....	3
CLEANING.....	3
MAINTENANCE.....	4
WEIGHING OPERATION.....	4
WARRANTY-LIABILITY.....	4
DISPOSING OF THE SCALE.....	5
EXPLANATION OF THE GRAPHIC SYMBOLS.....	6
EMC guidance and manufacturer's declaration.....	7
SPECIFICATION.....	13
POWER ADAPTOR STANDARDS.....	15
PANEL.....	16
KEY FUNCTION.....	17
LCD SYMBOL DESCRIPTION.....	18
TIME SETTING.....	19
USING SCALE.....	19
USING HOLD FUNCTION.....	20
USING BMI FEATURE.....	21
USING TARE FUNCTION.....	22
USING INTERNAL SETTING.....	23
STORING AND RE-CALLING PRE-TARE WEIGHT.....	24
PRINTING FUNCTION.....	28
WIRELESS CONNECTION.....	31
ASSEMBLY OF DP3700/3710 BRACKET.....	32
INSTRUCTION FOR CHARGING AND CONNECTING.....	33
USING RECHARGEABLE BATTERY (OPTIONAL).....	34
INSTRUCTION FOR BATTERY INSTALLATION.....	35
ERROR MESSAGE.....	38

## **PREFACE**

Thank you for choosing CHARDER MEDICAL product. All features of this product were designed to state of the art and are optimized for simple and straightforward use. If you have any queries or experience any problems not addressed in the operating instructions, please contact your CHARDER MEDICAL service partner, or visit us on the Internet at [www.chardermedical.com](http://www.chardermedical.com)

## **GENERAL INFORMATION**

We strongly recommend you use the scales on flat and hard surface. Any soft surface, like carpet will cause inaccuracy.

## **INTENDED USE**

This scale is intended for use to determine the weight of patients, supported by professional personnel and in rooms intended for carrying out healthcare. The weighing value can be read after a stable weighing value has been obtained. Before use, the scale must be checked by an authorised person to ensure it's in a suitable condition.

## **SAFETY INSTRUCTION**



Before putting the device into use, please read with care the information given in the Operating Instructions. They contain important instructions for installation, proper use and maintenance of the device.

The manufacturer shall not be liable for damages arising out of failure to heed the following instructions:

- These batteries should be kept away from small children. If swallowed, promptly seek medical assistance.
- Expected Service Life: 5 years
- When using electrical components under increased safety requirements, always comply with the appropriate regulations.
- Improper installation will render the warranty null and void.
- Ensure the voltage marked on the power supply unit matches

your main power supply.

- This device is designed for use indoors.
- Observe the permissible ambient temperatures for use
- The device meets the requirements for electromagnetic compatibility. Do not exceed the maximum values specified in the applicable standards.

If you have any problem, contact your local CHARDER MEDICAL service partner.

## **ENVIROMENTAL**

- ◆ All batteries contain toxic compounds; disposal of batteries should be delegated to a competent organisation, complying with the deposit of Poisonous Waste Regulation 1972.
- ◆ Please do not incinerate batteries.
- ◆ The optimum operating temperature for the scale is 0°C to +40°C (DP3710); although it will operate at higher and lower temperatures the scales battery life will be adversely effected.

## **CLEANING**

- ◆ We would recommend using alcohol based wipes or similar when cleaning the scales.
- ◆ Please do not use large amounts of water when cleaning the scales as this will cause damage to the scales electronics, you should also refrain from using corrosive liquids or high pressure washers.
- ◆ Always disconnect the scales from the mains power supply before cleaning.

## **MAINTENANCE**

♦ The scale does not require any routine maintenance. However, we recommend checking the scale's accuracy at regular intervals. The regularity of these checks is dependent on the level of use and the state of the scale. If any inaccuracies occur, please contact your local dealer or CHARDER MEDICAL service partner.

## **WEIGHING OPERATION**

Before reading detailed instructions on how to use all the weighing functions that are built into your scale, please read the following important guidelines:

- ♦ Always be sure that the display shows `Zero` before use, if it does not then please press the ZERO key.
- ♦ The device is designed to detect when a stable weight is achieved, the indicator will `bleep` twice to indicate a stable weight value, your reading should be taken at this point.

## **WARRANTY-LIABILITY**

- ♦ If a fault or defect is present on receipt of the unit which is within CHARDER MEDICAL's scope of responsibility, CHARDER shall have the right to either repair the fault or supply a replacement unit. Replaced parts shall be the property of CHARDER. Should the fault repairs or replacement delivery not be successful, the statutory provisions shall be valid. The period of warranty shall be two years, beginning on the date of purchase. Please retain your receipt as proof of purchase. Should your scale require servicing, please contact your dealer or CHARDER MEDICAL Customer Service.
- ♦ No responsibility shall be accepted for damage caused through any of the following reasons: Unsuitable or improper storage or use, incorrect installation or commissioning by the owner or third parties,

natural wear, changes or modifications, incorrect or negligent handling, overuse, chemical, electrochemical or electrical interference or humidity, unless this is attributable to negligence on the part of CHARDER MEDICAL.







◆ If operating, climatic or any other influences lead to a major change in conditions or material quality, the treaty for perfect unit functioning shall be rendered null and void. If CHARDER provides and individual warranty, this means that the unit supplied will be free of faults for the length of the warranty period.

### DISPOSING OF THE SCALE

◆ This product is not to be treated as regular household waste, but should be handed in to an electrical/electronic equipment recycling centre.

◆ You can obtain further details from your local council, your municipal waste disposal company or the firm which you purchased the product.

### ERROR MESSAGE

ERROR MESSAGE	REASON	ACTION
	Low Battery: This warning shows that the voltage of battery is too low to use.	Please replace a new battery or plug the AC adaptor for operation.
	Overload: The total load exceeds the maximum capacity of scale.	Please reduce the loading and try again.
	Counting error(too high): Indicates that the signal from the loadcell is too high.	This error is normally caused by a serious fault on the scales such as a faulty loadcell or wiring. Please contact the local service representatives.
	Counting error(too low): Indicates that the signal from the loadcell is too low.	This error is normally caused by a serious fault on the scales such as a faulty loadcell or wiring. Please contact the local service representatives.
	Zero count over calibration zero range +10% while power on.	Please re-calibrate the instrument.
	Zero count under calibration zero range -10% while power on.	Please re-calibrate the instrument.
	EEPROM Error: Indicates that there is a fault with the scales software.	This error is normally caused by a serious fault on the scales such as a faulty loadcell or wiring. Please contact the loadcell service representatives.

6.

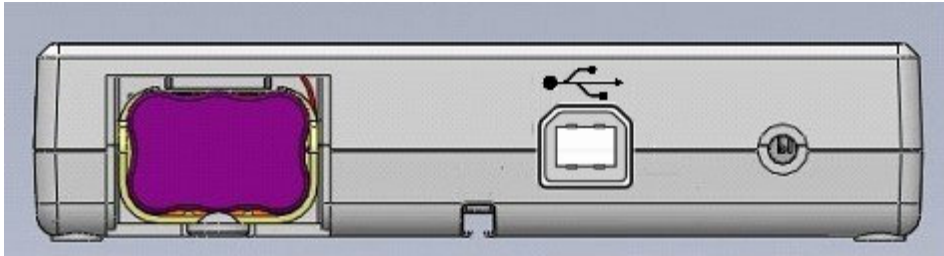

Slide back the cover to close the battery housing compartment. Then switch on the power button on the panel to see if the battery housing is correctly installed with good battery lifetime.

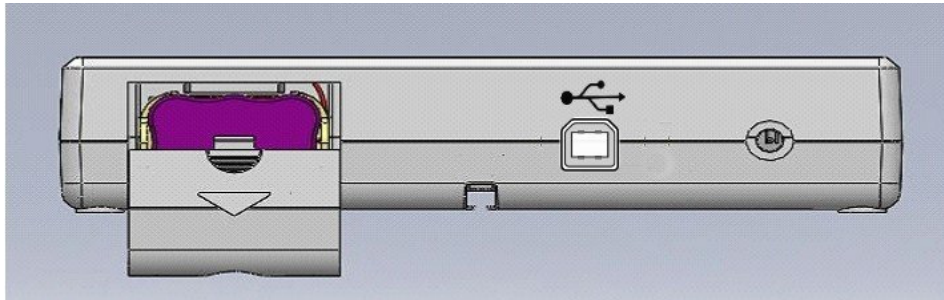

## EXPLANATION OF THE GRAPHIC SYMBOLS

**SN-T13000001**

Designation of the serial number of every device, applied at the device.

(Number as an example)

“Please note the accompanying documents”  
or “Observe operating instructions”



Identification of manufacturer of medical product including address



**Charder Electronic Co., Ltd.**  
No.103, Guozhong Rd., Dali Dist.,  
Taichung City 412, Taiwan (R.O.C.)

“Electro-medical appliance”  
with attachment for type B



Dispose of old appliances  
separately from your household  
waste!!!  
Instead, take them to communal  
collection points.



Carefully read this operation manual  
before setup and commissioning,  
even if you are already familiar with  
Charder scales.



## EMC guidance and manufacturer's declaration

Guidance and manufacturer's declaration-electromagnetic emissions		
The MEDICAL SCALE MS4640 is intended for use in the electromagnetic environment specified below. The customer or the user of the MEDICAL SCALE MS4640 should assure that it is used in such an environment.		
Emission test	Compliance	Electromagnetic environment-guidance
RF emissions CISPR 11	Group 1	The MEDICAL SCALE MS4640 uses RF energy only for its internal function. Therefore, its RF emissions are very low and are not likely to cause any interference in nearby electronic equipment.
RF emissions CISPR 11	Class B	The MEDICAL SCALE MS4640 is suitable for use in all establishments, including domestic establishments and those directly connected to the public low-voltage power supply network that supplies buildings used for domestic purposes.
Harmonic emissions IEC 61000-3-2	Class A	
Voltage fluctuations /flicker emissions IEC 61000-3-3	Compliance	

4.

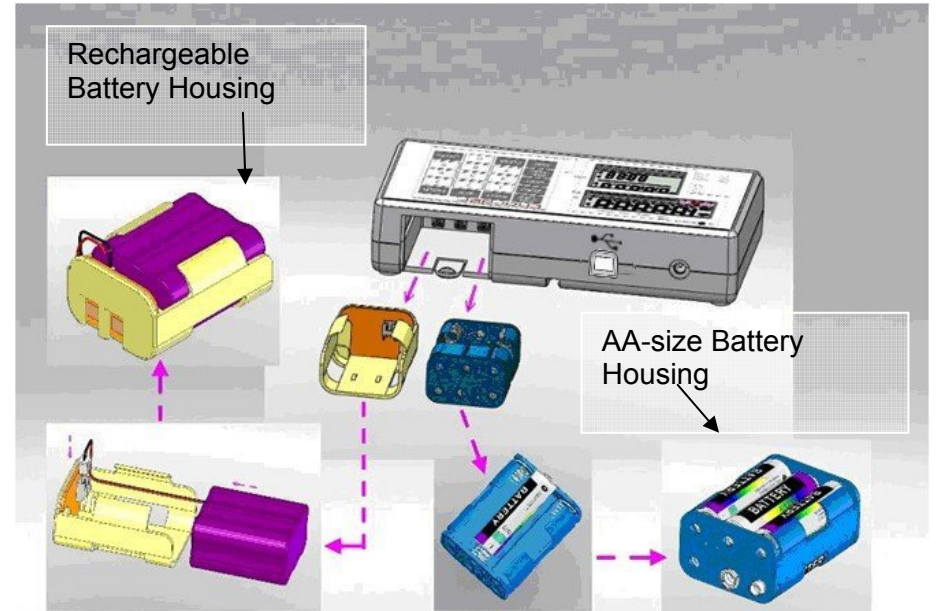

Make sure all batteries are installed into the housing with correct position

5.

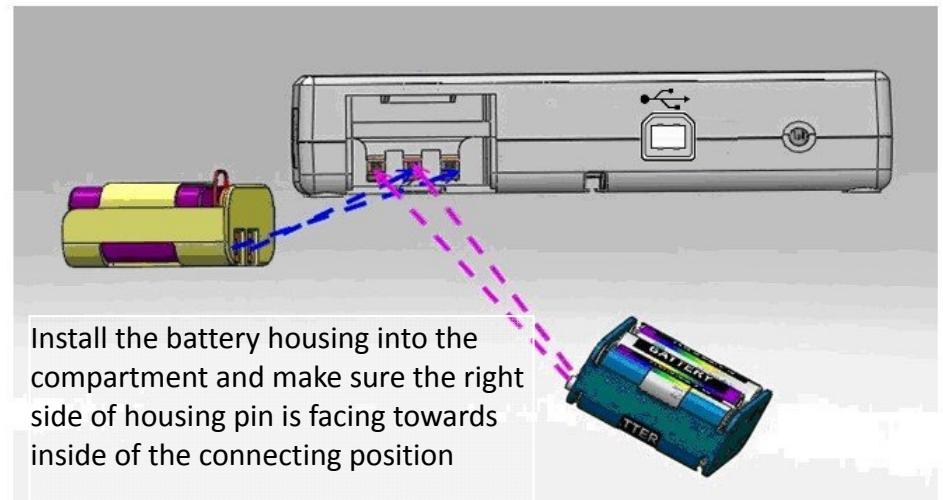

Install the battery housing into the compartment and make sure the right side of housing pin is facing towards inside of the connecting position



## INSTRUCTION FOR BATTERY INSTALLATION

1.

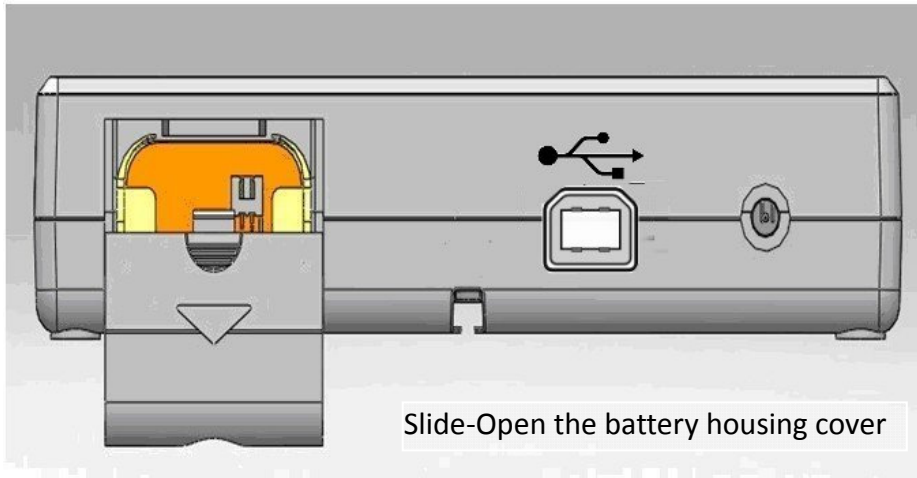

2.

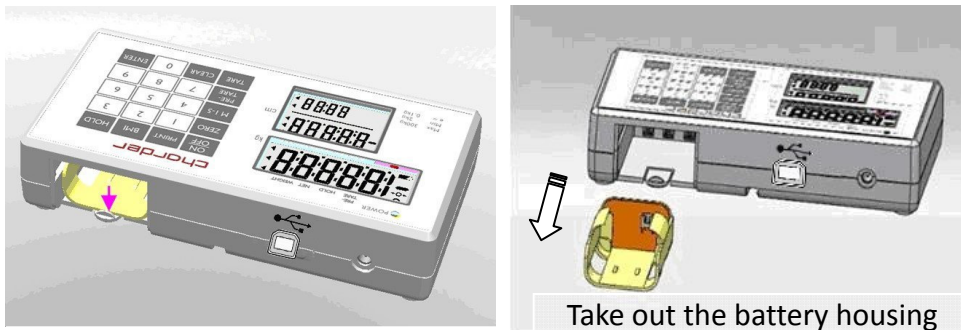

3.

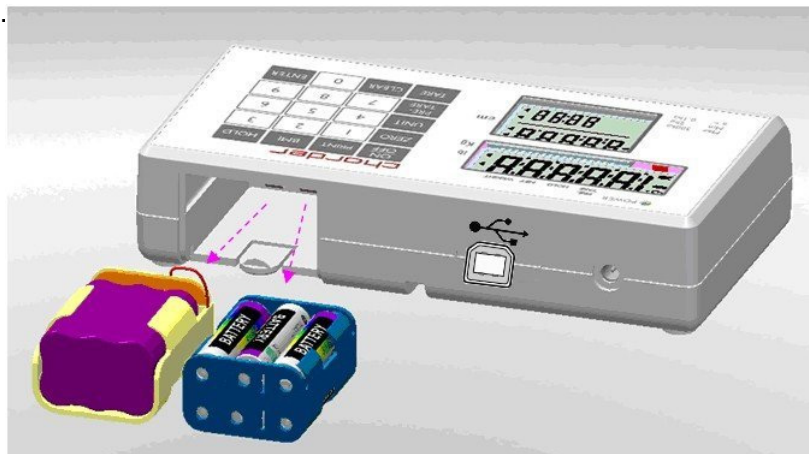

**Guidance and manufacturer's declaration-electromagnetic immunity**  
 The MEDICAL SCALE MS4640 is intended for use in the electromagnetic environment specified below.  
 The customer or the user of the MEDICAL SCALE MS4640 should assure that it is used in such an environment.

Immunity test	IEC 60601 test level	Compliance level	Electromagnetic environment-guidance
Electrostatic discharge(ESD) IEC 61000-4-2	$\pm 8$ kV contact $\pm 2$ kV, $\pm 4$ kV, $\pm 8$ kV, $\pm 15$ kV air	$\pm 6$ kV contact $\pm 8$ kV air	Floors should be wood, concrete or ceramic tile. If floors are covered with synthetic material, the relative humidity should be at least 30%
Electrical fast transient/burst IEC 61000-4-4	$\pm 2$ kV for power supply lines + 1kV for input/output lines	$\pm 2$ kV for power supply lines Not applicable	Mains power quality should be that of a typical commercial or hospital environment.
Surge IEC 61000-4-5	$\pm 1$ kV line(s) to line(s) $\pm 2$ kV line(s) to earth	$\pm 1$ kV differential mode Not applicable	Mains power quality should be that of a typical commercial or hospital environment.
Voltage Dips, short interruptions and voltage variations on power supply input lines IEC 61000-4-11	0% UT for 0,5 cycle 0% UT for 1 cycle 70% UT(30% dip in UT) for 25 cycles 0% UT for 5 s	<5% UT(>95% dip in UT) for 0,5 cycle 40% UT(60% dip in UT) for 5 cycles 70% UT(30% dip in UT) for 25 cycles <5% UT(>95% dip in UT) for 5 s	Mains power quality should be that of a typical commercial or hospital environment. If the user of the MEDICAL SCALE MS4640 requires continued operation during power mains interruptions, it is recommended that the MEDICAL SCALE MS4640 be powered from an uninterruptible power supply or a battery.

Power frequency(50/60 Hz) magnetic field IEC 61000-4-8	30 A/m	3 A/m	The MEDICAL SCALE MS4640 power frequency magnetic fields should be at levels characteristic of a typical location in a typical commercial or hospital environment.
NOTE UT is the a.c. mains voltage prior to application of the test level.			

## USING RECHARGEABLE BATTERY (OPTIONAL)

The rechargeable battery should be recharged at least every 3 months regardless if it is used or not. After a long period in storage, e.g. over 3 months, the battery should run a full cycle (charge/discharge) to allow it to restore to full capacity.

Make sure the rechargeable battery housing is installed properly and insert with the right position into the compartment

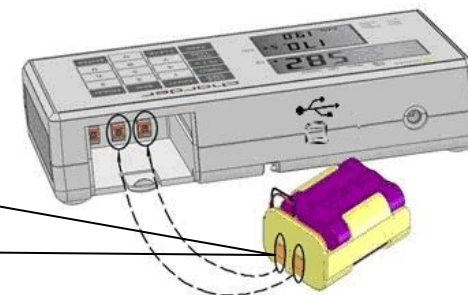

Guidance and manufacturer's declaration-electromagnetic immunity			
The MEDICAL SCALE MS4640 is intended for use in the electromagnetic environment specified below. The customer or the user of the MEDICAL SCALE MS4640 should assure that it is used in such and environment.			
Immunity test	IEC 60601 test level	Compliance level	Electromagnetic environment-guidance
Conducted RF IEC 61000-4-6	3 Vrms 150 KHz to 80 MHz  6 V in ISM bands between 0,15 MHz and 80 MHz 80 % AM at 1 kHz	3 Vrms	Portable and mobile RF communications equipment should be used no closer to any part of the MEDICAL SCALE MS4640 including cables, than the recommended separation distance calculated from the equation applicable to the frequency of the transmitter.  <b>Recommended separation distance:</b> $d = 1,2 \sqrt{P}$ $d = 1,2 \sqrt{P}$ 80MHz to 800 MHz $d = 2,3 \sqrt{P}$ 800MHz to 2,7 GHz  Where $P$ is the maximum output power rating of the transmitter in watts ( $W$ ) according to the transmitter manufacturer and $d$ is the recommended separation distance in metres (m).
Radiated RF		3 V/m	Field strengths from fixed RF

## INSTRUCTION FOR CHARGING AND CONNECTING

If **Lo** prompt displays on the LCD, please charge the scale with MS 4640 exclusive adaptor or replace the batteries.  
**Locate adaptor plug on the right side of indicator.**

### DP3710 display

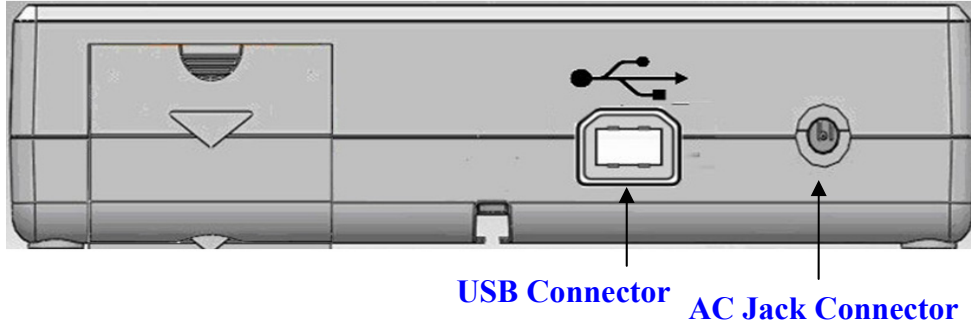

### DP3700 display

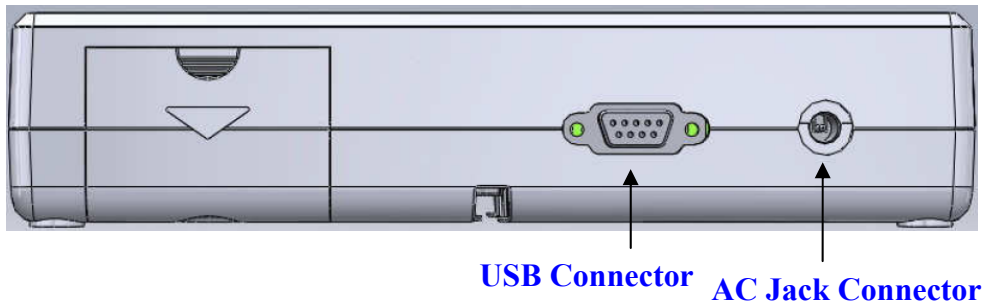

### CAUTION:

Always connect the AC adaptor with the indicator before connecting to the mains power supply.  
 Please disconnect the adaptor from main power supply before remove the plug from indicator.

IEC 61000-4-3

3 V/m 80MHz to 2,7 GHz

transmitters, as determined by an electromagnetic site survey<sup>a</sup>, should be less than the compliance level in each frequency range<sup>b</sup>.

Interference may occur in the vicinity of equipment marked with the following symbol:



NOTE1 At 80 MHz and 800 MHz, the higher frequency range applies.

NOTE2 These guidelines may not apply in all situations. Electromagnetic propagation is affected by absorption and reflection from structures, objects and people.

a Field strengths from fixed transmitters, such as base stations for radio (cellular/cordless) telephones and land mobile radios, amateur radio, AM and FM radio broadcast and TV broadcast cannot be predicted theoretically with accuracy. To assess the electromagnetic environment due to fixed RF transmitters, an electromagnetic site survey should be considered. If the measured field strength in the location in which the MEDICAL SCALE MS4640 is used exceeds the applicable RF compliance level above, the MEDICAL SCALE MS4640 should be observed to verify normal operation. If abnormal performance is observed, additional measures may be necessary, such as re-orienting or relocating the MEDICAL SCALE MS4640.

b Over the frequency range 150 kHz to 80 MHz, field strengths should be less than 3 V/m.



### Recommended separation distance between portable and mobile RF communications equipment and the MEDICAL SCALE

The MEDICAL SCALE MS4640 is intended for use in an electromagnetic environment in which radiated RF disturbances are controlled. The customer or the user of the MEDICAL SCALE MS4640 can help prevent electromagnetic interference by maintaining a minimum distance between portable and mobile RF communications equipment (transmitters) and the MEDICAL SCALE MS4640 as recommended below, according to the maximum output power of the communications equipment.

Rated maximum output power of transmitter W	Separation distance according to frequency of transmitter m		
	150 kHz to 80 MHz $d = 1,2\sqrt{P}$	80 MHz to 800 MHz $d = 1,2\sqrt{P}$	800 MHz to 2,7 GHz $d = 2,3\sqrt{P}$
0,01	0,12	0,12	0,23
0,1	0,38	0,38	0,73
1	1,2	1,2	2,3
10	3,8	3,8	7,3
100	12	12	23





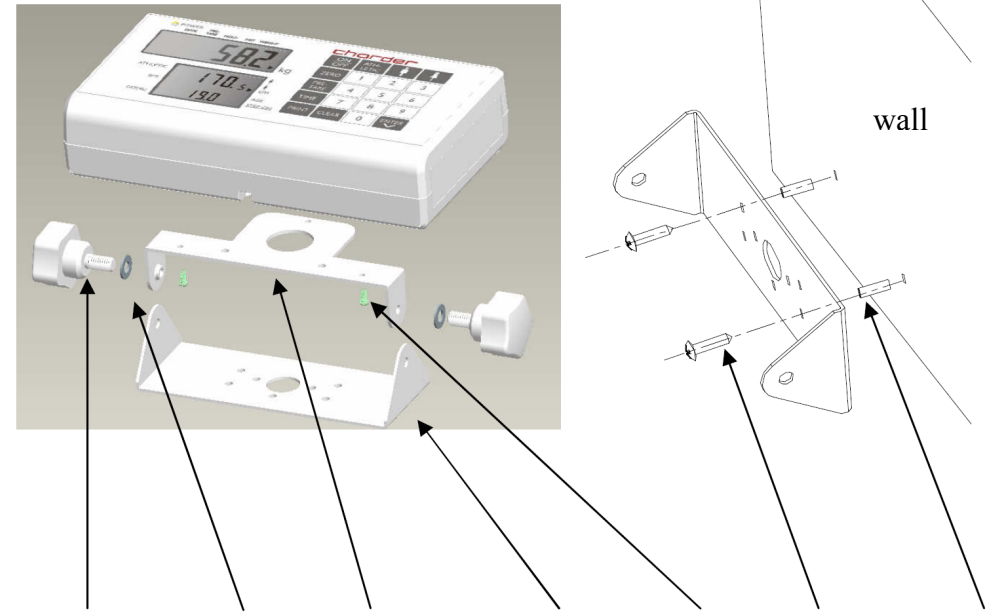

For transmitters rated at a maximum output power not listed above, the recommended separation distance  $d$  in metres (m) can be estimated using the equation applicable to the frequency of the transmitter, where  $p$  is the maximum output power rating of the transmitter in watts (W) according to the transmitter manufacturer.

NOTE1 At 80 MHz and 800 MHz, the separation distance for the higher frequency range applies.

NOTE2 These guidelines may not apply in all situations. Electromagnetic propagation is affected by absorption and reflection from structures, objects and people.

### ASSEMBLY OF DP3700/3710 BRACKET



						
Adjustable foot	spacer	Fixed plate (top)	Fixed plate (bottom)	Tapping Screw	Screw	Plastic anchor
2	2	1	1	2	2	2

keyboard to transmit a print command to printout from the thermal printer on the CHARDER scale for hard copy of weighing data & BMI.

Or, press the [PRINT] button on the display panel of the CHARDER scale, the printout presented below is the standard format print layout as well as shown on the HyperTerminal computer screen.

GROSS WEIGHT	70.00kg
TARE WEIGHT	0.00kg
NET WEIGHT	0.00kg
USER HEIGHT	170.0cm
USER B.M.I.	24.2
01/01/2013 10:00	

## WIRELESS CONNECTION

Enable the Bluetooth function on user ANDROID version 4.3+ smart phone/tablet or I-Phone IOS version is an alternative wireless transmission technology to connect with Display Head DP3710 version when there is limited working space for cable wire connections.

### Recommended separation distance between portable and mobile RF communications equipment and the MS4640

The MS4640 is intended for use in an electromagnetic environment in which radiated RF disturbances are controlled. The customer or the user of the MS4640 can help prevent electromagnetic interference by maintaining a minimum distance between portable and mobile RF communications equipment (transmitters) and the MS4640 as recommended below, according to the maximum output power of the communications equipment.

Rated maximum output power of transmitter W	Separation distance according to frequency of transmitter m		
	150 kHz to 80 MHz $d = 1,2\sqrt{P}$	80 MHz to 800 MHz $d = 1,2\sqrt{P}$	800 MHz to 2,5 GHz $d = 2,3\sqrt{P}$
0,01	N/A	0,12	0,23
0,1	N/A	0,38	0,73
1	N/A	1,2	2,3
10	N/A	3,8	7,3
100	N/A	12	23

For transmitters rated at a maximum output power not listed above, the recommended separation distance  $d$  in meters (m) can be estimated using the equation applicable to the frequency of the transmitter, where  $p$  is the maximum output power rating of the transmitter in watts (W) according to the transmitter manufacturer.

NOTE1 At 80 MHz and 800 MHz, the separation distance for the higher frequency range applies.  
NOTE2 These guidelines may not apply in all situations. Electromagnetic propagation is affected by absorption and reflection from structures, objects and people.

## SPECIFICATION

<b>Model</b>	MS 4640
<b>Display</b>	DP3710
<b>Data transfer</b>	USB (B-type)
<b>Capacity</b>	300kg x 0.1kg
<b>Accuracy</b>	±0.15kg
<b>Weight Unit</b>	kg
<b>LCD Display</b>	1.0 inch LCD display with 5 and 1/2 digits
<b>Dimension</b>	Platform size: 340 x 450 mm
<b>Key Functions</b>	ON/OFF, ZERO, PRINT, BMI, HOLD, PRE-TARE, TARE , CLEAR, ENTER, 0~9 , M1-5
<b>Power Supply</b>	<ul style="list-style-type: none"> <li>➤ 6-AA size batteries</li> <li>➤ Rechargeable battery pack (optional).</li> <li>➤ 12V AC Adaptor</li> </ul>
<b>Operation Temperature</b>	0°C ~ + 40°C(DP3710) 15% - 85% RH
<b>Standard Accessories</b>	Adjustable Feet x 2 ; spacer x 2; Fixed plate (top) x 1.;Fixed plate (bottom) x 1;Tapping Screw x 2; User manual x 1; 12V 2A Adaptor x 1; Plastic anchor x 2, Screw x 2, USB cable x 1
<b>Options</b>	Indicator stand
	AR-2491 carry bag
	TP2110 thermo printer

### 5. New Connection Description

Name the connection and click OK Button

### 6. Select COM Port on User PC

Click Connect to select COM port on the computer. Then click OK.

### 7. Port Settings for Printout

Set up as below:

- ◆ Baud rate: 9600 bps
- ◆ Parity check: None
- ◆ Data length: 8 bits
- ◆ Stop bit: 1 bit
- ◆ Handshake: RTS/CTS
- ◆ Data code: ASCII

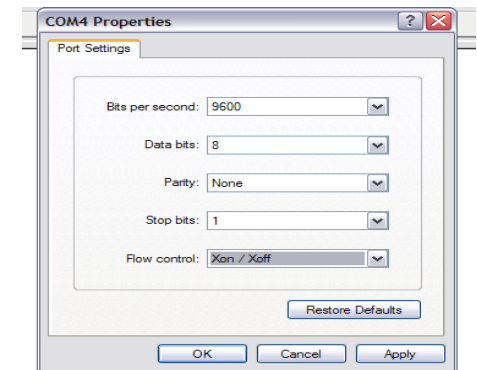
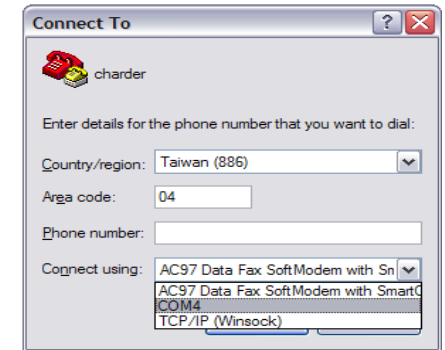

### USB Driver Install

The scale confirms to the USB PL2303

Make sure the computer software has a USB scale interface.

### PL2303 driver download:

<http://www.prolific.com.tw/US/ShowProduct.aspx?pcid=41&showlevel=0017-0037-0041>

### 8. Printout Data Through USB cable connector

Click OK button to complete the setting. The PC will retrieve the weighing & BMI data from the CHARDER scale and display on the HyperTerminal program similar to the layout below.

While the Hyper Terminal program is running, type "P" KEY on the PC



For use on Windows Vista or higher please download hyper terminal software program from Charder website:

<http://www.chardermedical.com/download/dlist-4.htm>

4. Start Hyper Terminal

After taking the weight and BMI, run Hyper Terminal program from the PC's Windows OS with the following steps:

Step.1- Click on Start Button.

Step.2- Go to All Programs.





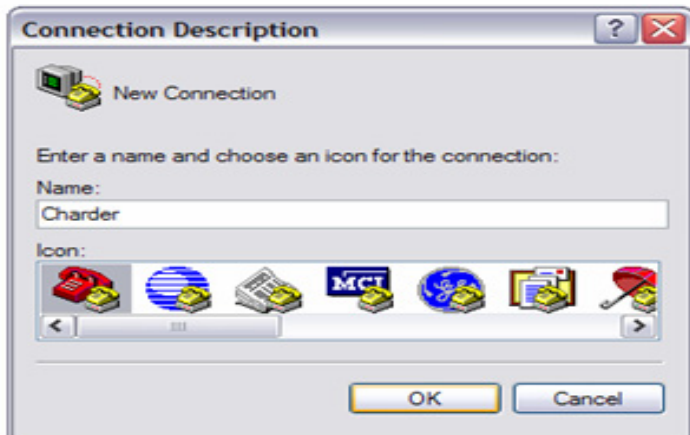
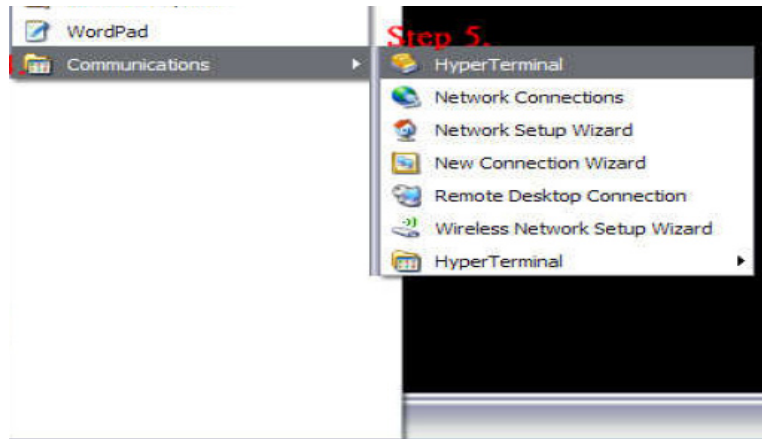

Step.3- Select Accessories.

Step.4- Find Communications.

Step.5- In Communications section click on HyperTerminal.

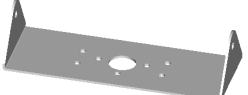

### Standard Accessories

No.	Accessories	Item	Spec.	Qty.
1		Adjustable feet	M6*15	2
2		Spacer	§ 6.6* § 13	2
3		Fixed plate (top)	SS-4961	1
4		Fixed plate (bottom)	<del>SS-4971</del>	1
5		Tapping Screw	M3*6	2
6		Plastic anchor	1"(white)	2
7		Screw	4*20	2
8		USB cable	<del></del>	1

## POWER ADAPTOR STANDARDS

⚠ CAUTION: The device is only compatible with restricted power adaptors in dashed block below.

AMP VOLTAGE	DRAWING NO.:	CE APPROVED TYPE NO. / MODEL NO.:	TYPE
9V DC 100mA	AD-0484	D35W090100-23/1	US
9V DC 100mA	AD-038A	D41W1090100-13/1	EU
9V DC 100mA	AD-037A	D41WK090100-23/2	UK
9V 200mA	AD-8082(AD-0544)	UE05WCP-090020SPC	US
9V 200mA	AD-8082(AD-0544)	UE05WCP-090020SPC	EU
9V 200mA	AD-8082(AD-0544)	UE05WCP-090020SPC	UK
9V 200mA	AD-8082A(AD-0544A)	UE05WCP-090020SPC	AU
15V 300mA	AD-016D	D41W150300-13/1	US
15V 300mA	AD-0420	D41W150300-13/1	EU
15V 300mA	AD-0370	D41WK150300-23/2	UK
15V 300mA	AD-0482	D41WA150300-13/2	AU
15V300mA	AD-8079D(AD-0536D)	UE05WCP-150030SPC	US
15V300mA	AD-8079A(AD-0536A)	UE05WCP-150030SPC	EU
15V300mA	AD-8079B(AD-0536B)	UE05WCP-150030SPC	UK
15V300mA	AD-8079C(AD-0536C)	UE05WCP-150030SPC	AU
12V 1A	AD-8084B	UE24WV-120100SPA	EU
12V 1A	AD-8084	UE24WB-120100SPA	UK
12V 1A	AD-8095	UE24WCP1-120100SPA	US
12V 1A	AD-8095	UE24WCP1-120100SPA	EU
12V 1A	AD-8095	UE24WCP1-120100SPA	UK
12V 1A	AD-8095	UE24WCP1-120100SPA	AU
12V 2A	AD-8058(AD-0521)	UE24WU-120200SPA	US
12V 2A	AD-8057(AD-0520)	UE24WV-120200SPA	EU
12V 2A	AD-8056(AD-0519)	UE24WB-120200SPA	UK
12V 2A	AD-8074(AD-0534)	UE24W4-120200SPAS	AU
12V 1A	AD-8096	UE24WCP1-120100SPA	US
12V 1A	AD-8096	UE24WCP1-120100SPA	EU
12V 1A	AD-8096	UE24WCP1-120100SPA	UK
12V 1A	AD-8096	UE24WCP1-120100SPA	AU
12A 1.5A	AD-8025A(AD-0527)	GFP181DA-120150B-2	US
12A 1.5A	AD-8025D(AD-0529)	GFP181DA-120150B-2	UK

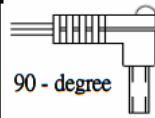

90 - degree



180 - degree

## PRINTING FUNCTION

The Weighing, BMI and Height results can be printed for hard copy records by pressing PRINT button on CHARDER Scale display panel.

The format presented below is the standard format of results print-out and cannot be changed.

GROSS WEIGHT 60.00kg  
TARE WEIGHT 30.00kg  
NET WEIGHT 30.00kg  
PATIENT HEIGHT 100.0cm  
PATIENT B.M.I 37.5  
  
29/12/2008 17:00

### HOW TO SETUP USB CONNECTIONS ON PC (DP3710 only)



1. Make sure the PC hardware device has USB port version 2.0 or above compatibility. Users may need to consult with local computer accessories dealer to select the proper USB cable length that is most suitable to work environment for best performance, then connect the cable first between the PC and CHARDER Scale model.
2. Run HyperTerminal program under Windows OS computer and input printer port parameter settings, please refer to the next Section in <Step 7> on how to setup HyperTerminal program in user's computer for printer port parameters.
3. Once the HyperTerminal setting is ready, make sure the USB cable is connected properly between the user PC's USB port and the CHARDER Scale Model again. Press PRINT button on the Scale Display Panel for printout of weight & BMI data from thermal printer

### Hyper Terminal setting in PC for printout

Hyper Terminal is a freeware on PC Windows XP SP3 or lower to setup the PC printer com-port with USB cable connector transmission.



### C. RECALL PRE-TARE VALUE

DESCRIPTION	EXAMPLE
<p>Long press PRE-TARE key for 3 seconds; the display will recall the memory saved for the pre-tare value starting from “m1” up to “m5”. The pre-tare value will blink.</p>	
<p><b>Enter numerical keys 1 ~ 5 to recall a memory pre-tare value</b></p>	
<p>Press <b>[ENTER]</b> key to perform the minus subtraction of the pre-tare weight recalled from the memory; Place the actual weight onto the platform at this step, the scale instrument will automatically perform tare function to produce true weight value.</p>	
<p>Press <b>[Clear]</b> key to return to Normal Weighing Mode.</p>	

### PANEL

DP3700



DP3710 (Wireless optional)

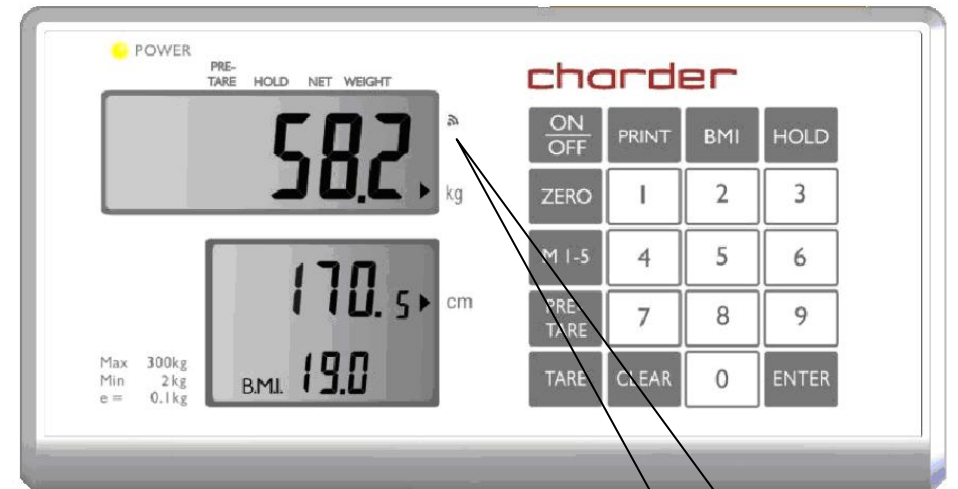

WIRELESS SYMBOL

## KEY FUNCTION

Key	Description
ON/OFF	Turn ON/OFF the scale
PRINT	Data transmission via interface(Print-out the results)
BMI	To determine Body Mass Index
HOLD	To determine stable weighing value in case of unstable weight.
ZERO	To reset the display to 0.0kg display / Zero the scale ( $\pm 2\%$ of full capacity)
M1-5	To store 5 pre-tare values (Approval Model).
PRE-TARE	Pre-tare function for subtraction of a known container weight or any other object before weighing process.
TARE	Tare allows the user to zero the instrument to cancel the weight of a container/ clothes from the reading of the instrument, thus giving the true weight of the product/ person being tested, while weighing.
CLEAR	To clear the wrong entry while entering digits.
ENTER	To confirm the performing functions.
0-9	Entering digits

Press **[ENTER]** to save each pre-tare weight value into the memory, thus the scale instrument will make beep sound to confirm changes.







Press **[Clear]** to go back to normal mode & perform the next new weighing.



**Press [CLEAR] key to correct digits in case if mistakes are made in typing; blinking zero will be shown on screen again.**

## B. Enter Weight Using 0~9 Keys:

DESCRIPTION	EXAMPLE
<p>Press <b>[PRE-TARE]</b> key, the default value of 50kg will blink in the upper LCD screen.</p> <p>NOTE: It will return to normal mode after 6 seconds if no weighing objects are placed onto the platform loadcells.</p>	
<p>Manually enter numerical 0~9 key digits as the required pre-tare weight. For example: 5kg. Enter the key digits from left to right and then press <b>[ENTER]</b> to save it.</p>	
<p>The display will show the minus sign of the manually entered pre-tare value while the platform is cleared without any weight on it.</p>	
<p>Press <b>[M1-5]</b> key; the blinking 'm' sign will appear on the LCD screen as memory function to save the pre-tare value.</p>	
<p>Press numeral key digits 1 ~ 5 to assign up to 5 memories of pre-tare values for the next weighing of true weight.</p>	

## LCD SYMBOL DESCRIPTION

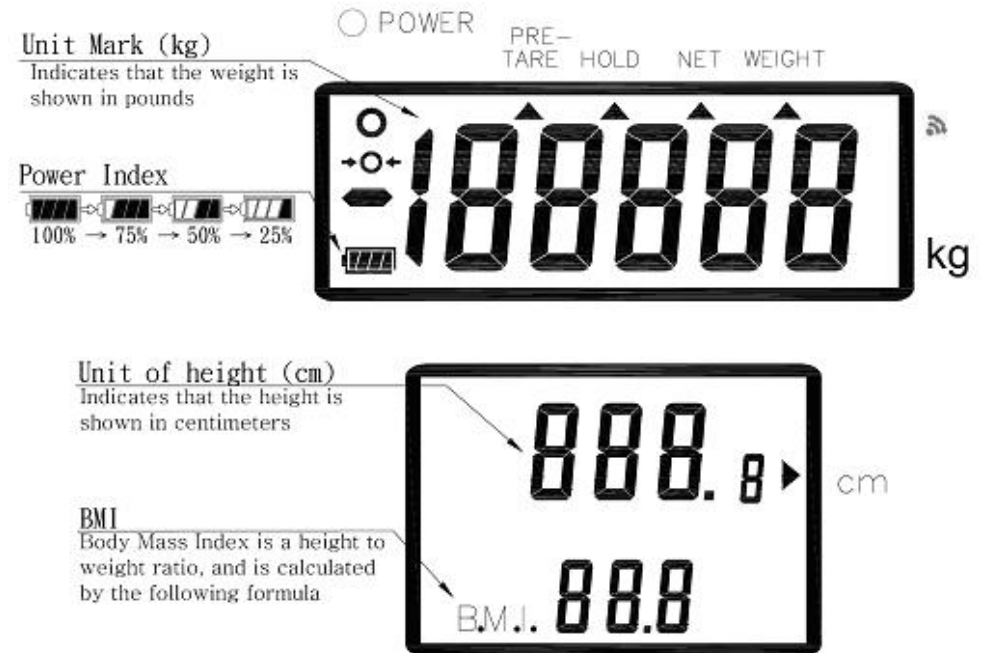

**Unit Mark (kg)**  
Indicates that the weight is shown in pounds

**Power Index**  
100% → 75% → 50% → 25%

**Unit of height (cm)**  
Indicates that the height is shown in centimeters

**BMI**  
Body Mass Index is a height to weight ratio, and is calculated by the following formula

## Definitions

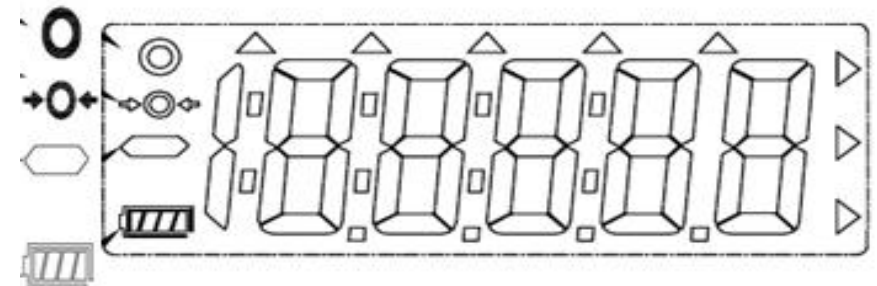

- **Stable symbol:** To indicate that the weight is stable.
- **Minus weight:** Weight under zero.
- +○+ **Zero symbols:** Weight is at zero point.
- ▢ **Low battery:** Battery need to charge or replaced with new ones.



## TIME SETTING

Long press HOLD key for 3 seconds to enter the TIME SETTING mode, beginning with the top row, with the flashing digit. Press HOLD key after successful change to move to next step.

EX: To input Dec 25, 2008, 8:00am.

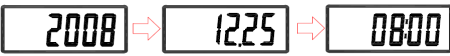
	Enter year using keys from 0~9. Press HOLD key after successful entry to move to next.
	Enter date. Ex: 12/25 enter "12.25" Press HOLD key after successful entry to move to next.
	Enter time.
	Display Format YYYY→MM.DD→TT:SS

## USING SCALE

- ◆ Switch on the scale using  key. The diagnostic scale self-check is performed and the software version is displayed.
- ◆ The „0,00 kg” weight displays on the screen, now the scale is ready for weighing.

Note: If „0,00 kg” won't display on the screen, press  key to

zero the scale,  can be used any time to zero the scale.

- ◆ Place a person in the middle of the scale. Wait until the scale stabilizes and stable sign (o) shows on the screen

### Direction:



If a person is heavier than the scale capacity, the display will show the „Err” prompt (= overload).

**Note:** To apply the changes proceed by pressing [TARE] until “END” is displayed on the screen, and then press [HOLD] to confirm changes.

## STORING AND RE-CALLING PRE-TARE WEIGHT

This scale model can store up to 5 sets of pre-tare values, and there are two methods to store pre-tare value – *Using Dead Weight or Enter weight using 0~9 numerical keys.*

### A. Using Dead Weight:

DESCRIPTION	EXAMPLE
After weighing on the platform; press key [M1-5], 'm' sign will display on lower LCD screen for memory of tare value.	
Press numerical keys from 1 ~ 5 to assign up to 5 memory tare values in advance for pre-tare weight.	
Press ENTER key to store pre-tare weight; the instrument will make beep sound to perform the next weighing function.	

## USING INTERNAL SETTING

Press [ZERO] key for 3 seconds to see mode settings ↓

HOLD key means "enter" →  
TARE key means "select" ⇕

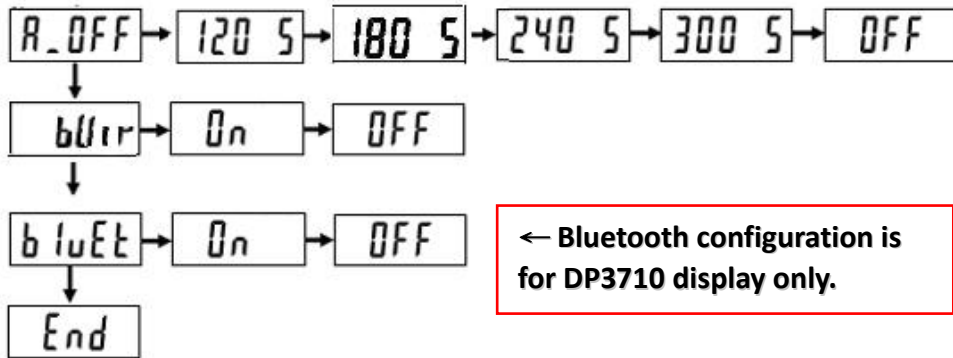

Switch ON the scale and long press [ZERO] key for 3 seconds. "SETUP" will display on LCD and then "A.OFF" is shown on the LCD successively for 3 mode settings.

### AUTO-POWER OFF TIME SETUP

Press [HOLD] to enter auto-off time setting  
120 sec / 180 sec / 240 sec / 300 sec / off

Press [HOLD] to go through selection & [TARE] key to confirm the setting.

For example: If select 240 S as auto off time, press [TARE] key until 240 S displays on the screen. Then press [TARE] to return to setting menu for other settings again.

### BUZZER ON/OFF SETUP

Press [HOLD] to enable beep sound ON/OFF and confirm by pressing [TARE].

### WIRELESS TRANSMISSION FUNCTION

Press [HOLD to Wireless: On/Off

## USING HOLD FUNCTION

Charder Medical Scale is provided with the integrated HOLD function to determine the 'locked' weight by capturing the average balance weight from the fluctuation of weighing on the platform. It enables people to be weighed accurately whenever the movements on the scale platform may not be stabilized.

**Note:** Determining average weight may not be possible in case of big fluctuation due to movements in weight.

- Press [ON/OFF] key to switch on the scale. The diagnostic self-check will be performed and wait until "0.0 kg" is displayed on the top LCD screen with 'stable' and 'zero mark' appeared on the far left side of the top LCD screen.
- Move the object/ person onto the scale platform. Press [HOLD] key. The 'HOLD' will display on the screen.
- Wait for a few seconds of blinking signal until LCD screen displays a fixed average value based on fluctuating weight, the weighing result will be a locked weight value on the LCD display.
- To release the locked weight value on display simply remove the weight substance from the platform or press the [HOLD] key again and the display will return to normal mode automatically for the next new weighing.
- Press [HOLD] key function can be before or after putting the weight on the tread platform. In case of unstable weight due to external movements on the platform, it is recommended to press [HOLD] key after the weight is positioned ready on the tread platform.

## USING BMI FEATURE

1. In normal mode, press BMI key to enter into BMI mode.
2. The lower LCD display will show a default height value blinking.
3. Enter the height value from left to right by pressing numerical keys from (0~9). (ex:170cm)
4. Proceed to weigh under normal mode. The scale LCD display will show the weight, height, and BMI value.
5. The weight and height can be changed whenever the weight on the platform is changed accordingly; CHARDER Scale is capable of calculating the BMI value according to the changed weight and height spontaneously.
6. HOLD feature can also be applied to lock the weighing value if the weight is unstable under normal weighing mode.
7. Press BMI button to return normal weighing mode again.

### Body Mass Index Categories

Classification of weight for adults over 18 years on the basis of Body Mass Index according to WHO, 2000 EK IV and WHO 2004 (WHO - World Health Organization).

Category	BMI (kg/m <sup>2</sup> )	Risk of diseases accompanying overweight
Underweight	< 18.5	low
Normal weight	18.5 – 24.9	average
Overweight	≥ 25.0	
Preobesity	25.0 – 29.9	slightly increased
I degree of obesity	30.0 – 34.9	increased
II degree of obesity	35.0 – 39.9	high
III degree of obesity	≥ 40	very high

## USING TARE FUNCTION

TARE allows the user to subtract the tare weight from the gross weight of a substance that contains the actual weight to be weighed (gross weight), thus giving the true weight (net weight) such as product package or person unable to take off certain clothing substance but requires to be weighed precisely.

- First, place the weight of a substance for tare on the tread platform.
- Press “TARE” key after the weighing becomes stabilized and stable symbol displays. Wait for the LCD display to become zero again, and then remove the tare weight from the platform.
- Place the actual weight to be weighed onto the platform (Including the same weight of the previous tare object). The LCD screen will show the actual weighing value subtracting the tare weight from it automatically.

To delete the previous saved tare value, remove the tare object from the tread platform and press “TARE” key again for the next new tare weight.