

---

charder®



MS5710 / 5711 / 5712

Medical Scale

USER MANUAL

*Please keep the instruction manual at hand all the time for future reference.*

---

# **TABLE OF CONTENTS**

PREFACE.....	2
GENERAL INFORMATION .....	2
SAFETY INSTRUCTION.....	2
ENVIROMENTAL.....	3
CLEANING.....	3
MAINTENANCE.....	3
WEIGHING OPERATION.....	4
WARRANTY-LIABILITY .....	4
DISPOSING OF THE SCALE.....	6
EXPLANATION OF THE GRAPHIC SYMBOLS .....	7
EMC GUIDANCE AND MANUFACTURER'S DECLARATION .....	9
SPECIFICATION .....	14
PANEL.....	16
KEY FUNCTION .....	17
POWER ADAPTOR STANDARDS.....	18
LCD DISPLAY SYMBOLS .....	19
USING SCALE .....	20
USING HOLD FUNCTION.....	20
USING TARE FUNCTION.....	22
USING BMI FEATURE.....	23
MS 5710/5711/5712: SET-UP.....	24
PRINT FUNCTION .....	26
STANDARD ACCESSORIES FOR MS5712.....	28
INSTRUCTION FOR CHARGING AND CONNECTING .....	30
INSTRUCTION FOR REPLACING BATTERIES .....	31
ERROR MESSAGE .....	32
TROUBLESHOOTING .....	33

## PREFACE

Thank you for choosing CHARDER MEDICAL product. All features of this product were designed to state of the art and are optimized for simple and straightforward use. If you have any queries or experience any problems not addressed in the operating instructions, please contact your CHARDER MEDICAL service partner, or visit us on the Internet at [www.chardermedical.com](http://www.chardermedical.com)

## GENERAL INFORMATION

We strongly recommend you use the scales on flat and hard surface. Any soft surface, like carpet will cause inaccuracy.

## SAFETY INSTRUCTION

 Before putting the device into use, please read with care the information given in the Operating Instructions. They contain important instructions for installation, proper use and maintenance of the device.

The manufacturer shall not be liable for damages arising out of failure to heed the following instructions:

These batteries should be kept away from small children. If swallowed, promptly seek medical assistance.

- ◆ Expected Service Life: 5 years
- ◆ When using electrical components under increased safety requirements, always comply with the appropriate regulations.
- ◆ Improper installation will render the warranty null and void.
- ◆ Ensure the voltage marked on the power supply unit matches your mains power supply.
- ◆ This device is designed for use indoors.
- ◆ Observe the permissible ambient temperatures for use
- ◆ The device meets the requirements for electromagnetic compatibility. Do not exceed the maximum values specified in

the applicable standards.

- ◆ These batteries should be kept away from all children. If swallowed, promptly seek medical assistance.

**If you have any problem, please contact your local CHARDER MEDICAL service partner.**

## **ENVIROMENTAL**

- ◆ All batteries contain toxic compounds; disposal of batteries should be delegated to a competent organisation, complying with the deposit of Poisonous Waste Regulation 1972.
- ◆ Please do not incinerate batteries.
- ◆ The optimum operating temperature for the scale is 5°C to +35°C; although it will operate at higher and lower temperatures the scales battery life will be adversely effected.

## **CLEANING**

- ◆ We would recommend using alcohol based wipes or similar when cleaning the scales.
- ◆ Please do not use large amounts of water when cleaning the scales as this will cause damage to the scales electronics, you should also refrain from using corrosive liquids or high pressure washers.
- ◆ Always disconnect the scales from the mains power supply before cleaning.

## **MAINTENANCE**

The scale does not require any routine maintenance. However, we

recommend checking the scale's accuracy at regular intervals. The regularity of these checks is dependent on the level of use and the state of the scale. If any inaccuracies occur, please contact your local dealer or CHARDER MEDICAL service partner.

## **WEIGHING OPERATION**

Before reading detailed instructions on how to use all the weighing functions that are built into your scale, please read the following important guidelines:

- ◆ Always be sure that the display shows `Zero` before use, if it does not then please press the ZERO key.
- ◆ The device is designed to detect when a stable weight is achieved, the indicator will `bleep` twice to indicate a stable weight value, your reading should be taken at this point.

## **WARRANTY-LIABILITY**

- ◆ If a fault or defect is present on receipt of the unit which is within CHARDER MEDICAL's scope of responsibility, CHARDER shall have the right to either repair the fault or supply a replacement unit. Replaced parts shall be the property of CHARDER. Should the fault repairs or replacement delivery not be successful, the statutory provisions shall be valid. The period of warranty shall be two years, beginning on the date of purchase. Please retain your receipt as proof of purchase. Should your scale require servicing, please contact your dealer or CHARDER MEDICAL Customer Service. No responsibility shall be accepted for damage caused through any of the following reasons: Unsuitable or improper storage or use,

---

incorrect installation or commissioning by the owner or third parties, natural wear, changes or modifications, incorrect or negligent handling , overuse, chemical, electrochemical or electrical interference or humidity, unless this is attributable to negligence on the part of CHARDER MEDICAL.

- ♦ If operating, climatic or any other influences lead to a major change in conditions or material quality, the treaty for perfect unit functioning shall be rendered null and void. If CHARDER provides an individual warranty, this means that the unit supplied will be free of faults for the length of the warranty period.

### **DISPOSING OF THE SCALE**

- ♦ This product is not to be treated as regular household waste, but should be handed in to an electrical/electronic equipment recycling centre.

You can obtain further details from your local council, your municipal waste disposal company or the firm which you purchased the product.

## EXPLANATION OF THE GRAPHIC SYMBOLS

**SN-T13000001**

Designation of the serial number of every device, applied at the device.

(Number as an example)



“Please note the accompanying documents”  
or “Observe operating instructions”



Identification of manufacturer of medical product including address

**Charder Electronic Co., Ltd.**

No.103, Guozhong Rd., Dali Dist.,  
Taichung City 412, Taiwan (R.O.C.)



Type B applied part





Dispose of old appliances separately from your household waste!!!

Instead, take them to communal collection points.



Carefully read this operation manual before setup and commissioning, even if you are already familiar with Charder scales.

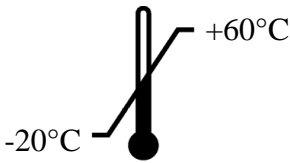

Transport and storage temperature limit indicating the upper and the lower limit

(Transport and storage temperature on packaging)

## **EMC GUIDANCE AND MANUFACTURER'S DECLARATION**

### **Guidance and manufacturer's declaration-electromagnetic emissions**

The MEDICAL SCALE MS5710 is intended for use in the electromagnetic environment specified below.

The customer or the user of the MEDICAL SCALE MS5710 should assure that it is used in such an environment.

<b>Emission test</b>	<b>Compliance</b>	<b>Electromagnetic environment-guidance</b>
RF emissions CISPR 11	Group 1	The MEDICAL SCALE MS5710 uses RF energy only for its internal function. Therefore, its RF emissions are very low and are not likely to cause any interference in nearby electronic equipment.
RF emissions CISPR 11	Class B	The MEDICAL SCALE MS5710 is suitable for use in all establishments, including domestic establishments and those directly connected to the public low-voltage power supply network that supplies buildings used for domestic purposes.
Harmonic emissions IEC 61000-3-2	Class A	
Voltage fluctuations /flicker emissions IEC 61000-3-3	Compliance	

### Guidance and manufacturer's declaration-electromagnetic immunity

The MEDICAL SCALE MS5710 is intended for use in the electromagnetic environment specified below.

The customer or the user of the MEDICAL SCALE MS5710 should assure that it is used in such an environment.

<b>Immunity test</b>	<b>IEC 60601 test level</b>	<b>Compliance level</b>	<b>Electromagnetic environment-guidance</b>
Electrostatic discharge(ESD) IEC 61000-4-2	± 6 kV contact ± 8 kV air	± 6 kV contact ± 8 kV air	Floors should be wood, concrete or ceramic tile. If floors are covered with synthetic material, the relative humidity should be at least 30%
Electrical fast transient/burst IEC 61000-4-4	± 2kV for power supply lines + 1kV for input/output lines	± 2kV for power supply lines Not applicable	Mains power quality should be that of a typical commercial or hospital environment.
Surge IEC 61000-4-5	± 1kV line(s) to line(s) ± 2kV line(s) to earth	± 1kV differential mode Not applicable	Mains power quality should be that of a typical commercial or hospital environment.
Voltage Dips, short interruptions and voltage variations on power supply input lines IEC 61000-4-11	<5% UT(>95% dip in UT) for 0,5 cycle 40% UT(60% dip in UT) for 5 cycles 70% UT(30% dip in UT) for 25 cycles <5% UT(>95% dip in UT) for 5 s	<5% UT(>95% dip in UT) for 0,5 cycle 40% UT(60% dip in UT) for 5 cycles 70% UT(30% dip in UT) for 25 cycles <5% UT(>95% dip in UT) for 5 s	Mains power quality should be that of a typical commercial or hospital environment. If the user of the MEDICAL SCALE MS5710 requires continued operation during power mains interruptions, it is recommended that the MEDICAL SCALE MS5710 be powered from an uninterruptible power supply or a battery.

Power frequency(50/60 Hz) magnetic field IEC 61000-4-8	3 A/m	3 A/m	The MEDICAL SCALE MS5710 power frequency magnetic fields should be at levels characteristic of a typical location in a typical commercial or hospital environment.
NOTE UT is the a.c. mains voltage prior to application of the test level.			

<b>Guidance and manufacturer's declaration-electromagnetic immunity</b>			
The MEDICAL SCALE MS5710 is intended for use in the electromagnetic environment specified below. The customer or the user of the MEDICAL SCALE MS5710 should assure that is used in such and environment.			
<b>Immunity test</b>	<b>IEC 60601 test level</b>	<b>Compliance level</b>	<b>Electromagnetic environment-guidance</b>
Conducted RF IEC 61000-4-6	3 Vrms 150 KHz to 80 MHz	3 Vrms	<p>Portable and mobile RF communications equipment should be used no closer to any part of the MEDICAL SCALE MS5710 including cables, than the recommended separation distance calculated from the equation applicable to the frequency of the transmitter.</p> <p><b>Recommended separation distance:</b>  <math>d = 1,2 \sqrt{P}</math>  <math>d = 1,2 \sqrt{P}</math> 80MHz to 800 MHz  <math>d = 2,3 \sqrt{P}</math> 800MHz to 2,5 GHz</p> <p>Where <math>P</math> is the maximum output power rating of the transmitter in watts (W) according to the transmitter manufacturer and <math>d</math> is the recommended separation distance in metres (m).</p>

<p>Radiated RF IEC 61000-4-3</p>	<p>3 V/m 80MHz to 2,5 GHz</p>	<p>3 V/m</p>	<p>Field strengths from fixed RF transmitters, as determined by an electromagnetic site survey<sup>a</sup>, should be less than the compliance level in each frequency range<sup>b</sup>.</p> <p>Interference may occur in the vicinity of equipment marked with the following symbol:</p> 
<p>NOTE1 At 80 MHz and 800 MHz, the higher frequency range applies. NOTE2 These guidelines may not apply in all situations. Electromagnetic propagation is affected by absorption and reflection from structures, objects and people.</p>			
<p>a Field strengths from fixed transmitters, such as base stations for radio (cellular/cordless) telephones and land mobile radios, amateur radio, AM and FM radio broadcast and TV broadcast cannot be predicted theoretically with accuracy. To assess the electromagnetic environment due to fixed RF transmitters, an electromagnetic site survey should be considered. If the measured field strength in the location in which the MEDICAL SCALE MS5710 is used exceeds the applicable RF compliance level above, the MEDICAL SCALE MS5710 should be observed to verify normal operation. If abnormal performance is observed, additional measures may be necessary, such as re-orienting or relocating the MEDICAL SCALE MS5710.</p> <p>b Over the frequency range 150 kHz to 80 MHz, field strengths should be less than 3 V/m.</p>			

## Recommended separation distance between portable and mobile RF communications equipment and the MEDICAL SCALE

The MEDICAL SCALE MS5710 is intended for use in an electromagnetic environment in which radiated RF disturbances are controlled. The customer or the user of the MEDICAL SCALE MS5710 can help prevent electromagnetic interference by maintaining a minimum distance between portable and mobile RF communications equipment (transmitters) and the MEDICAL SCALE MS5710 as recommended below, according to the maximum output power of the communications equipment.

Rated maximum output power of transmitter  W	Separation distance according to frequency of transmitter m		
	150 kHz to 80 MHz  $d = 1,2\sqrt{P}$	80 MHz to 800 MHz  $d = 1,2\sqrt{P}$	800 MHz to 2,5 GHz  $d = 2,3\sqrt{P}$
0,01	0,12	0,12	0,23
0,1	0,38	0,38	0,73
1	1,2	1,2	2,3
10	3,8	3,8	7,3
100	12	12	23

For transmitters rated at a maximum output power not listed above, the recommended separation distance  $d$  in metres (m) can be estimated using the equation applicable to the frequency of the transmitter, where  $p$  is the maximum output power rating of the transmitter in watts (W) according to the transmitter manufacturer.

NOTE1 At 80 MHz and 800 MHz, the separation distance for the higher frequency range applies.

NOTE2 These guidelines may not apply in all situations. Electromagnetic propagation is affected by absorption and reflection from structures, objects and people.

## SPECIFICATION

<b>Model</b>	<b>MS 5710</b>	<b>MS 5711 / MS5712</b>
<b>Capacity</b>	<b>300kg x 0.1kg OIML CLASS III</b>	<b>300kg x 0.1kg</b>
<b>Accuracy</b>	$\pm 150\text{g}$	$\pm 200\text{g}$
<b>Weight Unit</b>	kg	kg/lb
<b>Certificate</b>	Medical device/ Class III	<b>CE</b>
<b>LCD Display</b>	1.0 inch LCD display with 5 and 1/2 digits	
<b>Dimension</b>	<b>360*410*120mm</b>	
<b>Key Functions</b>	ON/OFF ,  (zero), HOLD/BMI , TARE	ON/OFF , UNIT , HOLD/BMI , TARE
<b>Operating Temp. and humidity</b>	5°C - 35°C 15%-85% RH	
<b>Transport and storage temperature and humidity</b>	-20°C +60°C 10%-95% RH	
<b>Power supply</b>	Six 1.5V AAA size alkaline batteries	

Adaptor type: 12V



## PANEL

### MS 5710

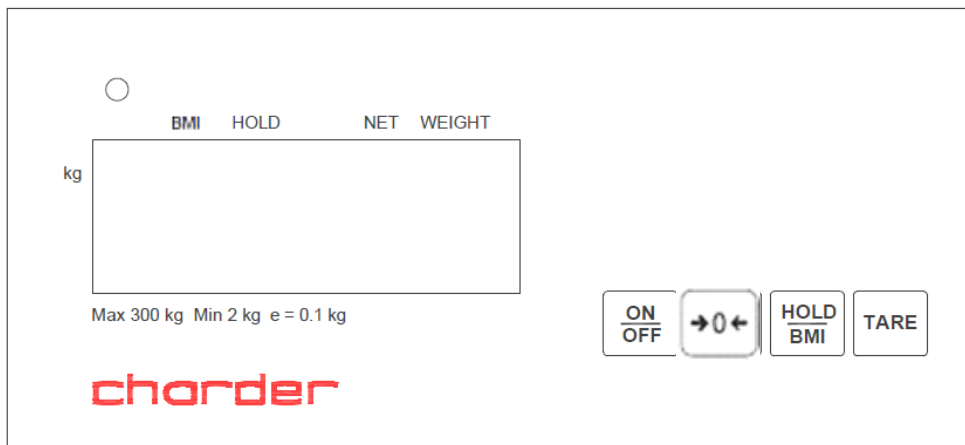

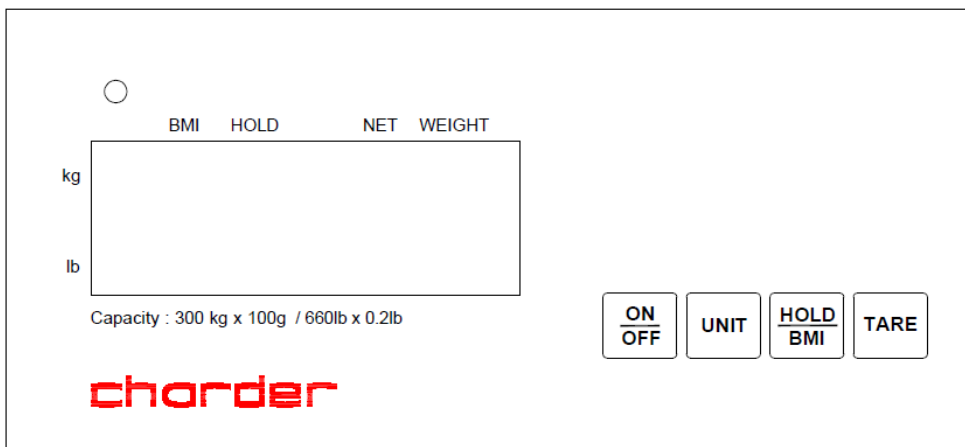

### MS 5711 / MS5712



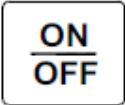
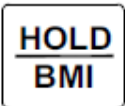
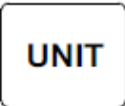

## KEY FUNCTION

### MS 5710 / 5711 / 5712

Key	Description
	Turn ON/OFF the scale
	Determine Body Mass Index , To hold weighing result on the display / determine stable weighing value
	Selecting measuring units between kg or lb.
	Tare weight during weighing process.
	To reset the display to 0.0kg display / Zero the scale ( $\pm 2\%$ of full capacity)

## POWER ADAPTOR STANDARDS

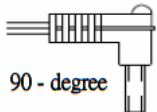
 **CAUTION:** The device is only compatible with restricted power adaptors in dashed block below.

AMP VOLTAGE	DRAWING NO.:	CE APPROVED TYPE NO. / MODEL NO.:	TYPE		
9V DC 100mA	AD-0484	D35W090100-23/1	US	 90 - degree	
9V DC 100mA	AD-038A	D41W1090100-13/1	EU		
9V DC 100mA	AD-037A	D41WK090100-23/2	UK		
9V 200mA	AD-8082(AD-0544)	UE05WCP-090020SPC	US		
9V 200mA	AD-8082(AD-0544)	UE05WCP-090020SPC	EU		
9V 200mA	AD-8082(AD-0544)	UE05WCP-090020SPC	UK		
9V 200mA	AD-8082A(AD-0544A)	UE05WCP-090020SPC	AU		
15V 300mA	AD-016D	D41W150300-13/1	US		
15V 300mA	AD-0420	D41WI150300-13/1	EU		
15V 300mA	AD-0370	D41WK150300-23/2	UK		
15V 300mA	AD-0482	D41WA150300-13/2	AU		
15V300mA	AD-8079D(AD-0536D)	UE05WCP-150030SPC	US		
15V300mA	AD-8079A(AD-0536A)	UE05WCP-150030SPC	EU		
15V300mA	AD-8079B(AD-0536B)	UE05WCP-150030SPC	UK		
15V300mA	AD-8079C(AD-0536C)	UE05WCP-150030SPC	AU		
12V 1A	AD-8084B	UE24WV-120100SPA	EU		 180 - degree
12V 1A	AD-8084	UE24WB-120100SPA	UK		
12V 1A	AD-8095	UE24WCP1-120100SPA	US		
12V 1A	AD-8095	UE24WCP1-120100SPA	EU		
12V 1A	AD-8095	UE24WCP1-120100SPA	UK		
12V 1A	AD-8095	UE24WCP1-120100SPA	AU		
12V 2A	AD-8058(AD-0521)	UE24WU-120200SPA	US		
12V 2A	AD-8057(AD-0520)	UE24WV-120200SPA	EU		
12V 2A	AD-8056(AD-0519)	UE24WB-120200SPA	UK		
12V 2A	AD-8074(AD-0534)	UE24W4-120200SPAS	AU		
12V 1A	AD-8096	UE24WCP1-120100SPA	US		
12V 1A	AD-8096	UE24WCP1-120100SPA	EU		
12V 1A	AD-8096	UE24WCP1-120100SPA	UK		
12V 1A	AD-8096	UE24WCP1-120100SPA	AU		
12A 1.5A	AD-8025A(AD-0527)	GFP181DA-120150B-2	US		
12A 1.5A	AD-8025D(AD-0529)	GFP181DA-120150B-2	UK		

## LCD DISPLAY SYMBOLS

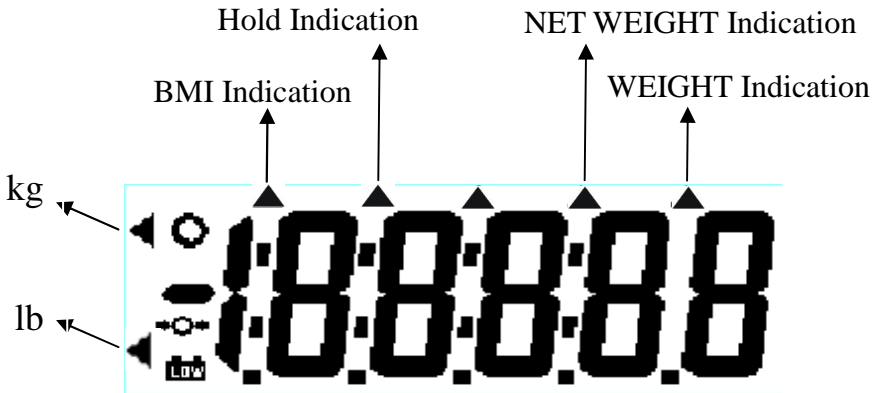

### Definitions

**Stable symbol:** To indicate that the weight is stable.

**Minor weight:** Weight under zero.

**Zero symbols:** Weight is at zero point.

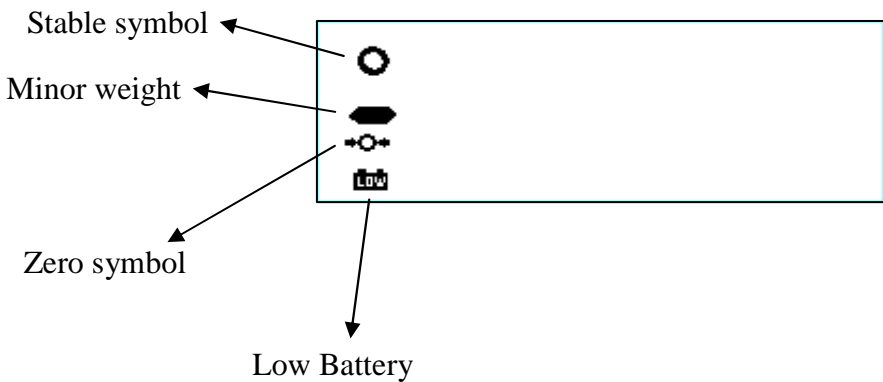

**Low battery:** Battery need to charge or replaced



## USING SCALE

### WEIGHING

- ◆ Switch on the scale using  key. The diagnostic scale self-check is performed and the software version is displayed.
- ◆ The „0,00 kg” weight displays on the screen, now the scale is ready for weighing.

*Note:* If „0,00 kg” won't display on the screen, press  key to zero the scale,  can be used any time to zero the scale.

- ◆ Place a person in the middle of the scale. Wait until the scale stabilizes and stable sign (o) shows on the screen

#### ***Direction:***





If a person is heavier than the scale capacity, the display will show the „Err” prompt (= overload).

## USING HOLD FUNCTION

MS 5710 and MS 5711 / MS5712 are provided with the integrated hold function (determination of average value). It enables people to be weighed accurately although they are not still on the scale plate.

Once the  key is pressed, the weight reading will remain on the display after the item has been removed from the scale so the reading can easily be read.

*Note:* Determination of average value is not possible when a person moves too much.

- Switch 'ON' the scale using  key. The diagnostic self-checks is performed. The scale is ready for weighing when the „**0.0 kg**” displays on the screen.
- Place object/ person in the center of the scale plate.
- Press the  key. When the triangle is flashing on the display, the scale records the fluctuating weight values and then calculates average weight and displays the result on the screen.
- Remove the object/ person from the scale platform. The object/ person's weight reading will remain on the display.
- Press the  key again to return the scale to the normal weighing mode.
- HOLD function can be activated before or after putting the weight on the tread platform. But in case of weighing unstable person it is recommended to press  key before the person moves on the tread platform.

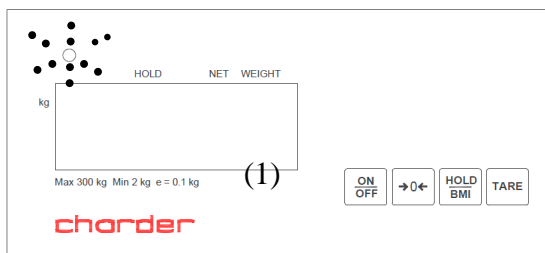

(2)

## USING TARE FUNCTION

Tare allows the user to zero the instrument to cancel the weight of a container/ clothes from the reading of the instrument, thus giving the true weight of the product/ person being tested.











- Place the object need to be tare on the tread platform.
- Press  key after the weight stabilizes and stable sign displays.
- Place the object need to be weighed (without removing the tare object)

To delete the saved tare value, remove the tare object from the tread platform and press  key.

## USING BMI FEATURE

For BMI calculation, height is needed, therefore it is recommended to measure the height of subject before starting weighing procedure and the height must be in centimeters.



### MS 5710/5711/5712

1. Turn on the scale using  key.
2. Proceed to weigh as normal.
3. After the weight is stable and stable sign displays on the screen long press  key for 3 seconds.
4. Display will change to  display.
5. Enter the height of the person using  and  key-  (For example: To enter 186cm, use  key to change the number and Use  key to move to next digit).
6. Press  or  key to confirm the height.



7. The B.M.I. will display 

8. Press  again to return to normal mode.

9. Use  or  to reset the display to 0.0kg/ Zero the scale

### Body Mass Index Categories

Classification of weight for adults over 18 years on the basis of Body Mass Index according to WHO, 2000 EK IV and WHO 2004 (WHO - World Health Organization).

Category	BMI (kg/m <sup>2</sup> )	Risk of diseases accompanying overweight
Underweight	< 18.5	low
Normal weight	18.5 – 24.9	average
Overweight	≥ 25.0	
Preobesity	25.0 – 29.9	slightly increased
I degree of obesity	30.0 – 34.9	increased
II degree of obesity	35.0 – 39.9	high
III degree of obesity	≥ 40	very high

### MS 5710/5711/5712: SET-UP

**MS 5710 / 5711 / 5712:** Switch ON the scale and long press



or  key for 3 seconds.

***First “SETUP” and then “A.OFF” will display successively.***

### AUTO-OFF TIME SETUP

This enables operator to select the auto turn OFF time of the device.

### BUZZER ON/OFF SETUP

This enables operator to select beep sound ON/OFF.

Auto off time: 120 sec/180 sec/240 sec/300 sec/off

Buzzer: On/Off

Press ZERO key  
3 seconds

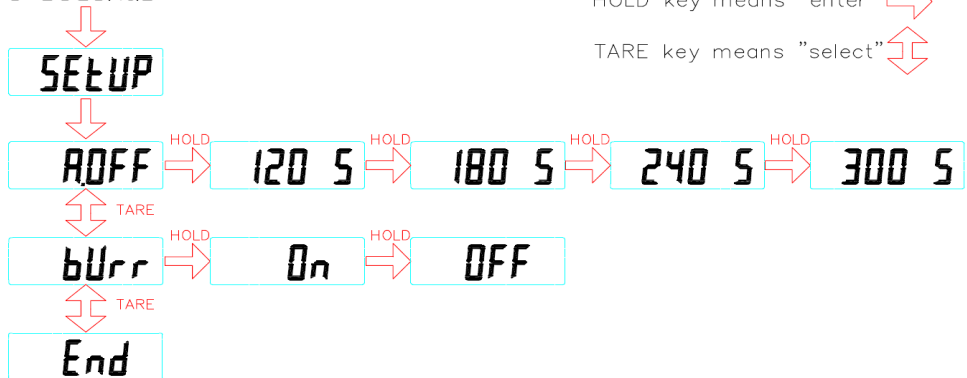

**Note:** To confirm the settings, please press  when **End** displays on the display.

## PRINT FUNCTION

The Weighing, BMI and Height results can be printed-out for records using RS232 interface cable (included in accessory kit), which is connected with the round plug at the back terminal.

The format presented below is the standard format of results print-out and cannot be changed.

GROSS WEIGHT	88,8 kg
TARE WEIGHT	2,0 kg
NET WEIGHT	86,8 kg
PATIENT HEIGHT	188,5 cm
PATIENT B.M.I	24,4

## RS232 Pin out

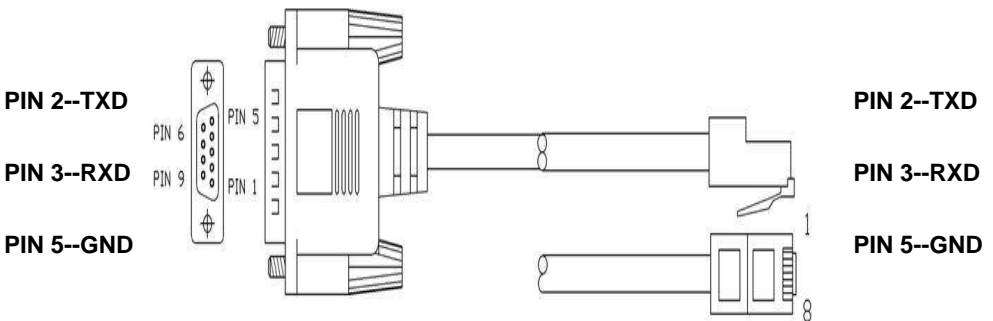
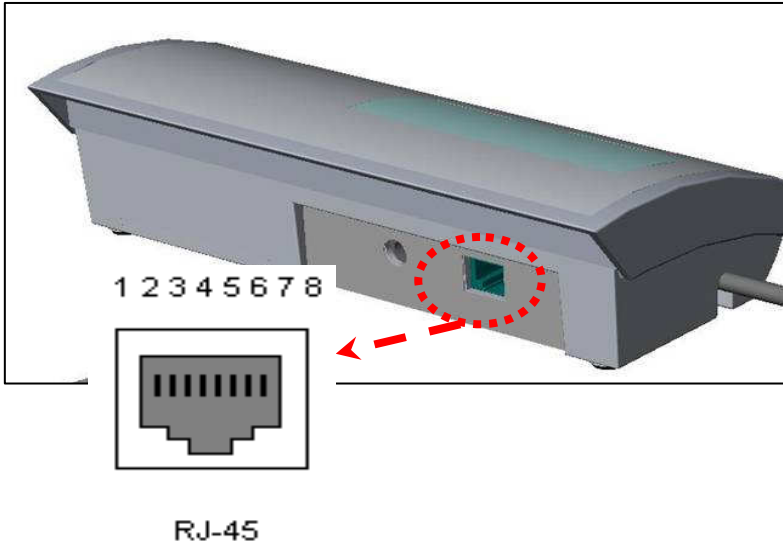

Connecting with PC- MS 5710/5711/5712 can be connected to PC to transfer the weighing results.

### 1. Start Hyper Terminal

Start Hyper Terminal program from clicking Start Menu → Programs → Accessories → Communication → Hyper Terminal.

## 2. New Connection Description

Give new connection a name then click OK.

## 3. Select Your COM Port

Click Connect to select your COM port. Usually there's only one option for select. Then click OK.

## 4. Port Settings

Click Bits per second to set up rate at 9600, Data bits at 8, Parity at None, Stop bits at 1 and Flow control at Hardware. Then click OK to complete your setting.











## 5. Output Data

When the patient has been weighed and BMI calculated, simply press the PRINT key to output data from scale to PC or an Optional Printer.

### Parameters of RS232 interface

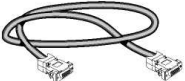
Set parameters of the scale interface on the connected device. It is not possible to change the scale parameters.

- Baud rate: 9600 bps
- Parity check: None
- Data length: 8 bits
- Stop bit: 1 bit
- Handshake: RTS/CTS
- Data code: ASCII.

No.	Accessories	Item	Spec.	Qty.
1		Adjustable feet	M6*15	2
2		Spacer	φ 6.6* φ 13	2
3		Fixed plate (top)	SS-4961	1
4		Fixed plate (bottom)	SS-4971	1
5		Tapping Screw	M3*10	3
6		User manual	IN-1159	1
7		RS232 cable	WR-2781	1
8		12V Adaptor		1
9		Plastic anchor	1"(white)	2
10		Screw	4*20	2

## INSTRUCTION FOR CHARGING AND CONNECTING

If **. Lo** prompt displays on the LCD, please charge the scale with MS 5710/5711/5712 exclusive adaptor or replace the batteries.

**Locate adaptor plug-in at the back side of indicator.**

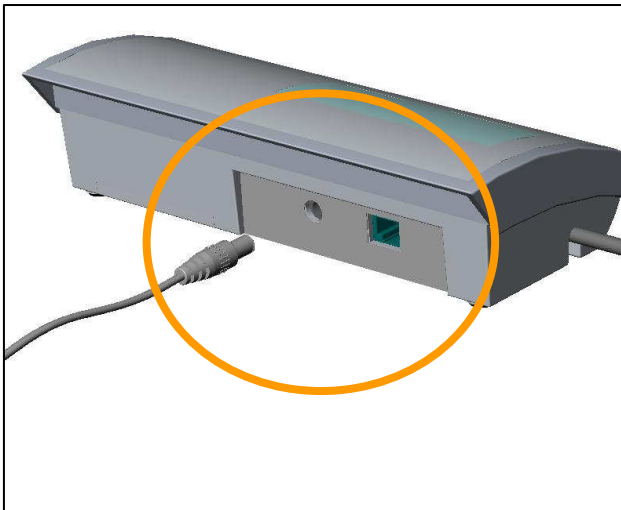

### **CAUTION:**

- Always connect the AC adaptor with the indicator before connecting to the mains power supply.
- Please disconnect the adaptor from main power supply before taking out the AC adaptor pin from indicator.

## INSTRUCTION FOR REPLACING BATTERIES



1. Removing the battery cover.



2. Take the battery housing out.

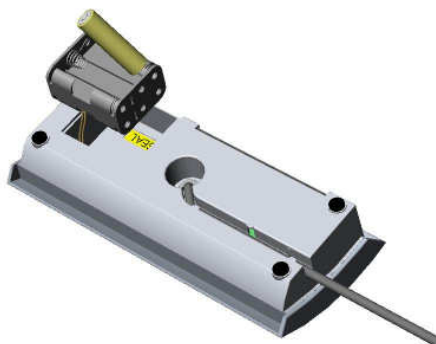

3. Replacing new batteries.

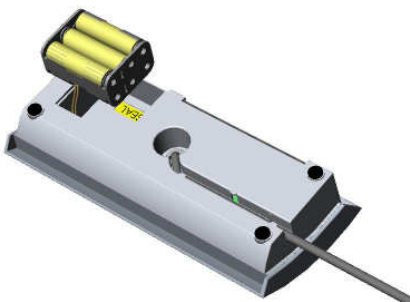

4. Batteries are well installed.









5. Installing the battery housing.



6. Reinstalling the battery cover.



## ERROR MESSAGE

ERROR MESSAGE	REASON	ACTION
	Low Battery: This warning shows that the voltage of battery is too low to use.	Please replace a new battery or plug the AC adaptor for operation.
	Overload: The total load exceeds the maximum capacity of scale.	Please reduce the loading and try again.
	Counting error(too high): Indicates that the signal from the loadcell is too high.	This error is normally caused by a serious fault on the scales such as a faulty loadcell or wiring. Please contact the local service representatives.
	Counting error(too low): Indicates that the signal from the loadcell is too low.	This error is normally caused by a serious fault on the scales such as a faulty loadcell or wiring. Please contact the local service representatives.
	Zero count over calibration zero range +10% while power on.	Please re-calibrate the instrument.
	Zero count under calibration zero range -10% while power on.	Please re-calibrate the instrument.
	EEPROM Error: Indicates that there is a fault with the scales software.	This error is normally caused by a serious fault on the scales such as a faulty loadcell or wiring. Please contact the loadcell service representatives.

## **TROUBLESHOOTING**

### **Troubleshooting for defective modes:**

Original purchaser can enjoy the benefits under the effective Warranty against functional defects in material and workmanship subject to the terms and conditions listed in the yearly Warranty Program & Return Policy.

Our warranty service program includes the following:

1. Technician repair service under warranty or at a service maintenance charge depending on the workmanship for the defective functionality or cause of damage covered by the warranty.
2. Parts replacement from the manufacturing factory under the warranty or at a certain cost for the replaced parts plus the workmanship charge if not covered under the warranty.

Before you contact our Authorized Dealer in your country for technician repair service, please read through the following section carefully:

### **Self-checking Tips:**

Some functional defects can be identified and maintained by users as listed below:

#### **1. Power-on failure**

- Check if the main power adaptor has not plugged onto the scale properly
- Check if the battery power is running low - Replace with new batteries

## **2. Indicator showing “0000” ZERO SPAN out of range**

- Incorrect weighing result - Avoid damages by external environment force such as free-drop to the ground, collision by external objects, etc.
- Proper re-calibration procedure required to correct the setting of weighing accuracy.
- Interference due to RF disturbance, ground vibration...etc.
- Unstable platform feet adjustments according to bubble level indication
- Incorrect position or other external objects within weighing area
- The weighing-scale is not put in a solid & firm ground area, such as carpet floor or lawn.

## **3. Connection failure for data transmission to PC or printer**

- Wrong connection wires or faulty wires for transmission between the digital indicator & load cells.
- Wrong indicator models
- Wrong internal wiring or wire broken

**In case of the following defective mode occurs, it is suggested to contact your nearest Authorized Dealer for further technician service & repair:**

### **1. POWER switch-on failure :**

- Push-button faulty
- Short circuit wires - Wire broken
- Safety fuse burnt out
- Wire connection problem
- Main power adaptor faulty – Parts Replacement

---

## 2. LCD display faulty

- Possible hardware defects include: Uneven brightness in the LCD display screen & texts color blurred, smeared rainbow screen, incorrect decimal display
- LCD PIN broken or short circuit
- PCB cooper foil broken & loosed welding
- Unable to save or read data – IC or transistor faulty, internal parts broken.
- LCD showing “ERRL” after switch on - Load cell damaged
- Overload may cause the weigh to malfunction.
- Software system crash
- Resonator faulty
- Load cells with faulty grinding standard.
- Key buttons failure - Front key panel damaged or disconnected

## 3. Buzzer malfunction

- Wrong welding of PVC wire
- Key buttons & control panel damaged or disconnected.



## Declaration of Conformity

The Non-Automatic Weighing Instrument

III

Manufacturer	Charder Electronic Co., Ltd
Model	MS-5710
EC Type Approval Certificate No.	T7105

The Metrological Aspects of Non-Automatic Weighing Instruments

EN45501:2015 (module D)	Notified Body Number – 0126
EN45501:1992 (module B)	Notified Body Number – 0122

The non-automatic weighing instrument corresponds to the production model described in the EC Type Approval Certificate and requirements of the following EC Directives:

2014/31/EU	Non-Automatic Weighing Instruments Directive
93/42/EEC as amended by 2007/47/EC	Medical Device Directive

The applicable harmonized standards are:

EN45501:2015	The Metrological Aspects of Non-Automatic Weighing Machines
EN ISO14971:2012	Medical devices - Application of risk management to medical devices
EN ISO10993-1:2009	Biological evaluation of medical devices - Part 1: Evaluation and testing within a risk management process
EN60601-1:2006	Medical electrical equipment - Part 1: General requirements for basic safety and essential performance
EN60601-1-2:2007	Medical electrical equipment - Part 1-2: General requirements for basic safety and essential performance – Collateral standard: Electromagnetic compatibility - Requirements and tests
EN60601-1-6:2010	Medical electrical equipment - Part 1-6: General requirements for basic safety and essential performance - Collateral standard: Usability
EN62304:2006	Medical device software - Software life-cycle processes
EN980:2008	Symbols for use in the labelling of medical devices

This declaration of conformity is issued under the sole responsibility of the manufacturer.

Date: May, 5<sup>th</sup> 2017

Signature: \_\_\_\_\_

Name: Angela Lu  
Position: Measuring Management Rep.  
Place: Taichung, Taiwan



Manufacturer: Charder Electronic Co., Ltd.

Address: NO.103, Guozhong Rd., Dai Dist., Taichung City 412, Taiwan (R.O.C.)

T-152C

# Manufacturer's Declaration of Conformity

This product has been manufactured in accordance with the harmonized European standards, following the provisions of the below stated directives:

	93/42/EEC as amended by 2007/47/EC Medical Device Directive
	2014/31/EU Non-automatic Weighing Instruments Directive

*Please see separate document showing on sticker of device for above CE marking.*

## Authorized EU Representative:



**Wellkang Ltd**  
Suite B, 29 Harley Street  
LONDON, W1G 9QR, U.K.

Manufactured by:



**Charder Electronic Co., Ltd.**  
No.103, Guozhong Rd., Dali Dist.,  
Taichung City 412 ,Taiwan (R.O.C.)

FDA no.: D051882 (for model MS5710. MS5711)

IN-1159 [10126M] 05/2017