



Wheel chair Scale

USER MANUAL

MS3880















Please keep the instruction manual at hand and follow instruction for use.

CONTENTS

I. Explanation of Graphic Symbols on Label/Packaging	3
II. Copyright Notice	5
III. Safety Notes	6
A. General Information	6
B. EMC Guidance and Manufacturer's Declaration	10
IV. Handrail Installation (optional)	14
A. Handrail Parts.....	14
B. Handrail Assembly (optional)	17
C. Display Assembly	20
D. Foldable Handrail Assembly (SM-00001)	22
V. Powering device	23
A. Using adapter and charging battery.....	23
B. Replacing Rechargeable Battery Pack.....	23
VI. Indicator	25
A. Indicator and Key Functions	25
B. Display layout.....	26
VII. Basic Operation	27
A. Setup wireless data transfer	27
B. Pre-Tare.....	28
C. Weight measurement	31
D. BMI calculation	31
VIII. Device Setup	32
IX. Connecting scale to receiving device	34
X. Troubleshooting	35
XI. Product Specifications	37
XII. Declaration of Conformity	40

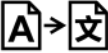
I. Explanation of Graphic Symbols on Label/Packaging

Text/Symbol	Meaning
	Caution. Failure to follow instructions may result in adverse events
	Separate collection for waste of electrical and electronic equipment, in accordance with Directive 2002/96/EC. Do not dispose of device with everyday waste
	Name and address of device manufacturer
	Carefully read user manual before installation and usage, and follow instructions for use.
	Medical electrical device, Type B applied part
REF	Device catalogue number
EU REP	Name and address of authorized representative in the European Union (applicable for medical devices only)
MD	Device is a medical device. Text indicates device category type
LOT	Manufacturer's batch or lot number for device
SN	Device's serial number
#	Device's model number
UDI	Device's Unique Device Identifier (01) GTIN (11) Production date (21) Serial number
e	Value in mass units. This is the difference between two consecutive display values, used to classify and verify a scale
CE 2460	Device conforms to (EU) 2017/745 Regulation on Medical Devices. Four digit number is identifier for medical device Notified Body
CE	Device claims conformity with essential regulations set by the relevant European Union legislation

	<p>Device complies with EU directives M: Conformity label in compliance with Directive 2014/31/EU for non-automatic weighing instruments 17: Year in which conformity verification was performed and the CE label was applied. (ex: 17=2017) 0122: Identifier for metrology Notified Body</p>
	<p>Device is a Class III scale in compliance with Directive 2014/31/EU</p>
	<p>Name and address of entity importing device</p>
	<p>Name and address of entity responsible for translating Information For Use</p>
<p>CON.</p>	<p>Event counter recording how many times protected-mode parameter adjustments relating to metrology-related characteristics (ex: gravity value) have been conducted for device</p>
	<p>Device has received Taiwan NCC approval</p>
	<p>Device conforms to U.S. Federal Communications Commission regulations</p>
	<p>Device complies with all UK applicable product legislation</p>
	<p>Device's polarity of power</p>

In case of differences, icon on device itself takes precedence.

II. Copyright Notice

Copyright Notice Charder Electronic Co., Ltd.

No.103, Guozhong Rd., Dali Dist., Taichung City 41262 Taiwan

Tel: +886-4-2406 3766

Fax: +886-4-2406 5612

Website: www.chardermedical.com E-mail: info_cec@charder.com.tw

Copyright© Charder Electronic Co., Ltd. All rights reserved.

This user manual is protected by international copyright law. All content is licensed, and usage is subject to written authorization from Charder Electronic Co., Ltd. (hereinafter Charder) Charder is not liable for any damage caused by a failure to adhere to requirements stated in this manual. Charder reserves the right to correct misprints in the manual without prior notice, and modify the exterior of the device for quality purposes without customer consent.



Charder Electronic Co., Ltd.
No. 103, Guozhong Rd., Dali Dist.,
Taichung City, 41262 Taiwan

III. Safety Notes

A. General Information

Thank you for choosing this Charder Medical device. It is designed to be easy and straightforward to operate, but if you encounter any problems not addressed in this manual, please contact your local Charder service partner.

Before beginning operation of the device, please read this user manual carefully, and keep it in a safe place for reference. It contains important instructions regarding installation, proper usage, and maintenance.

Intended Purpose

This medical device is designed to be used in accordance with national regulations, to measure weight within specifications, for weight-related usage by professionals.

Patient sitting on wheelchair is pushed onto measurement platform containing digital scale. Device measures weight of wheelchair plus patient using digital scale. By deducting weight of wheelchair from total, weight of patient can be measured.

Clinical Benefit

Measurement results can be used by professionals to diagnose (and monitor) weight-related issues.

Intended medical indications/contraindications

Measurement: subject's body weight. No known contraindications to measurement of body weight.

Intended patient profile

- (a) Age: no restrictions
- (b) Weight: no restrictions within device weight capacity (Patient's weight limit is dependent upon wheelchair weight. If wheelchair weighs 20 kg, patients up to 280 kg can be weighed if total capacity of device is 300 kg.)
- (c) Patient Conditions: require measurement of body weight.

Intended user profile

- (a) At least 20 years old

- (b) Minimum knowledge:
 - To be able to read at a high-school level and understand Arabic numerals (e.g. 1, 2, 3, 4...)
 - Basic hygiene knowledge
 - Trained in device's operation
 - Read the instruction manual
- (c) Language
 - Able to read the language of instruction manual and on-screen instructions
- (d) Qualifications
 - No special certifications or qualifications required
 - Able to push wheelchair onto measurement platform.

Residual Risk Evaluation

- (a) All foreseeable risks have been evaluated and considered acceptable. Generally speaking, the most likely risk caused by incorrect usage of the device is less accurate measurement (or inability to use device to acquire measurement), which does not pose imminent physical risk to patient or user.
- (b) Benefit-risk ratio is considered acceptable. Wheel chair scales are an important option for measuring patients. Usage of device is unlikely to result in harm to user or patient.

General Handling

- Device should be placed on stable, flat, solid, non-slippery surface.
- Usage on soft surfaces (ex: carpet) may result in inaccurate results.
- Ensure all parts are properly locked and tightened before operating the device.
- Device is intended to measure one subject at a time.

Safety Instructions

- Batteries should be kept away from children. If swallowed, promptly seek medical assistance.
- The device has an expected service life of 5 years when correctly handled, serviced, and periodically inspected in accordance with manufacturer's instructions
- Always comply with appropriate regulations when using electrical components under increased safety requirements.
- Ensure voltage marked on power supply matches mains power supply.
- The device is intended for indoor use only.
- Observe permissible ambient temperatures for use

Environmental

- All batteries contain toxic compounds; batteries should be disposed of via designated competent organizations. Batteries should not be incinerated.

Cleaning

- Device surface should be cleaned using alcohol-based wipes. Corrosive cleansing liquids should not be used. Pressure-washers should not be used.
- Do not use large amounts of water when cleaning the device, as it may cause damage to the internal electronics.
- Always disconnect device from mains power before cleaning.

Maintenance

- Please contact your local Charder distributor for regular maintenance and calibration, regular checking of accuracy is recommended; frequency to be determined by level of use and state of device.

Warranty/Liability

- The period of warranty shall be eighteen (18) months, beginning on the date of purchase. Please retain your receipt as proof of purchase.
- No responsibility shall be accepted for damage caused through any of the following reasons: unsuitable or improper storage or use, incorrect installation or commissioning by the owner or third parties, natural wear and tear, changes or modifications, incorrect or negligent handling, chemical, electrochemical, or electrical interference.
- All maintenance, technical inspections, and repairs should be conducted by an authorized Charder service partner, using original Charder accessories and spare parts. Charder is not liable for any damages arising from improper maintenance or usage.

Disposal

- This product is not to be treated as regular household waste, but should be taken to a designated collection points for electronics. Further information should be provided by local waste disposal authorities.



Warning

- Only the original adapter should be used with the device. Using an adapter other than the one provided by Charder may cause malfunction.
- Do not touch the power supply with wet hands.
- Do not crimp the power cable, and avoid sharp edges.
- Do not overload extension cables connected to the device.
- Route cables carefully, to avoid tripping.
- Keep device away from liquids.
- Do not remove the plug by yanking on the cable.
- Use only a correctly wired (100-240VAC) outlet, and do not use a multiple outlet extension cable.
- Do not under any circumstances dismantle or alter the device, as this could result in electric shock or injury as well as adversely affect the precision of measurements.
- Do not place the device in direct sunlight, or in close proximity to an intense heat source. Excessively high temperatures may damage the internal electronics.

Incident Reporting

- Any serious incident that has occurred in relation to the device should be reported to the manufacturer, EU representative (if device is used in EU member state), and competent authority of user/subject's member state.

B. EMC Guidance and Manufacturer's Declaration

Guidance and manufacturer's declaration-electromagnetic emissions		
<p>The product is intended for use in the electromagnetic environment specified below. The customer or the user of the product should assure that it is used in such an environment.</p>		
Emission test	Compliance	Electromagnetic environment-guidance
RF emissions CISPR 11	Group 1	The product uses RF energy only for its internal function. Therefore, its RF emissions are very low and are not likely to cause any interference in nearby electronic equipment.
RF emissions CISPR 11	Class A	The product is suitable for use in all establishments other than domestic and those directly connected to a low voltage power supply network which supplies buildings used for domestic purposes.
Harmonic emissions IEC 61000-3-2	Class A	
Voltage fluctuations /flicker emissions IEC 61000-3-3	Compliance	

Guidance and manufacturer's declaration-electromagnetic immunity

The product is intended for use in the electromagnetic environment specified below. The customer or the user of the product should assure that it is used in such an environment.

Immunity test	IEC 60601 test level	Compliance level	Electromagnetic environment-guidance
Electrostatic discharge(ESD) IEC 61000-4-2	±8 kV contact ±2 kV, ±4 kV, ±8 kV, ±15 kV air	±8 kV contact ±2 kV, ±4 kV, ± 8 kV, ±15 kV air	Floors should be wood, concrete or ceramic tile. If floors are covered with synthetic material, the relative humidity should be at least 30%
Electrical fast transient/burst IEC 61000-4-4	± 2kV for power supply lines	± 2kV for power supply lines	Mains power quality should be that of a typical commercial or hospital environment.
Surge IEC 61000-4-5	± 1kV line(s) to line(s) ± 2kV line(s) to earth	± 1kV line(s) to line(s) ± 2kV line(s) to earth	Mains power quality should be that of a typical commercial or hospital environment.
Voltage Dips, short interruptions and voltage variations on power supply input lines IEC 61000-4-11	0% UT for 0,5 cycle 0% UT for 1 cycle 70% UT(30% dip in UT) for 25cycles 0% UT for 5 s	0% UT for 0,5 cycle 0% UT for 1 cycle 70% UT(30% dip in UT) for 25cycles 0% UT for 5 s	Mains power quality should be that of a typical commercial or hospital environment. If the user of the product requires continued operation during power mains interruptions, it is recommended that the product be powered from an uninterruptible power supply or a battery.
Power frequency(50, 60 Hz) magnetic field IEC 61000-4-8	30 A/m	30 A/m	The product power frequency magnetic fields should be at levels characteristic of a typical location in a typical commercial or hospital environment.

NOTE UT is the a.c. mains voltage prior to application of the test level.

Guidance and manufacturer's declaration-electromagnetic immunity

The product is intended for use in the electromagnetic environment specified below.

The customer or the user of the product should assure that is used in such and environment.

Immunity test	IEC 60601 test level	Compliance level	Electromagnetic environment-guidance
Conducted RF IEC 61000-4-6	3 Vrms 150 KHz to 80 MHz 6 V in ISM bands between 0,15 MHz and 80 MHz 80 % AM at 1 kHz	3 Vrms 150 KHz to 80 MHz 6 V in ISM bands between 0,15 MHz and 80 MHz 80 % AM at 1 kHz	Portable and mobile RF communications equipment should be used no closer to any part of the product including cables, than the recommended separation distance calculated from the equation applicable to the frequency of the transmitter.
Radiated RF IEC 61000-4-3	3 V/m 80MHz to 2,7 GHz	3 V/m 80MHz to 2,7 GHz	Recommended separation distance: $d = 1,2 \sqrt{P}$ $d = 1,2 \sqrt{P}$ 80MHz to 800 MHz $d = 2,3 \sqrt{P}$ 800MHz to 2,7GHz Where P is the maximum output power rating of the transmitter in watts (W) according to the transmitter manufacturer and d is the recommended separation distance in meters (m).
			Field strengths from fixed RF transmitters, as determined by an electromagnetic site survey, ^a should be less than the compliance level in each frequency range. ^b
			Interference may occur in the vicinity of equipment marked with the following symbol:
			

NOTE1 At 80 MHz and 800 MHz, the higher frequency range applies.

NOTE2 These guidelines may not apply in all situations. Electromagnetic propagation is affected by absorption and reflection from structures, objects and people.

a Field strengths from fixed transmitters, such as base stations for radio (cellular/cordless) telephones and land mobile radios, amateur radio, AM and FM radio broadcast and TV broadcast cannot be predicted theoretically with accuracy. To assess the electromagnetic environment due to fixed RF transmitters, an electromagnetic site survey should be considered. If the measured field strength in the location in which the product is used exceeds the applicable RF compliance level above, the product should be observed to verify normal operation. If abnormal performance is observed, additional measures may be necessary, such as re-orienting or relocating the product.

b Over the frequency range 150 kHz to 80 MHz, field strengths should be less than 3V/m.

Recommended separation distance between portable and mobile RF communications equipment and the product

The product is intended for use in an electromagnetic environment in which radiated RF disturbances are controlled. The customer or the user of the product can help prevent electromagnetic interference by maintaining a minimum distance between portable and mobile RF communications equipment (transmitters) and the product as recommended below, according to the maximum output power of the communications equipment.

Rated maximum output power of transmitter W	Separation distance according to frequency of transmitter m		
	150 kHz to 80 MHz $d = 1,2\sqrt{P}$	80 MHz to 800 MHz $d = 1,2\sqrt{P}$	800 MHz to 2,7 GHz $d = 2,3\sqrt{P}$
0,01	0,12	0,12	0,23
0,1	0,38	0,38	0,73
1	1,2	1,2	2,3
10	3,8	3,8	7,3
100	12	12	23

For transmitters rated at a maximum output power not listed above, the recommended separation distance d in meters (m) can be estimated using the equation applicable to the frequency of the transmitter, where p is the maximum output power rating of the transmitter in watts (W) according to the transmitter manufacturer.

NOTE1 At 80 MHz and 800 MHz, the separation distance for the higher frequency range applies.



NOTE2 These guidelines may not apply in all situations. Electromagnetic propagation is affected by absorption and reflection from structures, objects and people.

IV. Handrail Installation (optional)

A. Handrail Parts

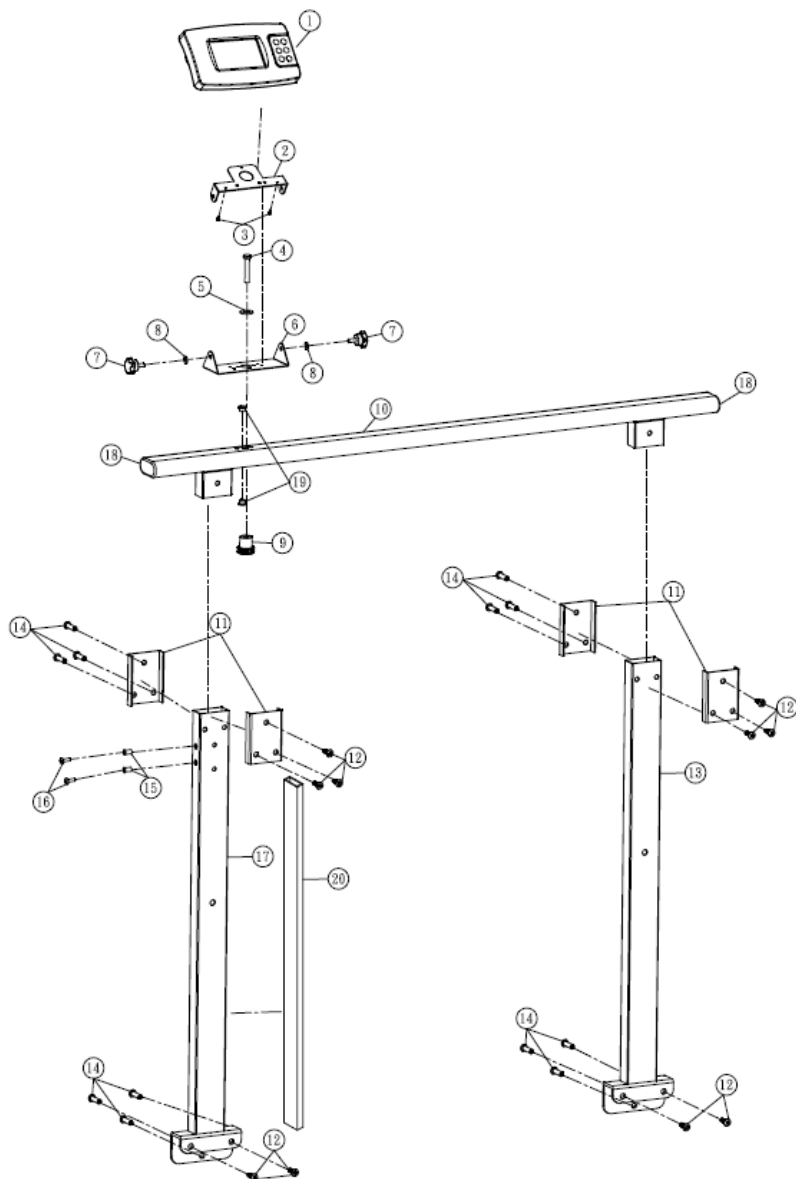

Parts List - Right Handrail (SM-3461)

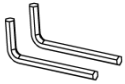

NO.	Part	Part No.	Qty.
1	Indicator	DP4800	1
2	Upper bracket	CD-SS-4961	1
3	Pan-head phillips screw	M3*8L	2
4	Hexagon Screw	M8*1.25*45L	1
5	Washer	M8 OD ø 22 T=2mm	1
6	Bottom bracket	CD-AM-00081	1
7	Adjustment knob	MP00600331	2
8	Washer	M6 OD ø 22 T=1mm	2
9	Adjustment knob	K300-21-M8	1
10	handrail bar without screw hole	SS-6753	1
11	Fixing plate	SS-6761	4
12	Socket button head cap screw	M6-21 	10
13	Pole	AM-1851	1
14	socket button head cap screw nut	ø8-M6*33 	12
15	Rivet Nut	M5-0.8-JB	2
16	Plastic screw	M5-0.8*8	2
17	Pole-A	AM-2271	1
18	Rubber end cap	SW-3071	2
19	Self-lubricating bearing	SF-1F-08075 	2
20	Wiring Duct	TC-2WE 100cm	1
21	Weighing platform	MS3800	1
22	socket key		2

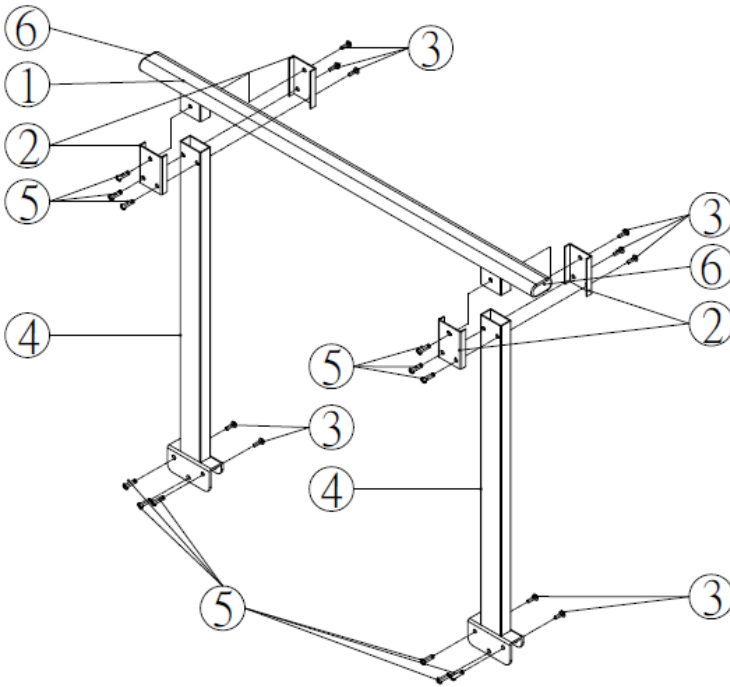
Parts List - Left Handrail (SM-3462)

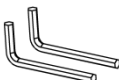

No.	Item	Drawing	Qty.
1.	handrail bar without screw hole	SS-8300A	1
2.	fixing plate	SS-8311	4
3.	socket button head cap screw	M6-21 	10
4.	pole	AM-8173	2
5.	socket button head cap screw nut	ø8-M6*33 	12
6.	rubber end cap	SW-8068	2
7.	socket key		2

B. Handrail Assembly (optional)

1. Attach No.2 (fixing plate) to No.9 (pole with wiring duct) using No.3 (socket screw) and No.5 (screw nut). Attach No.9 (pole with wiring duct) to platform using No.3 (socket screw) and No.5 (screw nut).

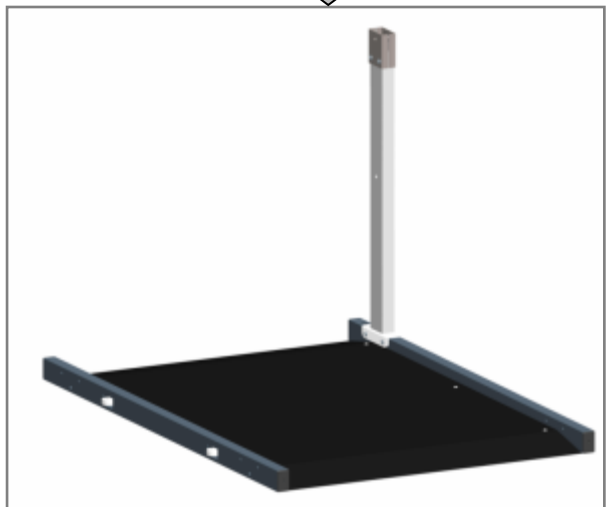
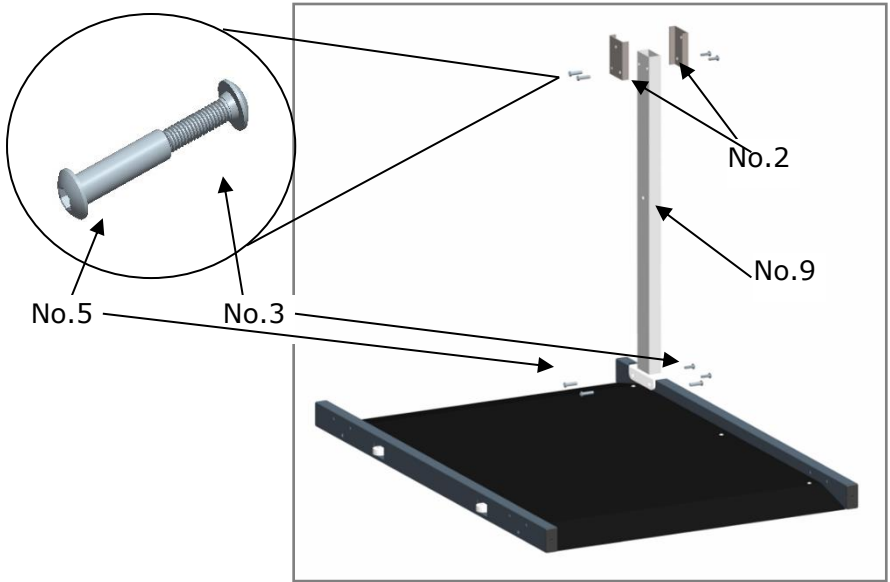

2. Assemble pole on platform using same procedure as Step 1.

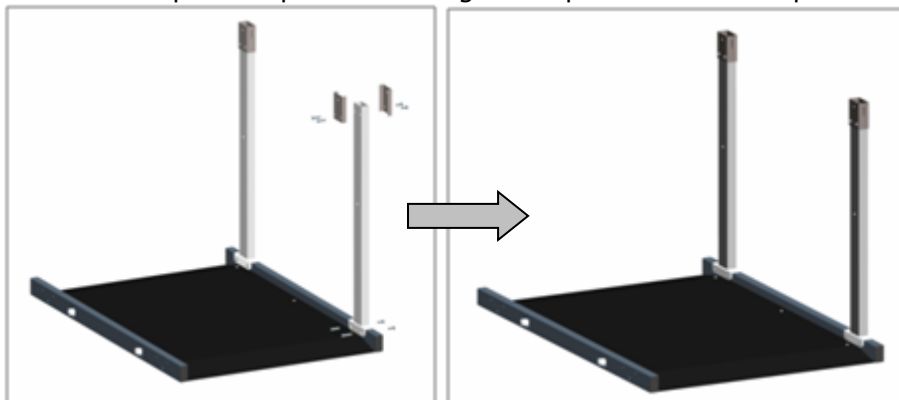

3. Attach handrail bar to poles using No. 5 and No. 3 screws.

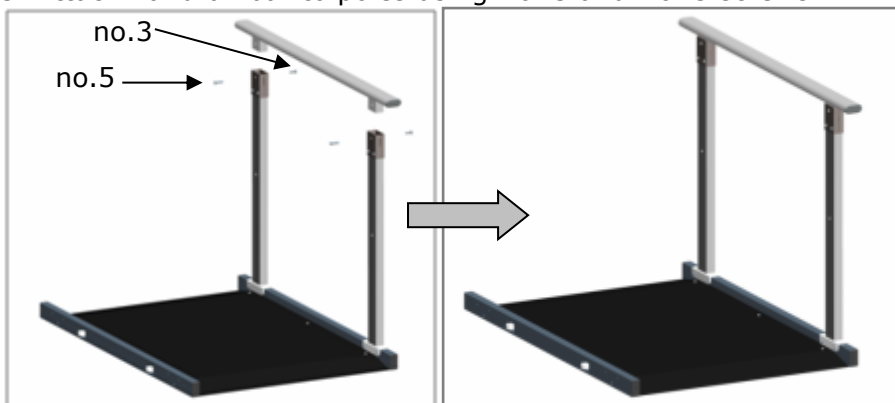

4. Attach third and fourth pole to platform.

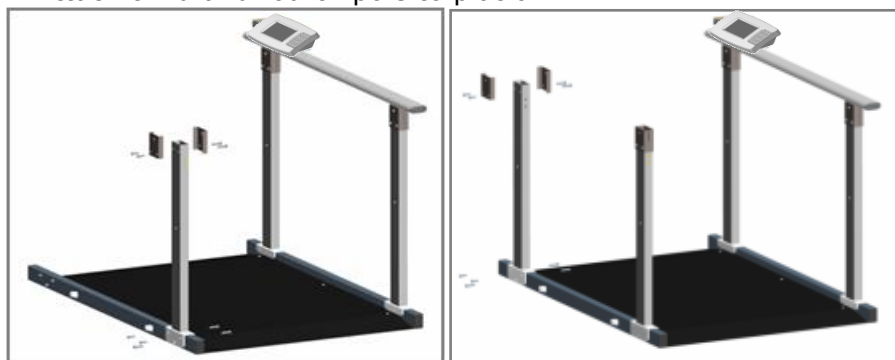

5. Assemble handrail bar

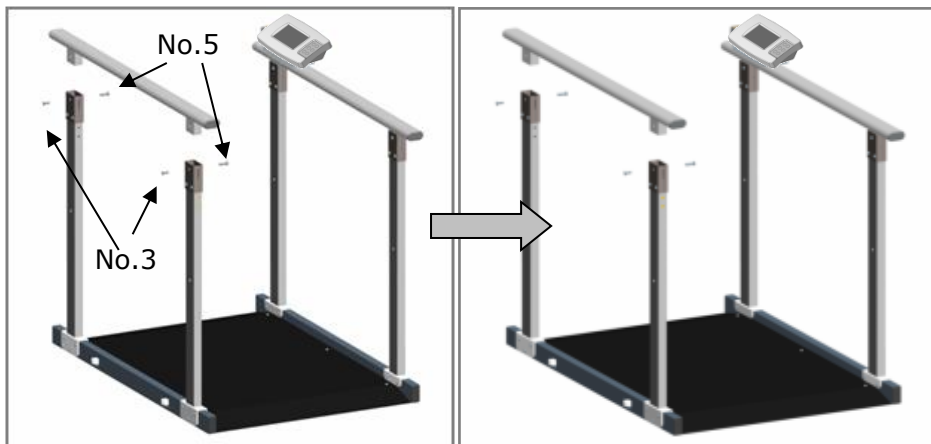

6. Attach cross bar (SS-8444) using No.11 screws (M8-1.25P*45).

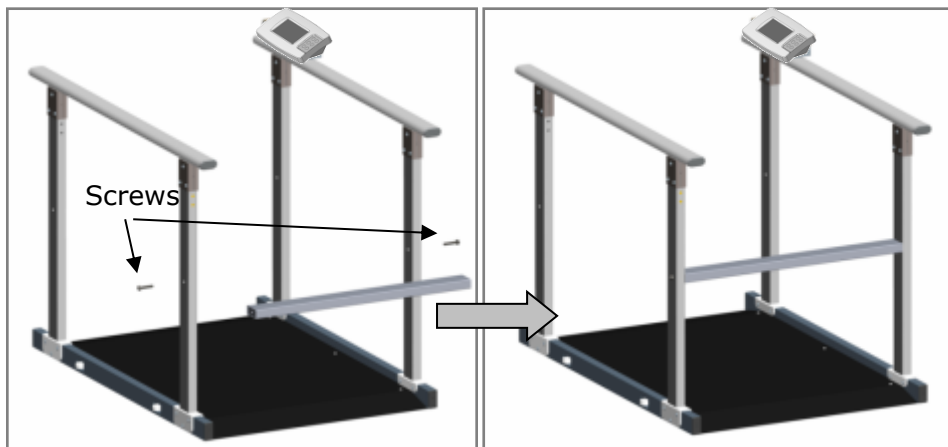

C. Display Assembly

First step: Assemble the upper set

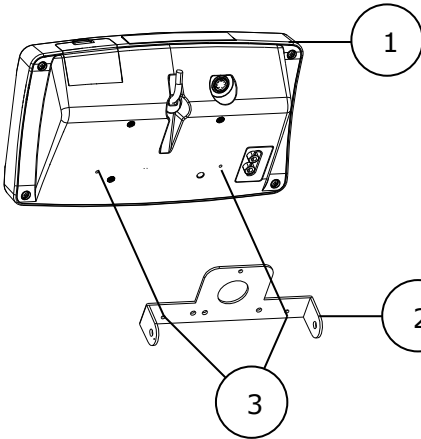

Please use 2 screws (3) to combine the indicator (1) with the fixing plate (2) to complete the upper set! Then please proceed the second step.

Second step : Assemble the lower set

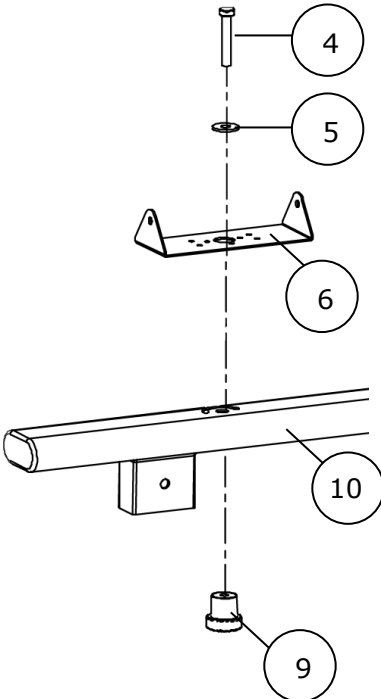

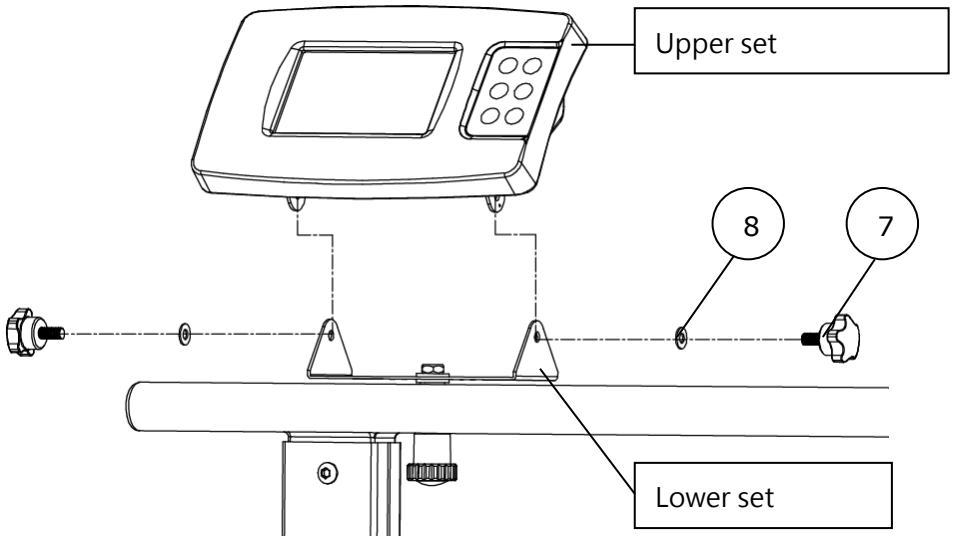

Please place the fixing plate (6) on the right handrail bar (10), and place the washer (5) and the screw (4) on the fixing plate (6), and use the adjustment knob (9) to rotate from bottom to top and fix it to complete the lower set.

Third step: Combine the upper and lower sets

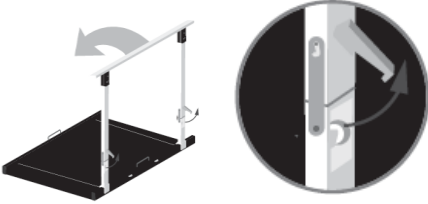

Please use the washer (8) and the adjustment knob (7) to fix the upper set and the lower set, and the indicator is assembled completely!

D. Foldable Handrail Assembly (SM-00001)

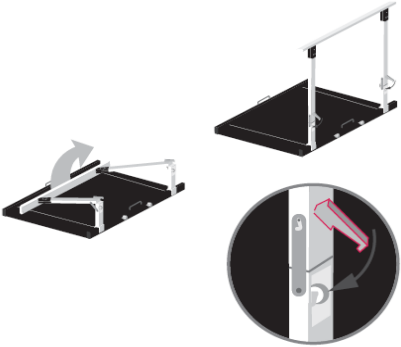
<p>To fold the handrail down, release the locking hook and carefully fold the handrail down.</p>	
<p>The hinge will lock in place, ready for transportation.</p>	
<p>Before raising handrail, place scale on solid, non-slippery, level surface.</p>	
<p>Raise the handrail until it is in upright position. Fix the locking hooks on the hinge back in place, and ensure the handrail is firmly secured.</p>	

V. Powering device

A. Using adapter and charging battery

The rechargeable battery should be recharged at least once every 3 months, regardless of if the device has been used. Battery can be charged by plugging device's exclusive adapter into AC Connector Port.

After a long period in storage (e.g. >3 months), the battery should run a full cycle (charge/discharge) to allow it to restore full capacity.

Ensure rechargeable battery housing is installed and inserted properly into the compartment.

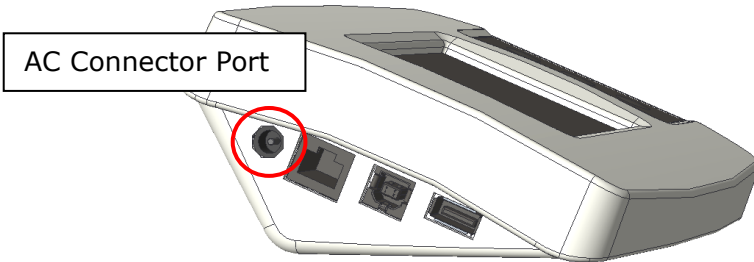

If  prompt displays on the LCD, please charge battery promptly to avoid battery damage.

B. Replacing Rechargeable Battery Pack

1. Open battery housing cover

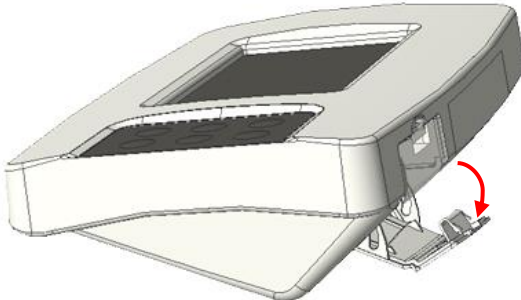

2. Accessing batteries

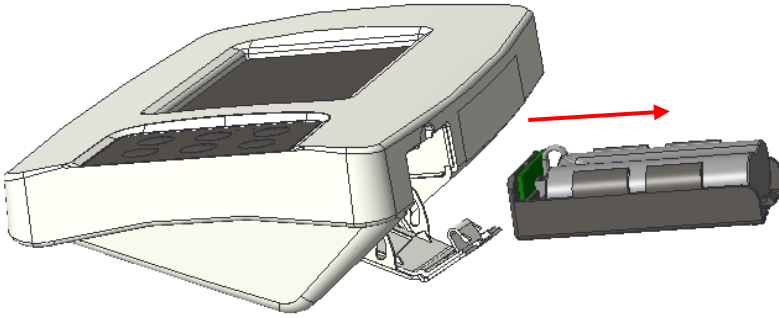

3. Place new battery pack into housing, and insert into indicator

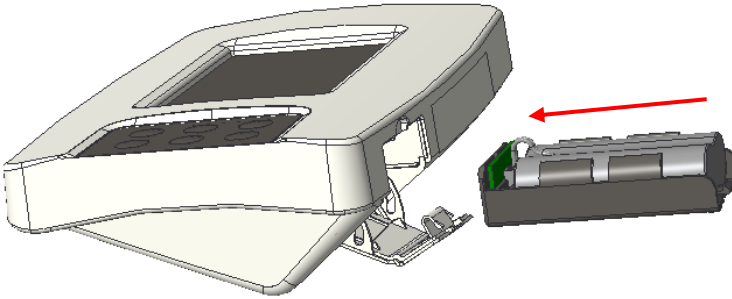

4. Close battery housing compartment cover. Turn on power to confirm that battery is correctly installed.

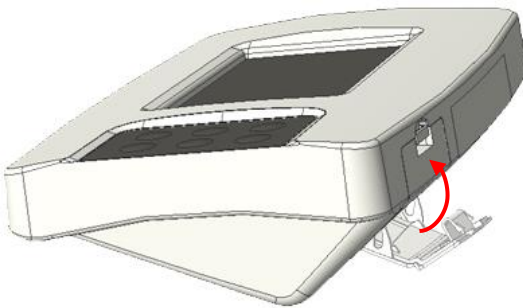

VI. Indicator

A. Indicator and Key Functions

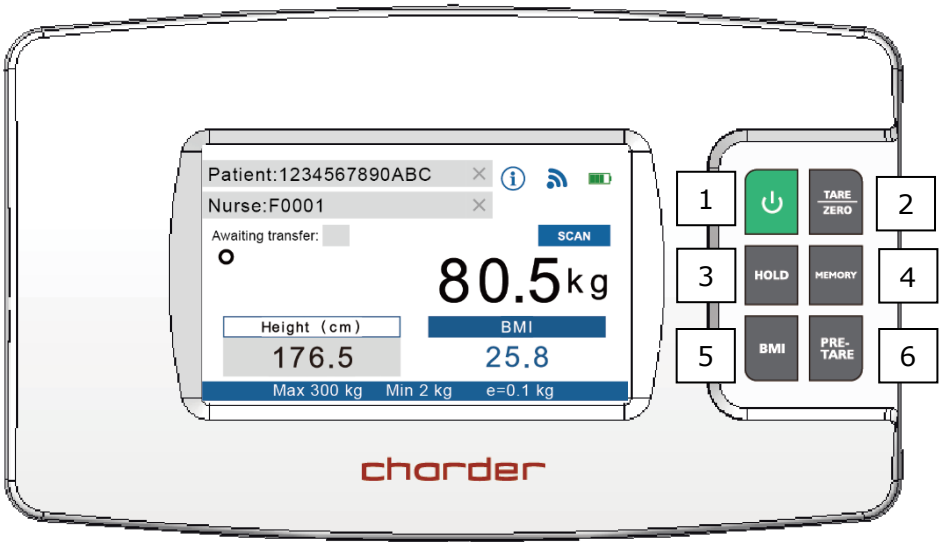

Key Function

1.  **POWER**: Power on or power off.
2. **TARE/ZERO**: Reset display to 0.0 kg display. Press and hold for 6 seconds to enter device settings.
3. **HOLD**: Determine stable weighing value - used when weight is unstable.
4. **MEMORY**: Save pre-tare values (up to 10 sets can be stored in device memory)
5. **BMI**: Calculation of Body Mass Index
6. **PRE-TARE**: Pre-tare the known weight of an object (ex: chair) before beginning measurement.

B. Display layout

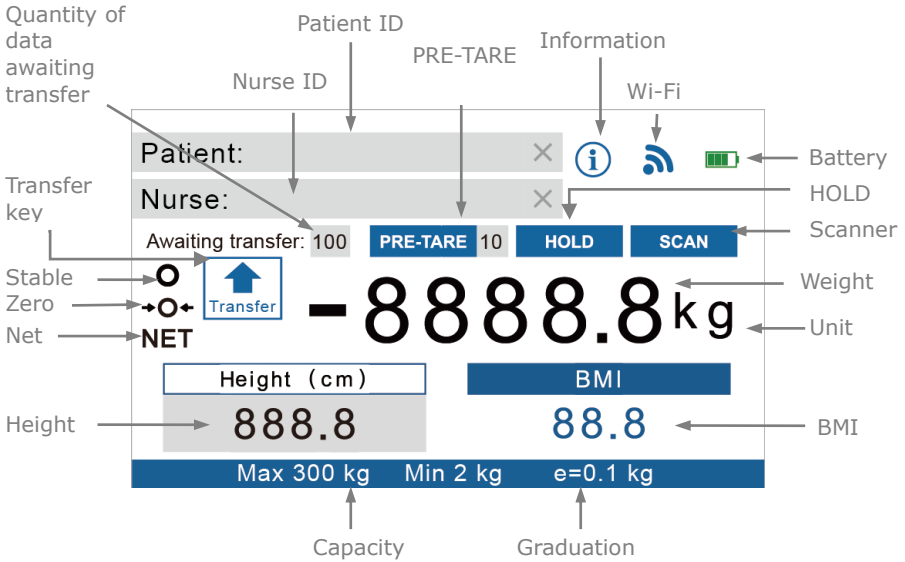

Definitions

Quantity of data awaiting transfer: If device is not connected wirelessly, measurement results will be temporarily stored in device. Once device is connected, operator can press **Transfer** to send results wirelessly. After transfer is complete, number will revert to "0"

PRE-TARE: If Pre-Tare function is active, this indicates which pre-tare value is being used.

HOLD: Will appear if Hold is active. (Hold needs to be activated in order to save and transfer results)

SCAN: Will appear if compatible barcode scanner is plugged into device

Transfer: After measurement is completed, height/weight result can be transferred wirelessly (if Hold is active). Press **[Transfer]** to send results.

Wi-Fi: Indicator will reflect current Wi-Fi connectivity status.



disconnected



connected

VII. Basic Operation

1. Switch on the device using  key. The device will automatically perform self-calibration
2. Once "0.0" appears on indicator, device is ready for use

NOTE: If "0.0" does not display on indicator, press **[TARE/ZERO]** key to zero the device.

A. Setup wireless data transfer Direct Wi-Fi data transfer

NOTE: If results do not need to be transferred after measurement, this step can be skipped.

1. The device acts as an Access Point that can be connected to via Wi-Fi. To ensure that the phone/tablet/PC connects to the correct device, first

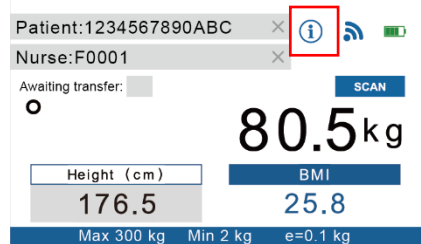

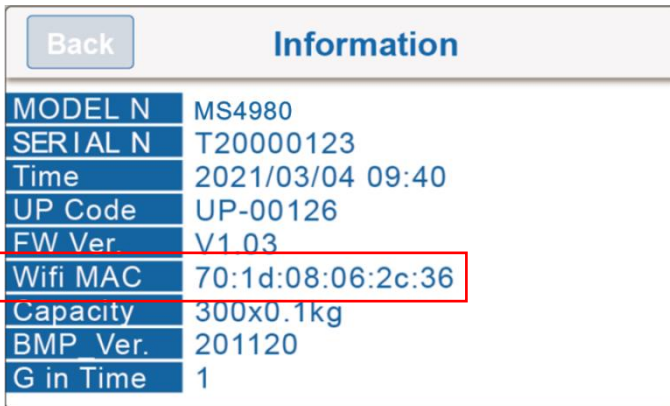

identify the device's MAC Address by clicking



2. The "name" of the device's Wi-Fi Access Point will be "DP4800_(MAC Address)" The default password to connect to the device is "0000000"

NOTE: The Model No. displayed in Information will vary depending on the device model.

3. After the phone/tablet/PC is connected to the device, the wireless

symbol will change from  to 

4. Device is now ready to send results wirelessly to phone/tablet/PC.

5. Before or after measurement, press the **[HOLD]** key. "HOLD" will be displayed on the indicator. If HOLD is not active, results cannot be transferred.

NOTE: by default, patient ID, weight, and height must be filled in to transfer results. Otherwise, **[Transfer]** button will not appear. To allow transfer of "incomplete" results, please change settings (press and hold **[TARE/ZERO]** key for 6 seconds to enter settings).

B. Pre-Tare

The Pre-Tare function is used to subtract the known weight of a wheelchair prior to weighing. The device can store 10 sets of pre-tare values in memory. Once pre-tare weights have been stored, they can be recalled by pressing the **[MEMORY]** key.

Input Pre-Tare Value

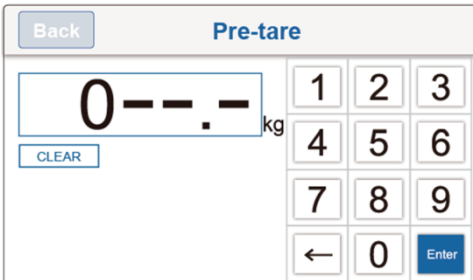
DESCRIPTION	EXAMPLE
<p>Press [PRE-TARE] key. Input pre-tare weight value, starting from the left</p>	
<p>Enter pre-tare weight using 0~9 keys.</p> <p>Ex: to pre-tare 5.0 kg of weight, press 0-0-5-0.</p> <p>Ex: to pre-tare 13.5 kg of weight, press 0-1-3-5.</p>	

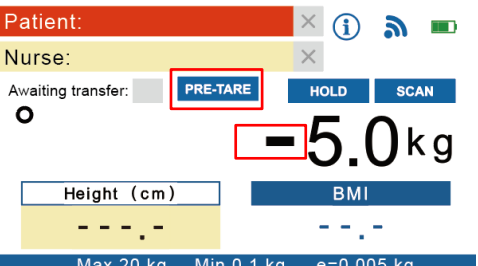
<p>(-0.5 kg used as example)</p> <p>Press [Enter] key to confirm the pre-tare weight.</p>	
<p>Device will return to measurement mode.</p> <p>Indicator will display minus sign to the left of pre-tare weight value.</p>	

Save a Pre-Tare value

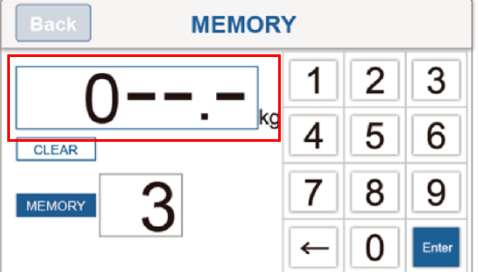
DESCRIPTION	EXAMPLE
<p>Press and hold [MEMORY] key for 3 seconds. Input the number for this pre-tare setting (between 01-10).</p> <p>Ex: To save memory set 3, press 0-3.</p>	
<p>Press the weight value box on the screen (marked in the red box to the right)</p> <p>Enter pre-tare weight using 0~9 keys.</p> <p>Ex: to pre-tare 13.5 kg of weight, press 0-1-3-5.</p>	

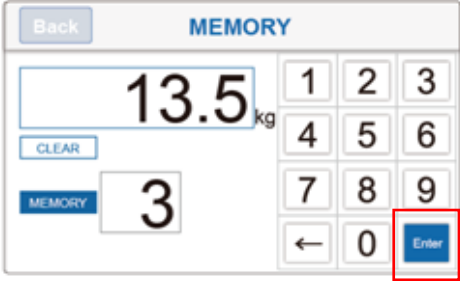
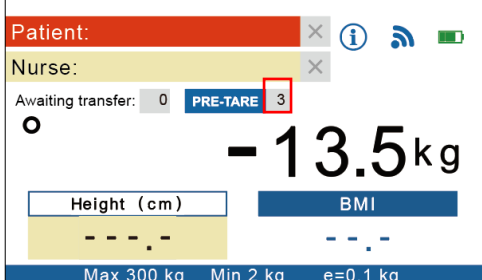
<p>Press [Enter] key to store pre-tare weight (saved to memory set 3, in this example)</p>	
<p>PRE-TARE ID will show Pre-Tare memory set 3 as active, and deduct the pre-tare value (13.5 kg, in this example) from the displayed weight result.</p>	

Recall Pre-Tare Value

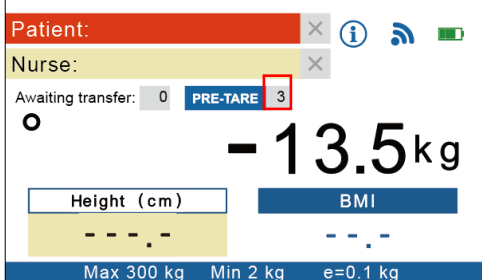
DESCRIPTION	EXAMPLE
<p>Press [MEMORY] key to toggle between Pre-Tare settings saved in device (between 01-10).</p> <p>NOTE: to add new Pre-Tare value, please press and hold [MEMORY] key for 3 seconds to enter settings (see "Save a Pre-Tare value" above)</p>	

C. Weight measurement

1. Select wheelchair weight to deduct from the stored Pre-Tare values using the **[MEMORY]** key. Push subject's wheelchair (with subject seated upon it) onto measurement platform. After a few seconds, the average weight will be displayed on the indicator. This weight will be locked - at this point, wheelchair containing subject can be removed.

2. If BMI calculation is unnecessary, press **[Transfer]** button to send results wirelessly. If device is not currently connected, results will temporarily be stored in device memory (number of records saved indicated by 'Awaiting transfer'). After transfer is complete, number will revert to "0"

D. BMI calculation

1. Press the **[BMI]** key to enter BMI mode.

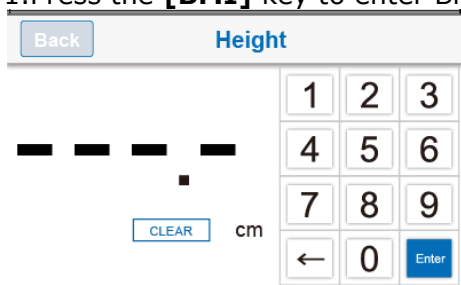

2. Enter height using numeral keys (ex: to input 170 cm, press 1-7-0-0). Press **[CLEAR]** key to re-input.

3. After inputting height, press **[Enter]** to confirm.

4. Proceed to weigh subject as usual. Indicator will display weight, height, and BMI.

5. To transfer results, ensure that HOLD is active, and press **[Transfer]** button to send results wirelessly. If device is not currently connected, results will temporarily be stored in device memory (number of records saved indicated by 'Awaiting transfer'). After transfer is complete, number will revert to "0"

Category	BMI (kg/m ²)	Risk of obesity-related disease
Under	< 18.5	Low
Normal	18.5-24.9	Average
Over	24.9-29.9	Slightly Increased
Obese I	30.0-34.9	Increased
Obese II	35.0-39.9	High
Obese III	> 40	Very High

(World Health Organization adult BMI standards)

VIII. Device Setup

Press and hold **[TARE/ZERO]** key for 6 seconds to enter General Setting mode.

EXIT		General	
Auto Off Time	180s	G-Compensation	-----
Backlight	High	URL Host	-----
Buzzer	On	Auto Hold	On
Optional Settings	-----	Auto Transfer	On
Date/Time	-----	Alarm Volume	High
Wifi Setting	-----		

Press menu options on the touchscreen to adjust settings.

Auto Off Time: Instruct device to shut off automatically after a certain period of time.

Auto off options: 120 sec / 180 sec / 240 sec / 300 sec / off

Backlight: adjust backlight brightness.

Options: Low / Mid / High

Buzzer: When function is turned on, beeping noise will be made when: indicator is turned on, keys are pressed, and weight is stable.

Options: Enable / Disable

Optional Settings:

1.If enabled patient ID or nurse ID, all data fields (patient ID or nurse ID , weight) need to be completed to transfer data.

If disable patient ID and nurse ID, meaning only got weight data is enough to make data transfer.

Additionally, if required field is not incomplete (ex. weight, or ID is missing), can't transfer data.

2.AUTO PRINT If the AUTO PRINT function in the settings is enabled, you can use the print stored data function. If the AUTO PRINT function in the settings is disabled, the print function will be unavailable.

A.

EXIT		General	
Auto Off Time	180s	G-Compensation	-----
Backlight	High	URL Host	-----
Buzzer	On	Auto Hold	On
Optional Settings	-----	Auto Transfer	On
Date/Time	-----	Alarm Volume	High
Wifi Setting	-----		

B.

Confirm		Optional Settings	
Mandatory NID :	Disable	Enable	
Mandatory PID :	Disable	Enable	
Auto print :	Disable	Enable	
Reserved 3 :	Disable	Enable	
Reserved 4 :	Disable	Enable	

Date/Time: Set device time. (Format: YYYY/MM/DD HH:M)

WiFi Setting: Send results via direct transfer or via network (set Access Point if selected)

G-Compensation: Authorized distributor can adjust gravity compensation value (password required)

H.M. Calibration: Calibrate ultrasonic height stadiometer

URL Host: Set IP address (ex: 192.168.0.1). Please note that if server is restarted, another IP may be automatically assigned. If IP change occurs, please re-input correct IP once more to complete settings.

Auto Hold: Determine if hold function will be automatically activated on start-up

Auto Transfer: Determine if results will be automatically transferred after measurement completion

IX. Connecting scale to receiving device

The scale is designed to transfer results wireless to receiving device. Please consult instruction manual for receiving device.

Connection directly to Electronic Medical System should be conducted by qualified distributors/administrators only.

X. Troubleshooting

Before contacting your local Charder distributor for repair service, we recommend considering the following troubleshooting procedures:

Self-inspection

1. Device will not power on

- If battery power is depleted, replace with new batteries
- If batteries are not used, check if the power adapter is plugged into the device properly. Check if power adapter is plugged into mains properly







2. Indicator showing "0000" ZERO SPAN out of range

- Interference due to factors such as RF disturbance or ground vibration. Relocate device to location without interference and try again
- Unstable platform feet - adjust platform feet according to bubble level indication (clockwise to retract, counter-clockwise to extend) and try again
- External objects interfering with measurement platform. Clear platform of objects and try again
- Device may not function properly on soft surfaces such as carpets or lawns. Relocate device to location with solid, stable floor
- If the steps above cannot resolve the problem, re-calibration may be required to correct weighing accuracy

3. Connection failure for data transmission to PC or printer

- Ensure wires are connected correctly between indicator and PC or printer
- Ensure printer is supplied with power. Ensure PC software is set up properly as indicated in this manual

Error Messages

Error Message	Action
<p> Low battery</p> <p>Please replace new batteries or plug the AC adaptor for operation.</p>	<p>Please charge battery using adapter, or replace battery</p>
<p> Overload</p> <p>Please reduce the loading and try again.</p>	<p>Maximum weight exceeded. Reduce weight on platform before attempting measurement</p>
<p> Loadcell error</p> <p>Please contact your nearest Authorized Dealer for further technician service & repair.</p>	<p>If problem persists, please contact distributor</p>
<p> Zero count over calibration zero range</p> <p>Please re-calibrate this instrument.</p>	<p>Re-calibration may be required. If problem persists, please contact distributor</p>
<p> Zero count under calibration zero range</p> <p>Please re-calibrate this instrument.</p>	<p>Re-calibration may be required. If problem persists, please contact distributor</p>
<p> ADC error</p> <p>Please contact your nearest Authorized Dealer for further technician service & repair.</p>	<p>If problem persists, please contact distributor</p>

XI. Product Specifications

Model		MS3880
Display		DP4800
Weight Measurement	Capacity	300 kg x 0.1 kg
	Accuracy	±1.5e
	LCD Screen	Color LCD touchscreen
Dimensions	Standard	Total: 1150(W) x 800(D) x 66(H) mm Platform: 900(L) x 740(P) mm
	XL	Total: 1500(W) x 860(D) x 68(H)mm Platform: 1200(L) x 800(P)mm
Device Weight	Standard	31.2 kg
	XL	46.7 kg
Key Functions		Power, Tare/Zero, Hold, Memory, BMI, Pre-Tare
Data Transmission		USB, Wireless NOTE: Device should be connected to network by qualified distributors only.
Power Supply		Rechargeable battery pack / adapter
Operation Environment		+5°C~+35°C 15% ~ 85% RH 700 hPa ~ 1060 hPa
Standard Accessories		User manual*1, Power Adapter*1
Optional Accessories		Handrail Set, Indicator Stand, Barcode Scanner



Warning

Only the original adapter should be used with the device. Using an adapter other than the one provided by Charder may cause malfunction.

Amp Voltage: 5V/2A

Drawing No: CD-AD-00023

AMP VOLTAGE	DRAWING NO.:	CE APPROVED TYPE NO. / MODEL NO.:	TYPE	Adapter plug
5V 2A	AD-00023	UES12LCP-050200SPC	US	
5V 2A	AD-00023	UES12LCP-050200SPC	EU	
5V 2A	AD-00023	UES12LCP-050200SPC	UK	
5V 2A	AD-00023	UES12LCP-050200SPC	AU	

XII. Declaration of Conformity

Manufacturer hereby declares that this product is in conformity with the regulations and standards outlined in the following directives:

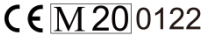
	(EU) 2017/745 Regulation on Medical Devices
	2014/31/EU Non-automatic Weighing Instruments Directive

RoHS Directive 2011/65/EU and Delegated Directive (EU) 2015/863

Radio equipment and telecommunications terminal equipment Directive 2014/53/EU

(applicable if device has wireless function)

Part 15 of the Federal Communications Statement Rules

This device may not cause harmful interference

This device must accept interference received without causing undesired operation

(Full Declaration of Conformity is available on manufacturer's website)

Authorized EU Representative:



Manufactured by:

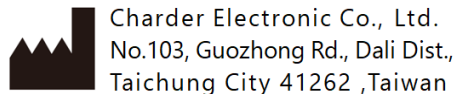

CD-IN-00402 REV008 03/2026