

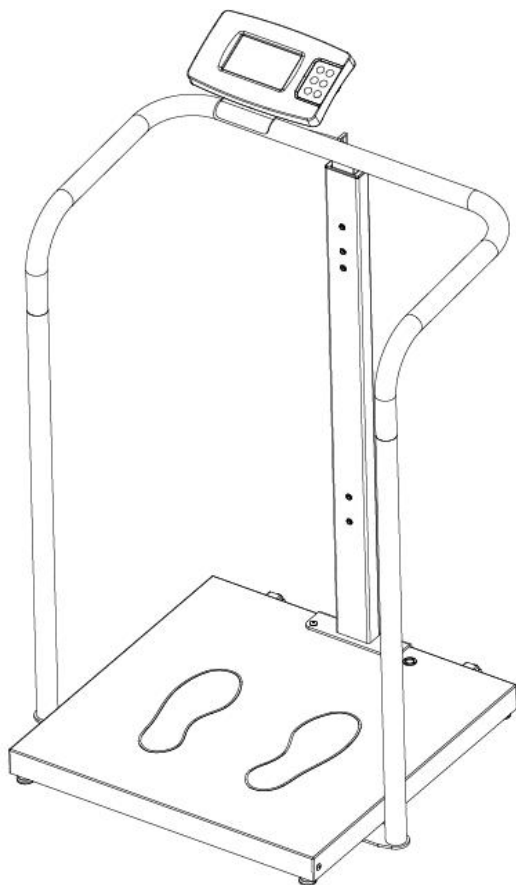

## Stand-on Floor Scale

# USER MANUAL MS2580















Please keep the instruction manual at hand and follow instruction for use.

# CONTENTS

- I. Explanation of Graphic Symbols on Label/Packaging .....3**
- II. Copyright Notice ..... 5**
- III. Safety Notes ..... 6**
  - A. General Information ..... 6
  - B. EMC Guidance and Manufacturer's Declaration ..... 10
- IV. Installation ..... 14**
  - A. Standard Parts ..... 14
  - B. Assembly .....15
  - C. Attaching indicator ..... 18
  - D. Using adapter and charging battery ..... 18
  - E. Replacing Rechargeable Battery Pack .....19
  - F. Optional Accessories ..... 20
- V. Indicator ..... 21**
  - A. Indicator and Key Functions .....21
  - B. Display layout ..... 22
- VI. Basic Operation ..... 23**
  - A. Setup wireless data transfer .....23
  - B. Weight measurement .....24
  - C. BMI calculation ..... 25
  - D. Tare ..... 26
  - E. Pre-Tare ..... 26
- VII. Device Setup ..... 29**
- VIII. Connecting scale to receiving device .....32**
- IX. Troubleshooting ..... 33**
  - Error Messages ..... 34
- X. Product Specifications ..... 35**
- XI. Declaration of Conformity ..... 40**

## I. Explanation of Graphic Symbols on Label/Packaging

Text/Symbol	Meaning
	Caution. Failure to follow instructions may result in adverse events
	Separate collection for waste of electrical and electronic equipment, in accordance with Directive 2002/96/EC. Do not dispose of device with everyday waste
	Name and address of device manufacturer
	Carefully read user manual before installation and usage, and follow instructions for use.
	Medical electrical device, Type B applied part
REF	Device catalogue number
	Name and address of authorized representative in the European Union (applicable for medical devices only)
	Device is a medical device. Text indicates device category type
	Manufacturer's batch or lot number for device
	Device's serial number
	Device's model number
	Device's Unique Device Identifier (01) GTIN (11) Production date (21) Serial number
e	Value in mass units. This is the difference between two consecutive display values, used to classify and verify a scale
	Device conforms to (EU) 2017/745 Regulation on Medical Devices. Four digit number is identifier for medical device Notified Body



Device claims conformity with essential regulations set by the relevant European Union legislation

CEM17 0122

Device complies with EU directives  
**M**: Conformity label in compliance with Directive 2014/31/EU for non-automatic weighing instruments  
**17**: Year in which conformity verification was performed and the CE label was applied. (ex: 17=2017)  
**0122**: Identifier for metrology Notified Body



Device is a Class III scale in compliance with Directive 2014/31/EU



Name and address of entity importing device



Name and address of entity responsible for translating Information For Use

CON.

Event counter recording how many times protected-mode parameter adjustments relating to metrology-related characteristics (ex: gravity value) have been conducted for device



Device has received Taiwan NCC approval



Device conforms to U.S. Federal Communications Commission regulations



Device complies with all UK applicable product legislation



Device's polarity of power.

**In case of differences, icon on device itself takes precedence.**

## II. Copyright Notice

### **Copyright Notice**

#### **Charder Electronic Co., Ltd.**

No.103, Guozhong Rd., Dali Dist., Taichung City 41262 Taiwan

Tel: +886-4-2406 3766

Fax: +886-4-2406 5612

Website: [www.chardermedical.com](http://www.chardermedical.com) E-mail:

[info\\_cec@charder.com.tw](mailto:info_cec@charder.com.tw)

Copyright© Charder Electronic Co., Ltd. All rights reserved. This user manual is protected by international copyright law. All content is licensed, and usage is subject to written authorization from Charder Electronic Co., Ltd. (hereinafter Charder) Charder is not liable for any damage caused by a failure to adhere to requirements stated in this manual. Charder reserves the right to correct misprints in the manual without prior notice, and modify the exterior of the device for quality purposes without customer consent.



Charder Electronic Co., Ltd.  
No. 103, Guozhong Rd., Dali Dist.,  
Taichung City, 41262 Taiwan

## III. Safety Notes

### A. General Information

Thank you for choosing this Charder Medical device. It is designed to be easy and straightforward to operate, but if you encounter any problems not addressed in this manual, please contact your local Charder service partner.

Before beginning operation of the device, please read this user manual carefully, and keep it in a safe place for reference. It contains important instructions regarding installation, proper usage, and maintenance.

### Intended Purpose

This medical device is designed to be used in accordance with national regulations, to measure weight within specifications, for weight-related usage by professionals.

### Clinical Benefit

Measurement results can be used by professionals to diagnose (and monitor) weight-related issues.

### Intended medical indications/contraindications

Measurement: patient's body weight. No known contraindications to measurement of body weight.

### Intended patient profile

- (a) Age: no restrictions
- (b) Weight: no restrictions within device weight capacity
- (c) Patient Conditions: require measurement of body weight.  
Able to stand independently without support.

### Intended user profile

- (a) At least 20 years old
- (b) Minimum knowledge:
  - To be able to read at a high-school level and understand Arabic numerals (e.g. 1, 2, 3, 4...)
  - Basic hygiene knowledge
  - Trained in device's operation
  - Read the instruction manual

- (c) Language
  - Able to read the language of instruction manual and on-screen instructions
- (d) Qualifications
  - No special certifications or qualifications required

### **Residual Risk Evaluation**

- (a) All foreseeable risks have been evaluated and considered acceptable. Generally speaking, the most likely risk caused by incorrect usage of the device is less accurate measurement (or inability to use device to acquire measurement), which does not pose imminent physical risk to patient or user.
- (b) Benefit-risk ratio is considered acceptable. Stand-on floor scales are an important option for measuring patients. Usage of device is unlikely to result in harm to user or patient.

### **General Handling**

- Device should be placed on stable, flat, solid, non-slippery surface.
- Usage on soft surfaces (ex: carpet) may result in inaccurate results.
- Ensure all parts are properly locked and tightened before operating the device.
- Device is intended to measure one subject at a time.

### **Safety Instructions**

- Batteries should be kept away from children. If swallowed, promptly seek medical assistance.
- The device has an expected service life of 5 years when correctly handled, serviced, and periodically inspected in accordance with manufacturer's instructions.
- Always comply with appropriate regulations when using electrical components under increased safety requirements.
- Ensure voltage marked on power supply matches mains power supply.
- The device is intended for indoor use only.
- Observe permissible ambient temperatures for use

## **Environmental**

- All batteries contain toxic compounds; batteries should be disposed of via designated competent organizations. Batteries should not be incinerated.

## **Cleaning**

- Device surface should be cleaned using alcohol-based wipes. Corrosive cleansing liquids should not be used. Pressure-washers should not be used.
- Do not use large amounts of water when cleaning the device, as it may cause damage to the internal electronics.
- Always disconnect device from mains power before cleaning.

## **Maintenance**

- Please contact your local Charder distributor for regular maintenance and calibration, regular checking of accuracy is recommended; frequency to be determined by level of use and state of device.

## **Warranty/Liability**

- The period of warranty shall be eighteen (18) months, beginning on the date of purchase. Please retain your receipt as proof of purchase.
- No responsibility shall be accepted for damage caused through any of the following reasons: unsuitable or improper storage or use, incorrect installation or commissioning by the owner or third parties, natural wear and tear, changes or modifications, incorrect or negligent handling, chemical, electrochemical, or electrical interference.
- All maintenance, technical inspections, and repairs should be conducted by an authorized Charder service partner, using original Charder accessories and spare parts. Charder is not liable for any damages arising from improper maintenance or usage.

## **Disposal**

- This product is not to be treated as regular household waste, but should be taken to a designated collection points for electronics. Further information should be provided by local waste disposal authorities.



## **Warning**

- Only the original adapter should be used with the device. Using an adapter other than the one provided by Charder may cause malfunction.
- Do not touch the power supply with wet hands.
- Do not crimp the power cable, and avoid sharp edges.
- Do not overload extension cables connected to the device.
- Route cables carefully, to avoid tripping.
- Keep device away from liquids.
- Do not remove the plug by yanking on the cable.
- Use only a correctly wired (100-240VAC) outlet, and do not use a multiple outlet extension cable.
- Do not under any circumstances dismantle or alter the device, as this could result in electric shock or injury as well as adversely affect the precision of measurements.
- Do not place the device in direct sunlight, or in close proximity to an intense heat source. Excessively high temperatures may damage the internal electronics.

## **Incident Reporting**

- Any serious incident that has occurred in relation to the device should be reported to the manufacturer, EU representative (if device is used in EU member state), and competent authority of user/subject's member state.

## B. EMC Guidance and Manufacturer's Declaration

<b>Guidance and manufacturer's declaration-electromagnetic emissions</b>		
<p>The product is intended for use in the electromagnetic environment specified below. The customer or the user of the product should assure that it is used in such an environment.</p>		
<b>Emission test</b>	<b>Compliance</b>	<b>Electromagnetic environment-guidance</b>
RF emissions CISPR 11	Group 1	The product uses RF energy only for its internal function. Therefore, its RF emissions are very low and are not likely to cause any interference in nearby electronic equipment.
RF emissions CISPR 11	Class A	The product is suitable for use in all establishments other than domestic and those directly connected to a low voltage power supply network which supplies buildings used for domestic purposes.
Harmonic emissions IEC 61000-3-2	Class A	
Voltage fluctuations/ Flicker emissions IEC 61000-3-3	Compliance	

## Guidance and manufacturer's declaration-electromagnetic immunity

The product is intended for use in the electromagnetic environment specified below. The customer or the user of the product should assure that it is used in such an environment.

Immunity test	IEC 60601 test level	Compliance level	Electromagnetic environment-guidance
Electrostatic discharge(ESD) IEC 61000-4-2	±8 kV contact ±2 kV, ±4 kV, ±8 kV, ±15 kV air	±8 kV contact ±2 kV, ±4 kV, ±8 kV, ±15 kV air	Floors should be wood, concrete or ceramic tile. If floors are covered with synthetic material, the relative humidity should be at least 30%
Electrical fast transient/burst IEC 61000-4-4	± 2kV for power supply lines	± 2kV for power supply lines	Mains power quality should be that of a typical commercial or hospital environment.
Surge IEC 61000-4-5	± 1kV line(s) to line(s) ± 2kV line(s) to earth	± 1kV line(s) to line(s) ± 2kV line(s) to earth	Mains power quality should be that of a typical commercial or hospital environment.
Voltage Dips, short interruptions and voltage variations on power supply input lines IEC 61000-4-11	0% UT for 0,5 cycle 0% UT for 1 cycle  70% UT(30% dip in UT) for 25cycles  0% UT for 5 s	0% UT for 0,5 cycle 0% UT for 1 cycle  70% UT(30% dip in UT) for 25cycles  0% UT for 5 s	Mains power quality should be that of a typical commercial or hospital environment. If the user of the product requires continued operation during power mains interruptions, it is recommended that the product be powered from an uninterruptible power supply or a battery.
Power frequency (50, 60 Hz) magnetic field IEC 61000-4-8	30 A/m	30 A/m	The product power frequency magnetic fields should be at levels characteristic of a typical location in a typical commercial or hospital environment.
NOTE UT is the a.c. mains voltage prior to application of the test level.			

## Guidance and manufacturer's declaration-electromagnetic immunity

The product is intended for use in the electromagnetic environment specified below. The customer or the user of the product should assure that is used in such and environment.

Immunity test	IEC 60601 test level	Compliance level	Electromagnetic environment-guidance
Conducted RF IEC 61000-4-6	3 Vrms 150 KHz to 80 MHz  6 V in ISM bands between 0,15 MHz and 80 MHz 80 % AM at 1 kHz	3 Vrms 150 KHz to 80 MHz  6 V in ISM bands between 0,15 MHz and 80 MHz 80 % AM at 1 kHz	Portable and mobile RF communications equipment should be used no closer to any part of the product including cables, than the recommended separation distance calculated from the equation applicable to the frequency of the transmitter.
Radiated RF IEC 61000-4-3	3 V/m 80MHz to 2,7 GHz	3 V/m 80MHz to 2,7 GHz	<p><b>Recommended separation distance:</b>  <math>d = 1,2 \sqrt{P}</math>  <math>d = 1,2 \sqrt{P}</math> 80MHz to 800 MHz  <math>d = 2,3 \sqrt{P}</math> 800MHz to 2,7GHz                      Where <math>P</math> is the maximum output power rating of the transmitter in watts (W) according to the transmitter manufacturer and <math>d</math> is the recommended separation distance in meters (m).</p> <p>Field strengths from fixed RF transmitters, as determined by an electromagnetic site survey, <sup>a</sup> should be less than the compliance level in each frequency range.<sup>b</sup></p> <p>Interference may occur in the vicinity of equipment marked with the following symbol:</p> <div style="text-align: center;">  </div>

NOTE1 At 80 MHz and 800 MHz, the higher frequency range applies.

NOTE2 These guidelines may not apply in all situations. Electromagnetic propagation is affected by absorption and reflection from structures, objects and people.

- a Field strengths from fixed transmitters, such as base stations for radio (cellular/cordless) telephones and land mobile radios, amateur radio, AM and FM radio broadcast and TV broadcast cannot be predicted theoretically with accuracy. To assess the electromagnetic environment due to fixed RF transmitters, an electromagnetic site survey should be considered. If the measured field strength in the location in which the product is used exceeds the applicable RF compliance level above, the product should be observed to verify normal operation. If abnormal performance is observed, additional measures may be necessary, such as re-orienting or relocating the product.
- b Over the frequency range 150 kHz to 80 MHz, field strengths should be less than 3V/m.

<b>Recommended separation distance between portable and mobile RF communications equipment and the product</b>			
The product is intended for use in an electromagnetic environment in which radiated RF disturbances are controlled. The customer or the user of the product can help prevent electromagnetic interference by maintaining a minimum distance between portable and mobile RF communications equipment (transmitters) and the product as recommended below, according to the maximum output power of the communications equipment.			
<b>Rated maximum output power of transmitter</b> W	<b>Separation distance according to frequency of transmitter m</b>		
	<b>150 kHz to 80 MHz</b>	<b>80 MHz to 800 MHz</b>	<b>800 MHz to 2,7 GHz</b>
	$d = 1,2\sqrt{P}$	$d = 1,2\sqrt{P}$	$d = 2,3\sqrt{P}$
0,01	0,12	0,12	0,23
0,1	0,38	0,38	0,73
1	1,2	1,2	2,3
10	3,8	3,8	7,3
100	12	12	23
For transmitters rated at a maximum output power not listed above, the recommended separation distance d in meters (m) can be estimated using the equation applicable to the frequency of the transmitter, where p is the maximum output power rating of the transmitter in watts (W) according to the transmitter manufacturer.			
NOTE1 At 80 MHz and 800 MHz, the separation distance for the higher frequency range applies.			
NOTE2 These guidelines may not apply in all situations. Electromagnetic propagation is affected by absorption and reflection from structures, objects and people.			

## IV. Installation

### A. Standard Parts

No.	Accessories	Item	Spec.	Qty.
1		Truss head hex socket screws (for columns)	M5*0.8*20	6
2		Round head hex socket screws (for Attach handrail columns)	M8*1.25*25	2
3		Knob screw	M4*8	4
4		User Manual	IN-01991	1
5		USB transfer cable	B-type	1
6		Hex Wrench	M3	1
7		Hex Wrench	M5	1

# B. Assembly

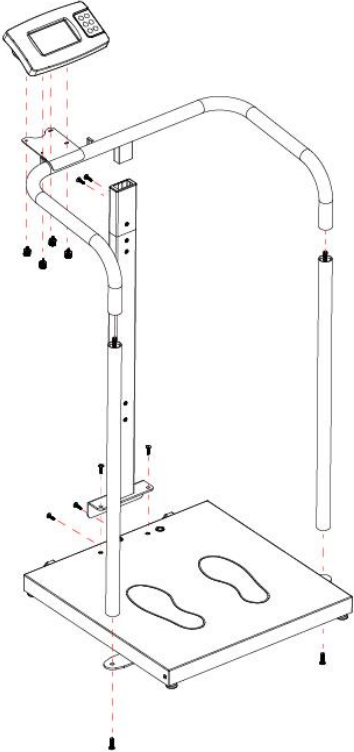

1. Attach round tube to handrail column

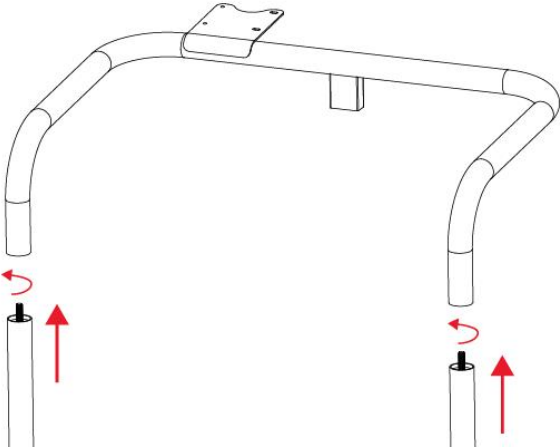

2. Attach center column to the platform.

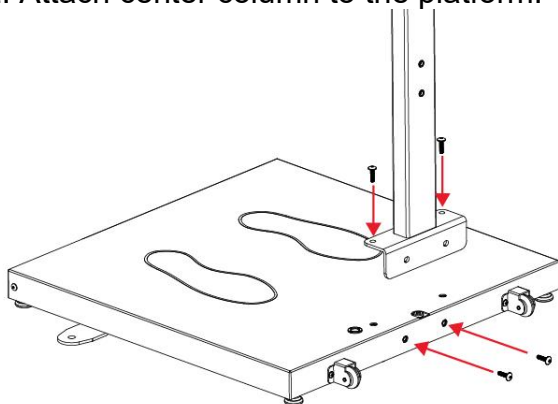

3. Attach handrail column assembly to center column.

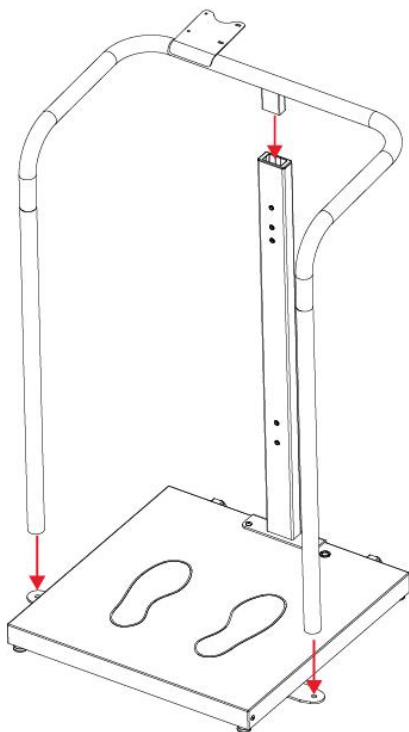

4. Attach handrail to column with screws.

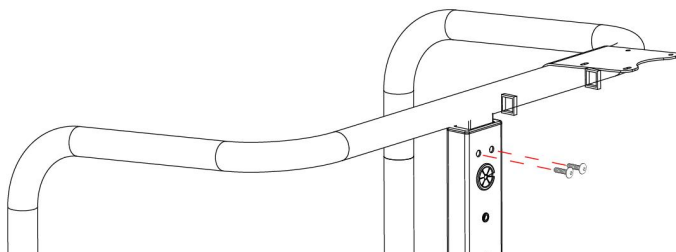

5. Tilt the scale.

Attach handrail to the platform bracket with screws.

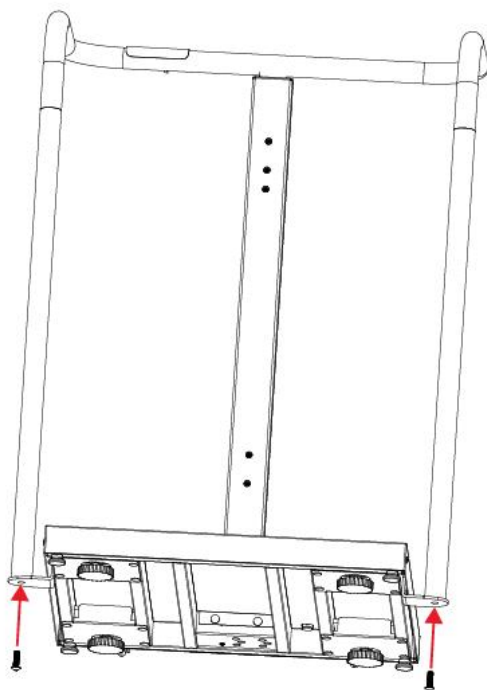

**NOTE:** Ensure that screws are securely tightened for patient safety

## C. Attaching indicator

1. Ensure screws securing indicator to handrail are tight

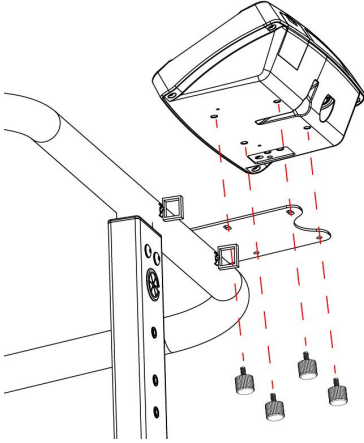



## D. Using adapter and charging battery

The rechargeable battery should be recharged at least once every 3 months, regardless of if the device has been used. Battery can be charged by plugging device's exclusive adapter into AC Connector Port.

After a long period in storage (e.g. >3 months), the battery should run a full cycle (charge/discharge) to allow it to restore full capacity.

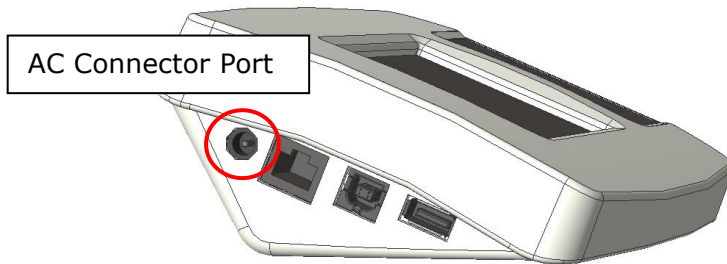
Ensure rechargeable battery housing is installed and inserted properly into the compartment.



If  prompt displays on the LCD, please charge battery promptly to avoid battery damage.

## E. Replacing Rechargeable Battery Pack

1. Open battery housing cover

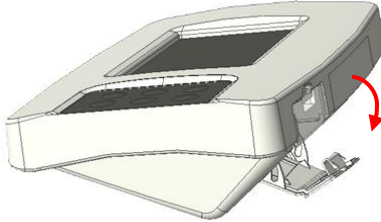

2. Remove battery pack housing from indicator

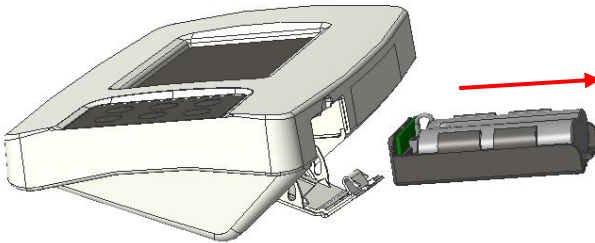

3. Place new battery pack into housing, and insert into indicator

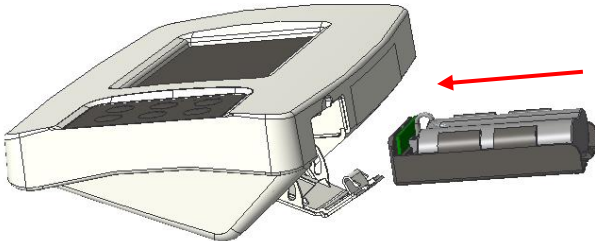

4. Close battery housing compartment cover. Turn on power to confirm that battery is correctly installed.

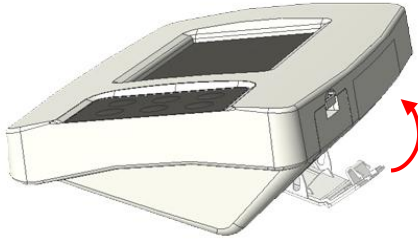

## **F. Optional Accessories**

This device is compatible with a variety of accessories. Please consult their respective user manuals for assembly instructions:

### **a. Height Stadiometer**

- HM200D Digital Height Stadiometer
- HM200U Ultrasonic Height Stadiometer
- HM201D Digital Height Stadiometer
- HM201M Mechanical Height Stadiometer

### **b. Barcode Scanner**

- AS-9300 Infrared Barcode Scanner

## V. Indicator

### A. Indicator and Key Functions

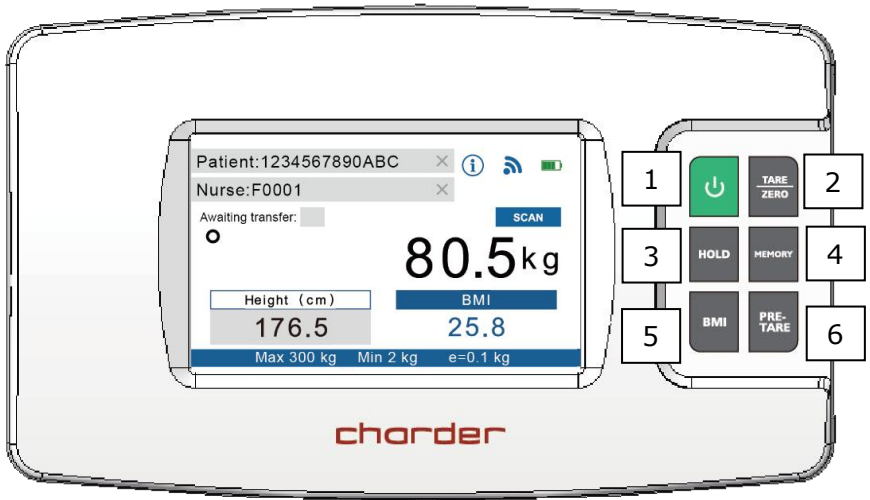

### Key Function

1.  **POWER**: Power on or power off.
2. **TARE/ZERO**: Reset display to 0.0 kg display. Press and hold for 6 seconds to enter device settings.
3. **HOLD**: Determine stable weighing value - used when weight is unstable.
4. **MEMORY**: Save pre-tare values (up to 10 sets can be stored in device memory)
5. **BMI**: Calculation of Body Mass Index
6. **PRE-TARE**: Pre-tare the known weight of an object (ex: chair) before beginning measurement.

## B. Display layout

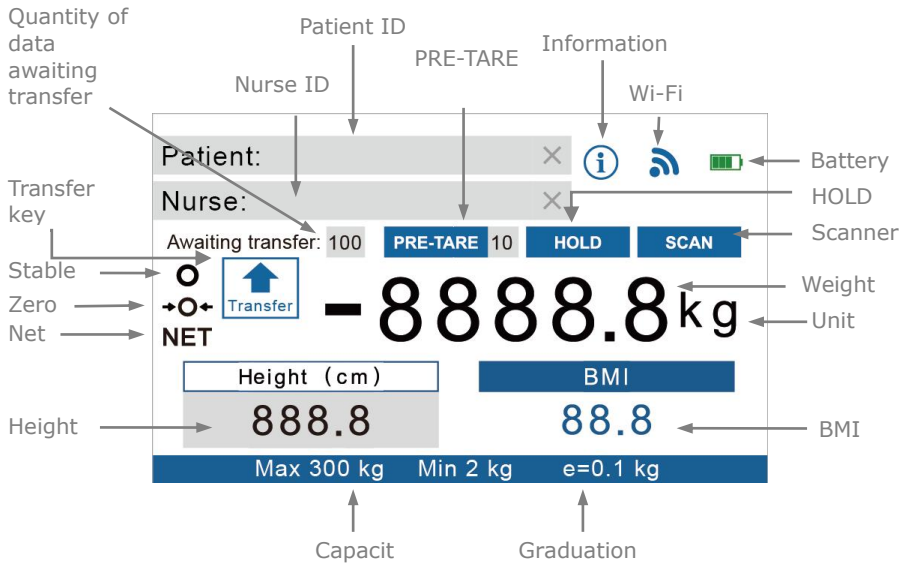

### Definitions

**Quantity of data awaiting transfer:** If device is not connected wirelessly, measurement results will be temporarily stored in device. Once device is connected, operator can press **Transfer** to send results wirelessly. After transfer is complete, number will revert to "0"

**PRE-TARE:** If Pre-Tare function is active, this indicates which pre-tare value is being used.

**HOLD:** Will appear if Hold is active.  
(Hold needs to be activated in order to save and transfer results)

**SCAN:** Will appear if compatible barcode scanner is plugged into device

**Transfer:** After measurement is completed, height/weight result can be transferred wirelessly (if Hold is active).  
Press **[Transfer]** to send results.

**Wi-Fi:** Indicator will reflect current Wi-Fi connectivity status.



disconnected



connected

## VI. Basic Operation

1. Switch on the device using  key. The device will automatically perform self-calibration
2. Once "0.0" appears on indicator, device is ready for use

**NOTE:** If "0.0" does not display on indicator, press [**TARE/ZERO**] key to zero the device.

### A. Setup wireless data transfer Direct Wi-Fi data transfer

**NOTE:** If results do not need to be transferred after measurement, this step can be skipped.

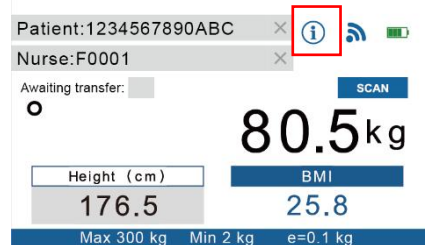

1. The device acts as an Access Point that can be connected to via Wi-Fi. To ensure that the phone/tablet/PC connects to the correct device, first identify the device's MAC Address by

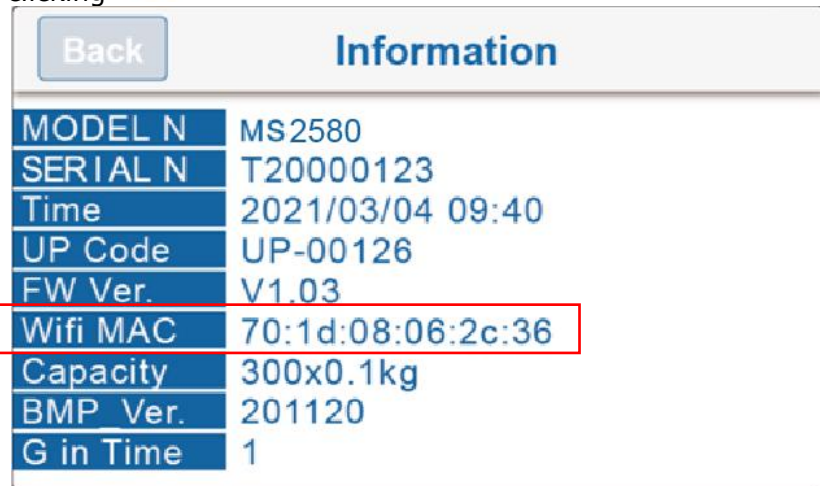

clicking 



2. The "name" of the device's Wi-Fi Access Point will be "DP4800\_(MAC Address)" The default password to connect to the device is "00000000"

**NOTE:** The Model No. displayed in Information will vary depending on the device model.

3. After the phone/tablet/PC is connected to the device, the

wireless symbol will change from  to 

4. Device is now ready to send results wirelessly to phone/tablet/PC.

5. Before or after measurement, press the **[HOLD]** key. "HOLD" will be displayed on the indicator. If HOLD is not active, results cannot be transferred.

**NOTE:** by default, patient ID, weight, and height must be filled in to transfer results. Otherwise, **[Transfer]** button will not appear. To allow transfer of "incomplete" results, please change settings (press and hold **[TARE/ZERO]** key for 6 seconds to enter settings).

## **B. Weight measurement**

1. Guide subject to stand upon the measurement platform. After a few seconds, the average weight will be displayed on the indicator. This weight will be locked - at this point, subject can step off from device.

2. If BMI calculation is unnecessary, press **[Transfer]** button to send results wirelessly. If device is not currently connected, results will temporarily be stored in device memory (number of records saved indicated by 'Awaiting transfer'). After transfer is complete, number will revert to "0"

## C. BMI calculation

### Manual Input

1. Press the **[BMI]** key to enter BMI mode.

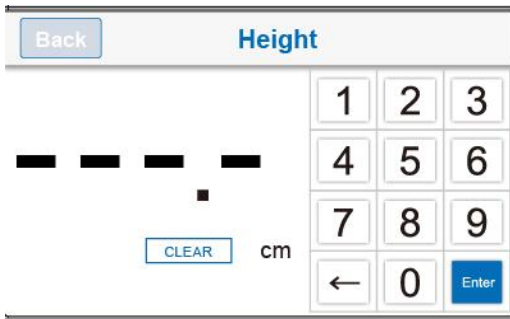

2. Enter height using numeral keys (ex: to input 170 cm, press 1-7-0-0). Press **[CLEAR]** key to re-input.

3. After inputting height, press **[Enter]** to confirm.

4. Proceed to weigh subject as usual. Indicator will display weight, height, and BMI.

5. To transfer results, ensure that HOLD is active, and press **[Transfer]** button to send results wirelessly. If device is not currently connected, results will temporarily be stored in device memory (number of records saved indicated by 'Awaiting transfer'). After transfer is complete, number will revert to "0"

### With attached Height Stadiometer

1. Ensure compatible Charder digital height stadiometer is plugged into indicator. If stadiometer is plugged in, manual height input will be disabled.

2. Proceed to weigh subject as usual. Adjust head stopper of attached stadiometer accordingly. (HM200U Ultrasonic Height Stadiometer will automatically measure height) Indicator will display weight, height, and BMI.

3. To transfer results, ensure that HOLD is active, and press **[Transfer]** button to send results wirelessly. If device is not currently connected, results will temporarily be stored in device memory (number of records saved indicated by 'Awaiting transfer'). After transfer is complete, number will revert to "0"

<b>Category</b>	<b>BMI (kg/m<sup>2</sup>)</b>	<b>Risk of obesity-related disease</b>
Under	< 18.5	Low
Normal	18.5-24.9	Average
Over	24.9-29.9	Slightly Increased
Obese I	30.0-34.9	Increased
Obese II	35.0-39.9	High
Obese III	> 40	Very High

(World Health Organization adult BMI standards)

#### **D. Tare**

The tare function allows the user to deduct the weight of objects from the device's measurement result.

1. Place object that needs to be tared onto measurement platform.
2. Press **[TARE/ZERO]** key after stable symbol appears on indicator. Display will indicate "0.0".
3. Guide subject (plus tared object) to be weighed upon measurement platform. Conduct measurement.
4. To clear tare value, remove all objects from measurement platform, and press **[TARE/ZERO]** key.



#### **E. Pre-Tare**

The Pre-Tare function is used to subtract the known weight of a substance prior to weighing. The device can store 10 sets of pre-tare values in memory. Once pre-tare weights have been stored, they can be recalled by pressing the **[MEMORY]** key.

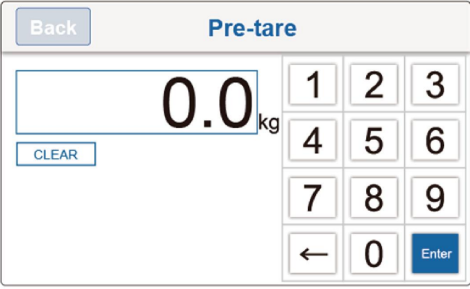
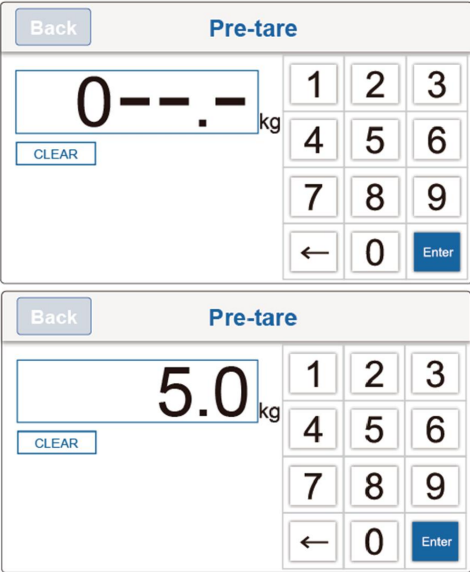
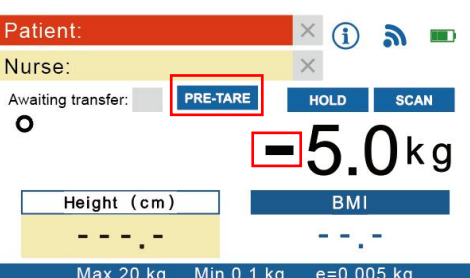
## Input Pre-Tare Value

DESCRIPTION	EXAMPLE
<p>Press <b>[PRE-TARE]</b> key. Input pre-tare weight value, starting from the left</p>	
<p>Enter pre-tare weight using 0~9 keys.</p> <p>Ex: to pre-tare 5.0 kg of weight, press 0-0-5-0.</p> <p>Ex: to pre-tare 13.5 kg of weight, press 0-1-3-5.</p> <p>Press <b>[Enter]</b> key to confirm the pre-tare weight.</p>	
<p>Device will return to measurement mode.</p> <p>Indicator will display minus sign to the left of pre-tare weight value.</p>	

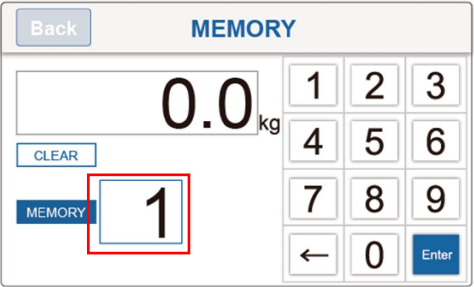
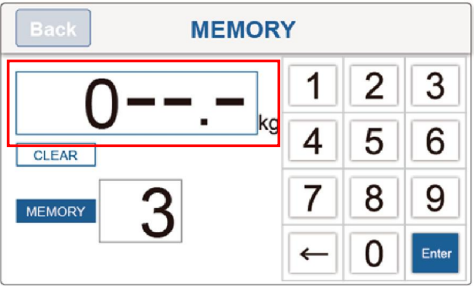
## Save a Pre-Tare value

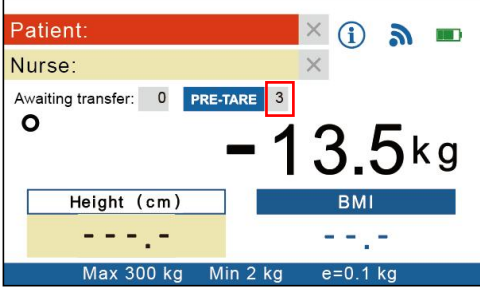
DESCRIPTION	EXAMPLE
<p>Press and hold <b>[MEMORY]</b> key for 3 seconds. Input the number for this pre-tare setting (between 01-10).</p> <p>Ex: To save memory set 3, press 0-3.</p>	
<p>Press the weight value box on the screen (marked in the red box to the right)</p> <p>Enter pre-tare weight using 0~9 keys.</p> <p>Ex: to pre-tare 13.5 kg of weight, press 0-1-3-5.</p>	
<p>Press <b>[Enter]</b> key to store pre-tare weight (saved to memory set 3, in this example)</p>	
<p>PRE-TARE ID will show Pre-Tare memory set 3 as active, and deduct the pre-tare value (13.5 kg, in this example) from the displayed weight result.</p>	

## Recall Pre-Tare Value

DESCRIPTION	EXAMPLE
<p>Press <b>[MEMORY]</b> key to toggle between Pre-Tare settings saved in device (between 01-10).</p> <p><b>NOTE:</b> to add new Pre-Tare value, please press and hold <b>[MEMORY]</b> key for 3 seconds to enter settings (see "Save a Pre-Tare value" above)</p>	 <p>The screenshot shows a scale's user interface. At the top, there are fields for 'Patient:' (red background) and 'Nurse:' (yellow background), each with a close button (X) and an information icon (i). Below these are 'Awaiting transfer:' (0) and 'PRE-TARE' (3), with the '3' highlighted in a red box. A large weight display shows '- 13.5 kg'. Below the weight are two input fields: 'Height (cm)' (yellow background) and 'BMI' (blue background), both containing dashes. At the bottom, a blue bar displays 'Max 300 kg', 'Min 2 kg', and 'e=0.1 kg'.</p>

## VII. Device Setup

Press and hold **[TARE/ZERO]** key for 6 seconds to enter General Setting mode.

EXIT		General	
Auto Off Time	180s	G-Compensation	-----
Backlight	High	URL Host	-----
Buzzer	On	Auto Hold	On
Optional Settings	-----	Auto Transfer	On
Date/Time	-----	Alarm Volume	High
Wifi Setting	-----		

Press menu options on the touchscreen to adjust settings.

**Auto Off Time:** Instruct device to shut off automatically after a certain period of time.

Auto off options: 120 sec / 180 sec / 240 sec / 300 sec / off

**Backlight:** adjust backlight brightness.

Options: Low / Mid / High

**Buzzer:** When function is turned on, beeping noise will be made when: indicator is turned on, keys are pressed, and weight is stable.

Options: Enable / Disable

### Optional Settings:

1.If enabled patient ID or nurse ID, all data fields (patient ID or nurse ID , weight) need to be completed to transfer data.

If disable patient ID and nurse ID, meaning only got weight data is enough to make data transfer.

Additionally, if required field is not incomplete (ex. weight, or ID is missing), can't transfer data.

2.AUTO PRINT If the AUTO PRINT function in the settings is enabled, you can use the print stored data function. If the AUTO PRINT function in the settings is disabled, the print function will be unavailable.

A.

EXIT		General	
Auto Off Time	180s	G-Compensation	-----
Backlight	High	URL Host	-----
Buzzer	On	Auto Hold	On
Optional Settings	-----	Auto Transfer	On
Date/Time	-----	Alarm Volume	High
Wifi Setting	-----		

B.

Confirm		Optional Settings	
Mandatory NID :	Disable	Enable	
Mandatory PID :	Disable	Enable	
Auto print :	Disable	Enable	
Reserved 3 :	Disable	Enable	
Reserved 4 :	Disable	Enable	

**Date/Time:** Set device time. (Format: YYYY/MM/DD HH:M)

**Wifi Setting:** Send results via direct transfer or via network (set Access Point if selected)

**G-Compensation:** Authorized distributor can adjust gravity compensation value (password required)

**H.M. Calibration:** Calibrate ultrasonic height stadiometer

**URL Host:** Set IP address (ex: 192.168.0.1). Please note that if server is restarted, another IP may be automatically assigned. If IP change occurs, please re-input correct IP once more to complete settings.

**Auto Hold:** Determine if hold function will be automatically activated on start-up

**Auto Transfer:** Determine if results will be automatically transferred after measurement completion

## VIII. Connecting scale to receiving device

The device can transfer results to receiving device. Please consult instruction manual for receiving device.

Connection directly to Electronic Medical System should be conducted by qualified distributors/administrators only.

**NOTE:** Wireless transfer is only available on wireless model.

## IX. Troubleshooting

Before contacting your local Charder distributor for repair service, we recommend considering the following troubleshooting procedures:

### Self-inspection

#### 1. Device will not power on

- If battery power is depleted, replace with new batteries
- If batteries are not used, check if the power adapter is plugged into the device properly. Check if power adapter is plugged into mains properly







#### 2. Indicator showing "00000" ZERO SPAN out of range

- Interference due to factors such as RF disturbance or ground vibration. Relocate device to location without interference and try again
- Unstable platform feet - adjust platform feet according to bubble level indication (clockwise to retract, counter-clockwise to extend) and try again
- External objects interfering with measurement platform. Clear platform of objects and try again
- Device may not function properly on soft surfaces such as carpets or lawns. Relocate device to location with solid, stable floor
- If the steps above cannot resolve the problem, re-calibration may be required to correct weighing accuracy

#### 3. Connection failure for data transmission to PC or printer

- Ensure wires are connected correctly between indicator and PC or printer
- Ensure printer is supplied with power. Ensure PC software is set up properly as indicated in this manual

## Error Messages

Error Message	Action
<p> <b>Low battery</b></p> <p>Please replace new batteries or plug the AC adaptor for operation.</p>	<p>Please charge battery using adapter, or replace battery</p>
<p> <b>Overload</b></p> <p>Please reduce the loading and try again.</p>	<p>Maximum weight exceeded. Reduce weight on platform before attempting measurement</p>
<p> <b>Loadcell error</b></p> <p>Please contact your nearest Authorized Dealer for further technician service &amp; repair.</p>	<p>If problem persists, please contact distributor</p>
<p> <b>Zero count over calibration zero range</b></p> <p>Please re-calibrate this instrument.</p>	<p>Re-calibration may be required. If problem persists, please contact distributor</p>
<p> <b>Zero count under calibration zero range</b></p> <p>Please re-calibrate this instrument.</p>	<p>Re-calibration may be required. If problem persists, please contact distributor</p>
<p> <b>ADC error</b></p> <p>Please contact your nearest Authorized Dealer for further technician service &amp; repair.</p>	<p>If problem persists, please contact distributor</p>

## X. Product Specifications

<b>Model</b>		<b>MS2580</b>
<b>Display</b>		DP4800
<b>Weight Measurement</b>	<b>Capacity</b>	300 kg x 0.1 kg
	<b>Accuracy</b>	±1.5e
	<b>LCD Screen</b>	Color LCD touchscreen
<b>Dimensions</b>	<b>Overall</b>	660(W) x 550(D) x 1090(H) mm
	<b>Platform</b>	660(W) x 550(D) mm
<b>Device Weight</b>		20.8 kg
<b>Key Functions</b>		Power, Tare/Zero, Hold, Memory, BMI, Pre-Tare
<b>Data Transmission</b>		USB, Wireless <b>NOTE :</b> Device should be connected to network by qualified distributors only.
<b>Power Supply</b>		Rechargeable battery pack / adapter
<b>Operation Environment</b>		+5°C~+35°C 15% ~ 85% RH 700 hPa ~1060 hPa
<b>Standard Accessories</b>		(see accessory list)
<b>Optional Accessories</b>		Thermal Printer, Height Stadiometer, Barcode Scanner



### **Warning**

The device is only compatible with the manufacturer's power adapter.

Amp Voltage: 5V/2A

Drawing No: CD-AD-00023

<b>AMP VOLTAGE</b>	<b>DRAWING NO.:</b>	<b>CE APPROVED TYPE NO. / MODEL NO.:</b>	<b>TYPE</b>	<b>Adapter plug</b>
5V 2A	AD-00023	UES12LCP-050200SPC	US	
5V 2A	AD-00023	UES12LCP-050200SPC	EU	
5V 2A	AD-00023	UES12LCP-050200SPC	UK	
5V 2A	AD-00023	UES12LCP-050200SPC	AU	







## XI. Declaration of Conformity

Manufacturer hereby declares that this product is in conformity with the regulations and standards outlined in the following directives:



**RoHS Directive 2011/65/EU and Delegated Directive (EU) 2015/863**

**Radio equipment and telecommunications terminal equipment Directive 2014/53/EU**  
(applicable if device has wireless function)

### **Part 15 of the Federal Communications Statement Rules**

This device may not cause harmful interference  
This device must accept interference received without causing undesired operation

(Full Declaration of Conformity is available on manufacturer's website)

#### **Manufactured by:**



Charder Electronic Co., Ltd.  
No.103, Guozhong Rd., Dali Dist.,  
Taichung City 41262 ,Taiwan

CD-IN-02160 REV001 01/2026