



## Infant Scale

USER MANUAL

**MS2400**

Infant Scale

















Please keep the instruction manual at hand and follow instruction for use.



# CONTENTS

<b>Explanation of Graphic Symbols on Label/Packaging .....</b>	<b>4</b>
<b>I. Safety Notes .....</b>	<b>7</b>
A. General Information.....	7
B. EMC Guidance and Manufacturer's Declaration ....	11
<b>II. Installation.....</b>	<b>15</b>
A. Height Measure Attachment .....	15
B. Inserting Batteries .....	17
C. Using AC Adapter .....	17
<b>III. Indicator.....</b>	<b>18</b>
A. Indicator and Key Functions .....	18
B. Key Functions .....	18
<b>IV. Using Device .....</b>	<b>19</b>
A. Basic Operation .....	19
B. Tare .....	19
C. Recall.....	20
<b>V. Device Setup .....</b>	<b>21</b>
<b>VI. Troubleshooting.....</b>	<b>23</b>
<b>VII. Product Specifications.....</b>	<b>26</b>
A. Device Information .....	26
B. Power Adapter Standards .....	27
<b>VIII. Declaration of Conformity.....</b>	<b>28</b>

# Explanation of Graphic Symbols on Label/Packaging

Text/Symbol	Meaning
	Caution, consult accompanying documents before use
	Separate collection for waste of electrical and electronic equipment, in accordance with Directive 2002/96/EC. Do not dispose of device with everyday waste
	Name and address of device manufacturer, and year/country of manufacture
	Carefully read user manual before installation and usage, and follow instructions for use.
	Medical electrical device, Type B applied part
	Medical electrical device, Type BF applied part
	Device catalogue number / model number
	Name and address of authorized representative in the European Union
	Device is a medical device. Text indicates device category type
	Manufacturer's batch or lot number for device
	Device's serial number
	Device's Unique Device Identifier
	Verification Scale Interval. Value expressed in units of mass. Used to classification and verification of an instrument.
	Device conforms to (EU) 2017/745 Regulation on Medical Devices. Fourdigit number is identifier for medical device Notified Body

Device complies with EC directives (verified models only)

CE **M20** 0122

**M**: Conformity label in compliance with Directive 2014/31/EU for non-automatic weighing instruments  
**20**: Year in which conformity verification was performed and the CE label was applied. (ex: 16=2016)  
**0122**: Identifier for metrology Notified Body



Device is a Class III scale in compliance with Directive 2014/31/EU (verified models only)



Name and address of entity importing device (if applicable)



Name and address of entity responsible for translating Information For Use (if applicable)

---

CON.

Event counter confirming how many times device has been calibrated (if applicable)



Device conforms to Taiwan National Communications Commission (NCC) approval



Device conforms to U.S. Federal Communications Commission regulations

---

UK **M 20** 8506  
CA

Device complies with UK non-automatic weighing instruments regulations 2016 (verified models only)  
**M**: Conformity label in compliance with Non-automatic Weighing instruments Regulations 2016  
**20**: Year in which conformity verification was performed and the UKCA label was applied. (ex: 20=2020)  
**8506**: Identifier for metrology approved body



Device complies with all UK applicable product legislation



Device's polarity of power.

**"In case of differences, icon on device itself takes precedence"**

## **Copyright Notice**

### **Charder Electronic Co., Ltd.**

No.103, Guozhong Rd., Dali Dist., Taichung City 41262 Taiwan

Tel: +886-4-2406 3766

Fax: +886-4-2406 5612

Website: [www.chardermedical.com](http://www.chardermedical.com)

E-mail: [info\\_cec@charder.com.tw](mailto:info_cec@charder.com.tw)

Copyright© Charder Electronic Co., Ltd. All rights reserved.  
This user manual is protected by international copyright law.  
All content is licensed, and usage is subject to written authorization from Charder Electronic Co., Ltd. (hereinafter Charder) Charder is not liable for any damage caused by a failure to adhere to requirements stated in this manual. Charder reserves the right to correct misprints in the manual without prior notice, and modify the exterior of the device for quality purposes without customer consent.



Charder Electronic Co., Ltd.  
No. 103, Guozhong Rd., Dali Dist.,  
Taichung City, 41262 Taiwan

# I. Safety Notes

## A. General Information

Thank you for choosing this Charder Medical device. It is designed to be easy and straightforward to operate, but if you encounter any problems not addressed in this manual, please contact your local Charder service partner.

Before beginning operation of the device, please read this user manual carefully, and keep it in a safe place for reference. It contains important instructions regarding installation, proper usage, and maintenance.

### **Intended Purpose**

This medical device is designed to be used in accordance with national regulations, to measure weight within specifications, for weight-related usage by professionals.

For the sake of consistency, "patient" will be used to refer to infants or toddlers for the rest of this document.

Patient is placed on a tray or sling which is attached to a weighing platform for the device to measure patient weight.

### **Clinical Benefit**

Measurement results can be used by professionals to diagnose (and monitor) weight-related issues.

### **Intended medical indications/contraindications**

Measurement: patient's body weight. No known contraindications to measurement of body weight.

### **Intended patient profile**

(a) Age: no restrictions (subject to size limitations of device)

and maximum capacity)

- (b) Weight: no restrictions within device weight capacity
- (c) Patient Conditions: require measurement of body weight.  
Can fit upon device.

### **Intended user profile**

- (a) At least 20 years old
- (b) Minimum knowledge:
  - To be able to read at a high-school level and understand Arabic numerals (e.g. 1, 2, 3, 4...)
  - Basic hygiene knowledge
  - Trained in device's operation
  - Read the instruction manual
- (c) Language
  - Able to read the language of instruction manual and on-screen instructions
- (d) Qualifications
  - No special certifications or qualifications required

### **Residual Risk Evaluation**

- (a) All foreseeable risks have been evaluated and considered acceptable. Generally speaking, the most likely risk caused by incorrect usage of the device is less accurate measurement (or inability to use device to acquire measurement), which does not pose imminent physical risk to patient or user.
- (b) Benefit-risk ratio is considered acceptable. Infant scales are an important option for measuring patients. Usage of device is unlikely to result in harm to user or patient.

### **General Handling**

- Ensure all parts are properly locked and tightened before operating the device.
- Measurement accuracy requires the subject's feet, back, and head to be straightly aligned. Please note that height can vary throughout the day



- **CAUTION:** Do not use next to equipment that may cause electromagnetic or other types of interference.

## **Safety Instructions**

Before putting device into use, please read this user manual carefully. It contains important instructions for installation, usage, and maintenance of device.

The manufacturer shall not be liable for damages caused by failure to heed the following instructions:

- The device has an expected service life of 5 years when correctly handled, serviced, and periodically inspected in accordance with manufacturer's instructions.
- Improper installation will render the warranty null and void.
- Observe permissible ambient temperatures for use

## **Maintenance**

Please contact your local Charder distributor for regular maintenance and calibration, regular checking of accuracy is recommended; frequency to be determined by level of use and state of device.

## **Cleaning**

Device surface should be cleaned using alcohol-based wipes.

## **Warranty/Liability**

- The period of warranty shall be eighteen(18) months, beginning on the date of purchase. Please retain your receipt as proof of purchase.
- No responsibility shall be accepted for damage caused through any of the following reasons: unsuitable or improper storage or use, incorrect installation or commissioning by the owner or third parties, natural

wear and tear, changes or modifications, incorrect or negligent handling, chemical, electrochemical, or electrical interference, unless damage is attributable to negligence on the part of Charder.

- This device does not contain any user-maintained parts. All maintenance, technical inspections, and repairs should be conducted by an authorized Charder service partner, using original Charder accessories and spare parts. Charder is not liable for any damages arising from improper maintenance or usage. Dismantlement of the device will void the warranty.

### **Incident Reporting**

Any serious incident that has occurred in relation to the device should be reported to the manufacturer, EU representative (if device is used in EU member state), and competent authority of user/subject's member state.

## B. EMC Guidance and Manufacturer's Declaration

<b>Guidance and manufacturer's declaration-electromagnetic emissions</b>		
<p>The product is intended for use in the electromagnetic environment specified below. The customer or the user of the product should assure that it is used in such an environment.</p>		
<b>Emission test</b>	<b>Compliance</b>	<b>Electromagnetic environment-guidance</b>
RF emissions CISPR 11	Group 1	The product uses RF energy only for its internal function. Therefore, its RF emissions are very low and are not likely to cause any interference in nearby electronic equipment.
RF emissions CISPR 11	Class A	The product is suitable for use in all establishments other than domestic and those directly connected to a low voltage power supply network which supplies buildings used for domestic purposes.
Harmonic emissions IEC 61000-3-2	Class A	
Voltage fluctuations /flicker emissions IEC 61000-3-3	Compliance	

## Guidance and manufacturer's declaration-electromagnetic immunity

The product is intended for use in the electromagnetic environment specified below. The customer or the user of the product should assure that it is used in such an environment.



Immunity test	IEC 60601 test level	Compliance level	Electromagnetic environment-guidance
Electrostatic discharge(ESD) IEC 61000-4-2	<u>± 8 kV contact</u> <u>± 2 kV, ± 4 kV, ± 8 kV, ± 15 kV air</u>	<u>± 8 kV contact</u> <u>± 2 kV, ± 4 kV, ± 8 kV, ± 15 kV air</u>	Floors should be wood, concrete or ceramic tile. If floors are covered with synthetic material, the relative humidity should be at least 30%
Electrical fast transient/burst IEC 61000-4-4	<u>± 2kV for power supply lines</u>	<u>± 2kV for power supply lines</u>	Mains power quality should be that of a typical commercial or hospital environment.
Surge IEC 61000-4-5	<u>± 1kV line(s) to line(s)</u> <u>± 2kV line(s) to earth</u>	<u>± 1kV line(s) to line(s)</u> <u>± 2kV line(s) to earth</u>	Mains power quality should be that of a typical commercial or hospital environment.
Voltage Dips, short interruptions and voltage variations on power supply input lines IEC 61000-4-11	<u>0% UT for 0.5 cycle</u> <u>0% UT for 1 cycle</u>  <u>70% UT(30% dip in UT) for 25cycles</u>  <u>0% UT for 5 s</u>	<u>0% UT for 0.5 cycle</u> <u>0% UT for 1 cycle</u>  <u>70% UT(30% dip in UT) for 25cycles</u>  <u>0% UT for 5 s</u>	Mains power quality should be that of a typical commercial or hospital environment. If the user of the product requires continued operation during power mains interruptions, it is recommended that the product be powered from an uninterruptible power supply or a battery.
Power frequency(50, 60 Hz) magnetic field IEC 61000-4-8	<u>30 A/m</u>	30 A/m	The product power frequency magnetic fields should be at levels characteristic of a typical location in a typical commercial or hospital environment.

NOTE UT is the a.c. mains voltage prior to application of the test level.

## Guidance and manufacturer's declaration-electromagnetic immunity

The product is intended for use in the electromagnetic environment specified below.

The customer or the user of the product should assure that is used in such and environment.

Immunity test	IEC 60601 test level	Compliance level	Electromagnetic environment-guidance
<p>Conducted RF IEC 61000-4-6</p>	<p>3 Vrms 150 KHz to 80 MHz</p> <p><u>6 V in ISM bands between 0,15 MHz and 80 MHz</u> <u>80 % AM at 1 kHz</u></p>	<p>3 Vrms 150 KHz to 80 MHz</p> <p><u>6 V in ISM bands between 0,15 MHz and 80 MHz</u> <u>80 % AM at 1 kHz</u></p>	<p>Portable and mobile RF communications equipment should be used no closer to any part of the product including cables, than the recommended separation distance calculated from the equation applicable to the frequency of the transmitter.</p> <p><b>Recommended separation distance:</b>  <math>d = 1,2 \sqrt{P}</math>  <math>d = 1,2 \sqrt{P}</math> 80MHz to 800 MHz  <math>d = 2,3 \sqrt{P}</math> 800MHz to 2,7GHz                      Where <math>P</math> is the maximum output power rating of the transmitter in watts (W) according to the transmitter manufacturer and <math>d</math> is the recommended separation distance in metres (m).</p> <p>Field strengths from fixed RF transmitters, as determined by an electromagnetic site survey, <sup>a</sup> should be less than the compliance level in each frequency range.<sup>b</sup></p> <p>Interference may occur in the vicinity of equipment marked with the following symbol:</p> <div style="text-align: center;">  </div>
<p>Radiated RF IEC 61000-4-3</p>	<p>3 V/m <u>80MHz to 2,7 GHz</u></p>	<p>3 V/m <u>80MHz to 2,7 GHz</u></p>	<p>Portable and mobile RF communications equipment should be used no closer to any part of the product including cables, than the recommended separation distance calculated from the equation applicable to the frequency of the transmitter.</p> <p><b>Recommended separation distance:</b>  <math>d = 1,2 \sqrt{P}</math>  <math>d = 1,2 \sqrt{P}</math> 80MHz to 800 MHz  <math>d = 2,3 \sqrt{P}</math> 800MHz to 2,7GHz                      Where <math>P</math> is the maximum output power rating of the transmitter in watts (W) according to the transmitter manufacturer and <math>d</math> is the recommended separation distance in metres (m).</p> <p>Field strengths from fixed RF transmitters, as determined by an electromagnetic site survey, <sup>a</sup> should be less than the compliance level in each frequency range.<sup>b</sup></p> <p>Interference may occur in the vicinity of equipment marked with the following symbol:</p> <div style="text-align: center;">  </div>

NOTE1 At 80 MHz and 800 MHz, the higher frequency range applies.

NOTE2

These guidelines may not apply in all situations. Electromagnetic propagation is affected by absorption and reflection from structures, objects and people.

- a Field strengths from fixed transmitters, such as base stations for radio (cellular/cordless) telephones and land mobile radios, amateur radio, AM and FM radio broadcast and TV broadcast cannot be predicted theoretically with accuracy. To assess the electromagnetic environment due to fixed RF transmitters, an electromagnetic site survey should be considered. If the measured field strength in the location in which the product is used exceeds the applicable RF compliance level above, the product should be observed to verify normal operation. If abnormal performance is observed, additional measures may be necessary, such as re-orienting or relocating the product.
- b Over the frequency range 150 kHz to 80 MHz, field strengths should be less than 3V/m.

**Recommended separation distance between portable and mobile RF communications equipment and the product**

The product is intended for use in an electromagnetic environment in which radiated RF disturbances are controlled. The customer or the user of the product can help prevent electromagnetic interference by maintaining a minimum distance between portable and mobile RF communications equipment (transmitters) and the product as recommended below, according to the maximum output power of the communications equipment.

Rated maximum output power of transmitter W	Separation distance according to frequency of transmitter m		
	150 kHz to 80 MHz $d = 1,2\sqrt{P}$	80 MHz to 800 MHz $d = 1,2\sqrt{P}$	<u>800 MHz to 2,7 GHz</u> $d = 2,3\sqrt{P}$
0,01	0,12	0,12	0,23
0,1	0,38	0,38	0,73
1	1,2	1,2	2,3
10	3,8	3,8	7,3
100	12	12	23

For transmitters rated at a maximum output power not listed above, the recommended separation distance d in metres (m) can be estimated using the equation applicable to the frequency of the transmitter, where p is the maximum output power rating of the transmitter in watts (W) according to the transmitter manufacturer.

NOTE1 At 80 MHz and 800 MHz, the separation distance for the higher frequency range applies.

NOTE2 These guidelines may not apply in all situations. Electromagnetic propagation is affected by absorption and reflection from structures, objects and people.

## II. Installation

### A. Height Measure Attachment

1. Attach bracket to device, and fasten screws using screwdriver.

Version with rubber head pad

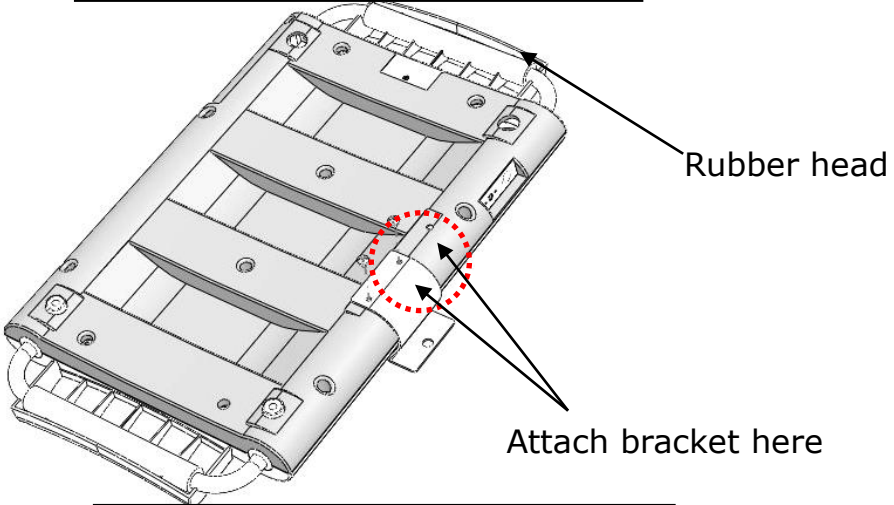

Version without rubber head pad

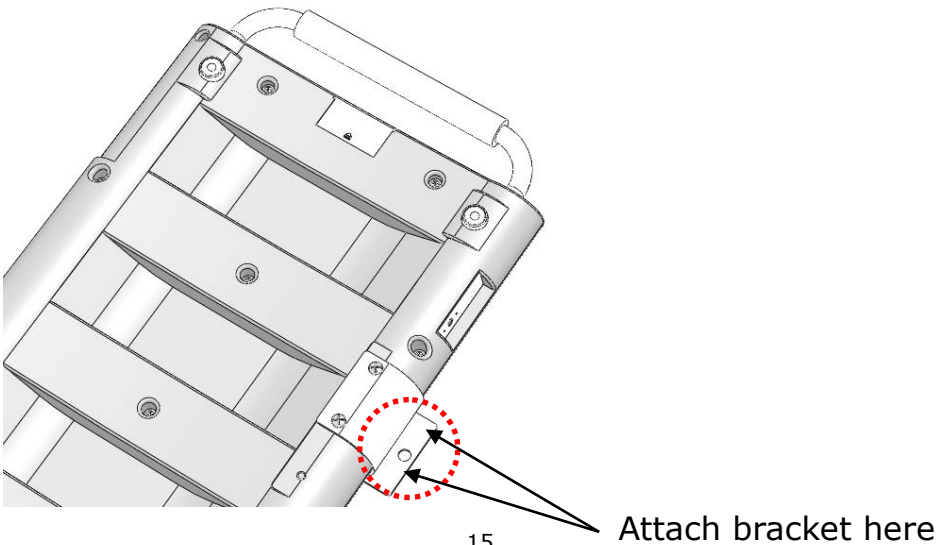

2 · Connect height measure attachment (HM80D or HM80M) to bracket. A clicking noise will be heard.

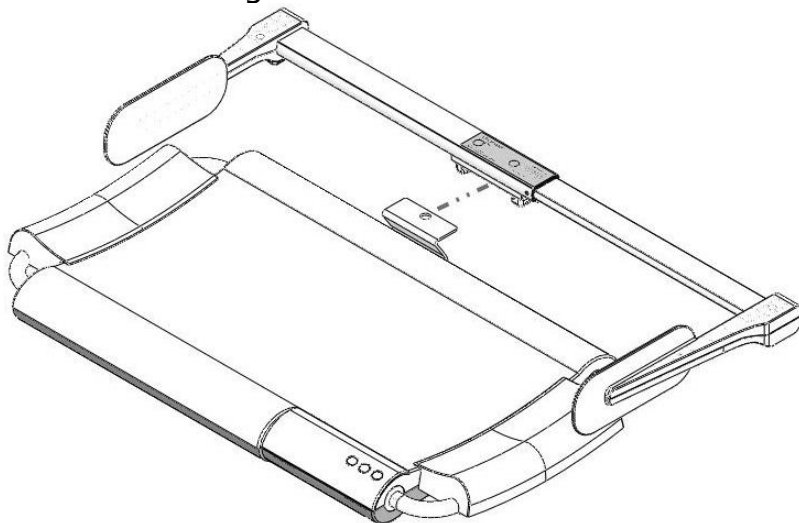

3 · To detach height measure, find the latch located at the rear of the attachment. Press down on the buckle, and gently remove the attachment from bracket.

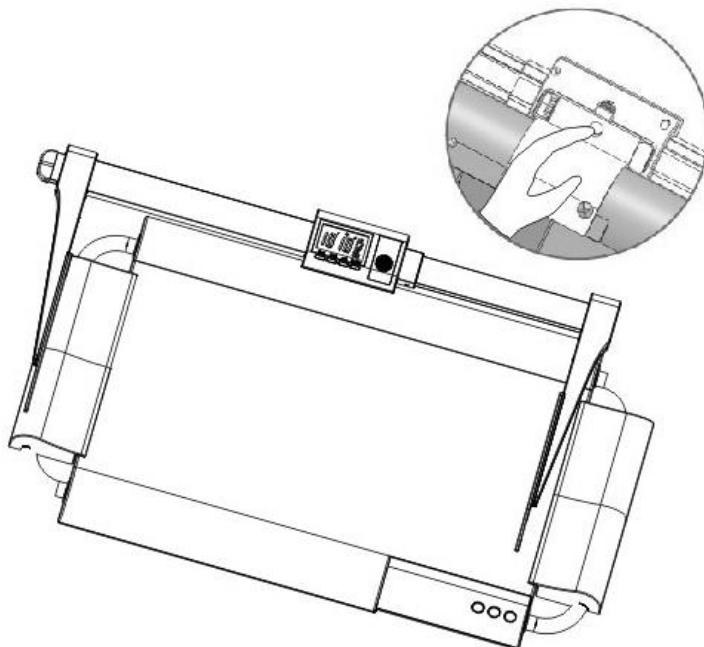



## B. Inserting Batteries

1. Locate battery cover

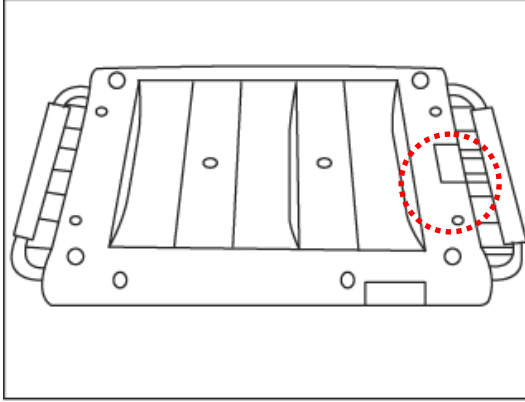

2. Remove battery cover

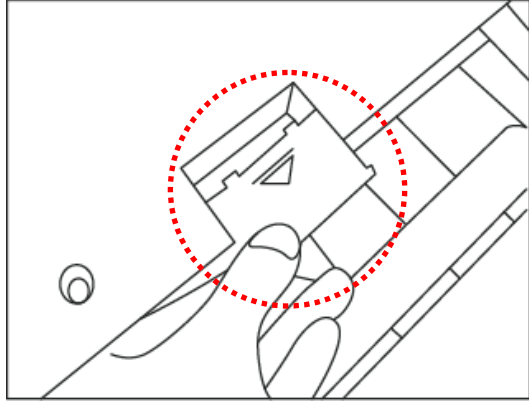

3. Insert 9V battery

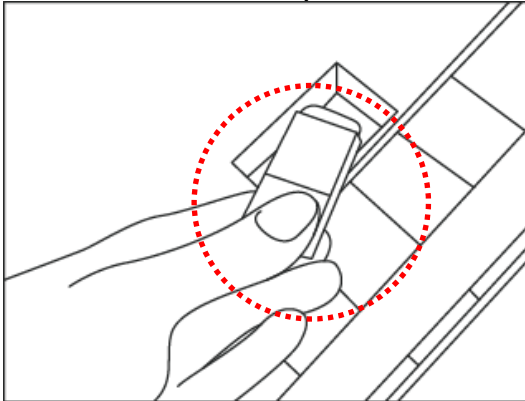

4. Put the battery cover back

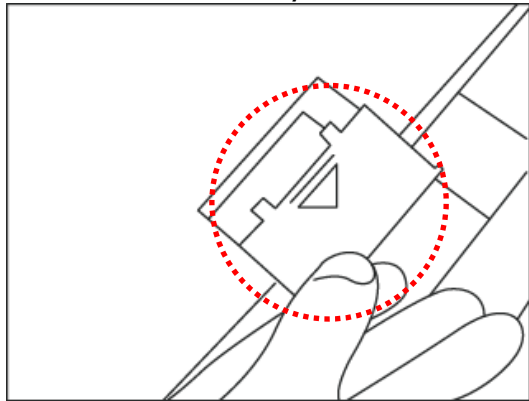

## C. Using AC Adapter

Device can be powered using AC adapter located at rear of device. Plug adapter into device before plugging into mains.

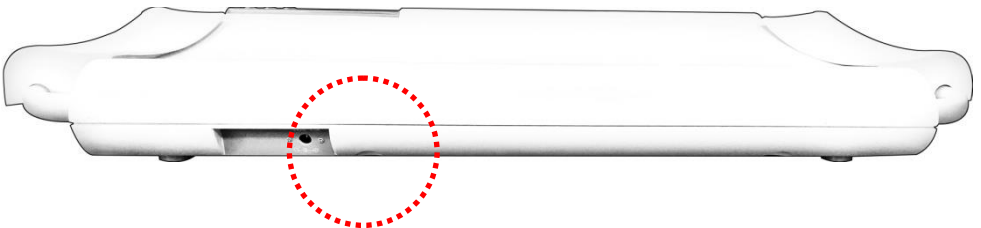

## III. Indicator

### A. Indicator and Key Functions

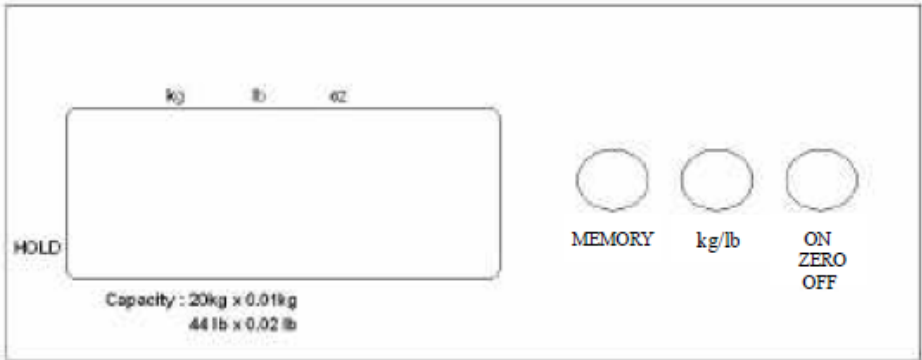

### B. Key Functions

1. **MEMORY**: Recall and release weight stored in memory
2. **kg/lb**: Press this key to switch unit between kg, lb, oz, and lb: oz.
3. **ON/ZERO/OFF**: When device is off, press to power on. When device is on, press to zero weight (under 2% of max capacity). Press and hold to turn device off.

## IV. Using Device

### A. Basic Operation

Switch on the device using **[ON/ZERO/OFF]** key. The device will automatically perform self-calibration, displaying software version.

Once "0.00 kg" appears on indicator, device is ready for measurement.

**Note:** If "0.00 kg" does not display on indicator, press **[ZERO]** key to zero the device.

Carefully place subject upon the measurement platform. After the weight has stabilized, the "stable" symbol will appear on indicator.

**Note:** If subject's weight exceeds scale capacity (including tare), indicator will display "Err" prompt due to overload.

### B. Tare

The tare function allows the user to deduct the weight of objects from the device's measurement result. Tare can be used when weight of object is  $\geq 400\text{g}$  (at/above 2% of full 20 kg capacity).

1. Place object that needs to be tared onto measurement platform.
2. Press **[TARE]** key after stable symbol appears on indicator. Display will indicate "0.00 kg".
3. Place subject (plus tared object) to be weighed upon measurement platform. Conduct measurement.
4. To clear tare value, remove all objects from measurement platform, and press **[TARE]** key.

### **C. Recall**

Weight value can be stored (>1 kg) and recalled. If weight on platform is greater than 1 kg, press **[RECALL]** key to store weight value. If weight on platform is less than 1 kg, press **[RECALL]** key to recall stored weight value.

To return to normal weighing mode, press **[ON/ZERO/OFF]** key.

# V. Device Setup

When the device is switched on, press and hold the [TARE] key until the display shows "SET" followed by "A.OFF" (first option in setting menu).

In device setup:  
[TARE] to toggle menu option  
[RECALL] to confirm selection / enter submenu

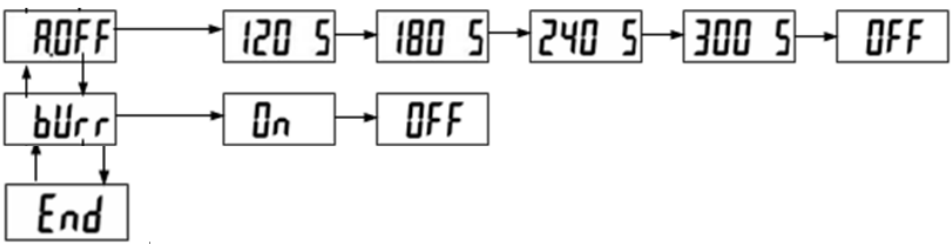

## A OFF

**Auto Power-Off:**Instruct device to shut off automatically after a certain period of time.

Auto off options: 120 sec / 180 sec / 240 sec / 300 sec / off  
Press [TARE]to toggle between time options, and [RECALL] to confirm selection.

## bUrr

### Buzzer/Beep:

When function is turned on, beeping noise will be made when: indicator is turned on, keys are pressed, and weight is stable.

Press [TARE] to toggle between on/off, and [RECALL] key to confirm selection.



**Bluetooth (optional):** If device has Bluetooth module installed, Bluetooth function can be turned on or off. Press **[TARE]** to toggle between on/off, and **[RECALL]** key to confirm selection.



**Wi-Fi Setting (optional):** If device has Wi-Fi module installed, Wi-Fi function can be turned on or off. Press **[TARE]** to toggle between on/off, and **[RECALL]** key to confirm selection.

If "Auto" is selected, weight measurement will be automatically sent to connected printer or device. If "PKEY" is selected, transfer will occur manually after command.

## VI. Troubleshooting

### Product Defects

Charder's warranty is effective for the original purchaser of this device, subject to the terms and conditions listed in the Warranty Program & Return Policy.

1. If Charder is responsible for a fault or defect present upon receipt of the unit, Charder shall either repair the fault, or supply a replacement unit. Should the repairs or replacement delivery fail, statutory provisions shall be valid. The period of warranty shall be two years, beginning on the date of purchase. Please retain your receipt as proof of purchase.
2. No responsibility shall be accepted for damage caused through any of the following reasons: unsuitable or improper storage or use, incorrect installation or commissioning by the owner or third parties, natural wear and tear, changes or modifications, incorrect or negligent handling, chemical, electrochemical, or electrical interference, unless damage is attributable to negligence on the part of Charder.

If device is not covered under warranty, a service maintenance charge will apply, plus cost of replacement parts.

Before contacting your local Charder distributor for repair service, we recommend considering the following troubleshooting procedures:

### Self-inspection

Weight value can be stored (>1 kg) and recalled. If weight on platform is greater than 1 kg, press **[RECALL]** key to store weight value. If weight on platform is less than 1 kg, press **[RECALL]** key to recall stored weight value.

## **1. Device will not power on**

- If battery power is depleted, replace with new batteries.
- If batteries are not used, check if the power adapter is plugged into the device properly. Check if power adapter is plugged into mains properly.

## **2. Indicator showing "00000" ZERO SPAN out of range**

- Interference due to factors such as RF disturbance or ground vibration. Relocate device to location without interference and try again.
- Unstable platform. Relocate device to stable location and try again.
- External objects interfering with measurement platform. Clear platform of objects and try again.
- Device may not function properly on soft surfaces such as carpets or lawns. Relocate device to location with solid, stable floor.
- If the steps above cannot resolve the problem, re-calibration may be required to correct weighing accuracy.

## **Distributor support required**

If the following errors occur, we recommend contacting your local Charder distributor for repair or replacement services:

### **1. Device will not power on**





- Faulty on/off key
- Broken or damaged wires causing short circuit or faulty connection
- Safety fuse burnout
- Faulty adapter



## 2. Indicator damage

- Possible hardware defects include: uneven brightness in LCD screen, blurred text, smeared rainbow screen, incorrect decimal display
- Unable to save or read data
- Indicator shows "**ERRL**" after device is switched on
- Keys not responding
- Buzzer malfunction

## Error Messages

Error Message	Reason	Action
	<b>Low battery warning</b> Voltage of battery is too low to operate device	Replace batteries, or plug in AC adapter
	<b>Overload</b> Total load exceeds device's maximum capacity	Reduce weight on measurement platform and try again
	<b>Over Zero</b> Zero count is higher than setting range. Device will turn off automatically in 30 seconds if status continues	Error normally caused by faulty loadcell or wiring. Please contact distributor
	<b>Under Zero</b> Zero count is lower than setting range. Device will turn off automatically in 30 seconds if status continues.	Error normally caused by faulty loadcell or wiring. Please contact distributor

## VII. Product Specifications

### A. Device Information

<b>Model</b>		<b>MS2400</b>
<b>Weight Measurement</b>	<b>Capacity</b>	20kg x 10g
	<b>Accuracy</b>	±20g
	<b>LCD Screen</b>	1.0-inch LCD screen (4 1/2 digits)
<b>Dimensions</b>	<b>Device plus Handle</b>	640(W) x 355(D) x 60(H) mm
	<b>Platform Surface</b>	500(W) x 350(D) mm
<b>Device Weight</b>		2.8 kg
<b>Key Functions</b>		On/Zero/Off, Tare, Recall
<b>Data Transmission</b>		N/A
<b>Power Supply</b>		9V battery / Power adapter
<b>Operation Environment</b>		+5°C~+35°C 5% / 85%RH 700 hPa ~1060 hPa
<b>Standard Accessories</b>		User manual*1 Power adapter*1
<b>Optional Accessories</b>		Carrying bag

## B. Power Adapter Standards

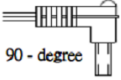

### **Warning**

The device is only compatible with the manufacturer's power adapters specified below

<b>AMP VOLTAGE</b>	<b>DRAWING NO.</b>	<b>CE APPROVED TYPE NO. / MODEL NO.</b>	<b>TYPE</b>	<b>Adapter plug</b>
12V 0.5A	CD-AD-00011	UES06WOCPC-1200 50SPA	US	
			EU	
			UK	
			AU	

## VIII. Declaration of Conformity

This product has been manufactured in accordance with the harmonized European standards, following the provisions of the below stated directives:

	<b>(EU) 2017/745 Regulation on Medical Devices</b>
	<b>2014/31/EU Non-automatic Weighing Instruments Directive (OIML models only)</b>

**RoHS Directive 2011/65/EU and Delegated Directive (EU) 2015/863**

**Radio Equipment Directive 2014/53/EU**

(applicable if wireless module is used)

### Part 15 of the Federal Communications Statement Rules

This device may not cause harmful interference.

This device must accept any interference received, including interference that may cause undesired operation.

*Please see separate document showing on sticker of device for above markings.*

Authorized EU Representative:



**Obelis s.a.**

Bd Général Wahis, 53  
B-1030 Brussels  
Belgium

**Manufactured by:**



Charder Electronic Co., Ltd.  
No.103, Guozhong Rd., Dali Dist.,  
Taichung City 41262 ,Taiwan

CD-IN-0987 7010V 08/2024