



Body Composition Analyzer

USER MANUAL

MBF6000 / MBF6010

Body Composition Analyzer

























Please keep the instruction manual at hand and follow instructions for use.

CONTENTS

I. Explanation of Graphic Symbols on Label/Packaging	3
II. Copyright Notice	5
III. Safety Notes	6
A. General Information	6
B. EMC Guidance and Manufacturer's Declaration	10
IV. Installation	14
A. Assembly (MBF6010 only)	14
B. Inserting Batteries	15
C. Using Adapter	16
C. Using Rechargeable Battery (optional)	16
D. Attaching Height Stadiometer to MBF6010 Column	17
E. Attaching Thermal Printer to MBF6010 Column	19
V. Exterior and Panel	21
A. Quick Guide to components	21
B. Indicator and Key Functions	22
C. Display layout	23
VI. Using Device	24
A. Setup Device for Measurement	24
B. Pre-Tare	25
C. Conduct Measurement	26
D. Print	27
E. Measurement Results Explained	28
F. About Bioelectrical Impedance Measurement	31
VII. Device Setup	33
A. Setting Time & Date	33
B. Device Setup	34
VIII. Connecting scale to receiving device	36
IX. Troubleshooting	36
X. Product Specifications	39
A. Device Information	39
B. Output Items (Display and Print-out)	40
C. Power Adapter Standards	41
XI. Declaration of Conformity	42

I. Explanation of Graphic Symbols on Label/Packaging

Text/Symbol	Meaning
	Caution. Failure to follow instructions may result in adverse events
	Separate collection for waste of electrical and electronic equipment, in accordance with Directive 2002/96/EC. Do not dispose of device with everyday waste
	Name and address of device manufacturer
	Carefully read user manual before installation and usage, and follow instructions for use.
	Medical electrical device, Type B applied part
	Device catalogue number
	Name and address of authorized representative in the European Union (applicable for medical devices only)
	Device is a medical device. Text indicates device category type
	Manufacturer's batch or lot number for device
	Device's serial number
	Device's model number
	Device's Unique Device Identifier (01) GTIN (11) Production date (21) Serial number
	Value in mass units. This is the difference between two consecutive display values, used to classify and verify a scale
	Device conforms to (EU) 2017/745 Regulation on Medical Devices. Four digit number is identifier for medical device Notified Body
	Device claims conformity with essential regulations set by the relevant European Union legislation
	Device complies with EU directives M : Conformity label in compliance with Directive 2014/31/EU for non-automatic weighing instruments 17 : Year in which conformity verification was performed and the CE label was applied. (ex: 17=2017) 0122 : Identifier for metrology Notified Body
	Device is a Class III scale in compliance with Directive 2014/31/EU
	Name and address of entity importing device
	Name and address of entity responsible for translating Information For Use

CON.	Event counter recording how many times protected-mode parameter adjustments relating to metrology-related characteristics (ex: gravity value) have been conducted for device
	Device has received Taiwan NCC approval
	Device conforms to U.S. Federal Communications Commission regulations
	Device complies with all UK applicable product legislation
	Device's polarity of power.

In case of differences, icon on device itself takes precedence

II. Copyright Notice

Copyright Notice

Charder Electronic Co., Ltd.

No.103, Guozhong Rd., Dali Dist., Taichung City 41262 Taiwan

Tel: +886-4-2406 3766

Fax: +886-4-2406 5612

Website: www.chardermedical.com

E-mail: info_cec@charder.com.tw

Copyright© Charder Electronic Co., Ltd. All rights reserved.

This user manual is protected by international copyright law. All content is licensed, and usage is subject to written authorization from Charder Electronic Co., Ltd. (hereinafter Charder) Charder is not liable for any damage caused by a failure to adhere to requirements stated in this manual. Charder reserves the right to correct misprints in the manual without prior notice, and modify the exterior of the device for quality purposes without customer consent.



Charder Electronic Co., Ltd.
No. 103, Guozhong Rd., Dali Dist.,
Taichung City, 41262 Taiwan

III. Safety Notes

A.General Information

Thank you for choosing this Charder Medical device. It is designed to be easy and straightforward to operate, but if you encounter any problems not addressed in this manual, please contact your local Charder service partner.

Before beginning operation of the device, please read this user manual carefully, and keep it in a safe place for reference. It contains important instructions regarding installation, proper usage, and maintenance.

Intended Purpose

This medical device is designed to estimate body composition in professional settings in accordance with national regulations. The device measures the patient's weight and bioelectrical impedance measurements using foot touch electrodes, combining them with input data (ex: age, gender, height) to estimate:

Body Fat Percentage (BF %), Fat-Free Mass (FFM), Fat Mass (FM), Bone Mineral (BM), Muscle Mass (MM), Basal Metabolic Rate (BMR), Total Body Water (TBW), Protein Mass (PM), Intracellular Water (ICW), Extracellular Water (ECW), Skeletal Muscle (SM), Health Score, Visceral Fat Area Level (VFALEVEL), Metabolic Age (AGEM)

The device is not a diagnostic device. Results should be used as part of a broader comprehensive assessment.

Clinical Benefit

The device is used for body measurement/estimation. The measurement results can be used in such a wide variety of applications that it may not be practical or beneficial to narrowly define the associated clinical benefits of receiving such results. Therefore, the benefit of the device is that it is able to perform its intended (measurement/estimation) function. A list of potential applications for key measurement outputs includes but is not limited to:

Result Category	Example Application
Fat	Obesity: evaluating risk of obesity-related diseases
Water	Peritoneal Dialysis: assessment of change in water balance before and after treatment
Muscle	Sarcopenia: evaluating muscle mass and effectiveness to identify malnutrition or training/rehabilitation needs
Metabolism	Nutrition: determining suitable level of daily caloric consumption based on goals and projected expenditure

Intended medical indications/contraindications

Measurement: patient's body composition and body weight.

Contraindications

Measurement should not be conducted on patients with electronic medical implants (ex: cardiac pacemakers)

Intended patient profile

- (a) Age: 10-80
- (b) Weight: within 300 kg
- (c) Patient Conditions: require measurement of body weight and body composition. Able to stand independently without support.

Intended user profile

- (a) At least 20 years old
- (b) Minimum knowledge:
 - To be able to read at a high-school level and understand Arabic numerals (e.g. 1, 2, 3, 4...)
 - Basic hygiene knowledge
 - Trained in device's operation
 - Read the instruction manual
- (c) Language
 - Able to read the language of instruction manual and on-screen instructions
- (d) Qualifications
 - No special certifications or qualifications required

Residual Risk Evaluation

- (a) All foreseeable risks have been evaluated and considered acceptable. Generally speaking, the most likely risk caused by incorrect usage of the device is less accurate measurement (or inability to use device to acquire measurement), which does not pose imminent physical risk to patient or user.
- (b) Benefit-risk ratio is considered acceptable. Body composition analyzers are an important option for measuring patients. Usage of device is unlikely to result in harm to user or patient.

General Handling

- Ensure all parts are properly locked and tightened before operating the device.
- Measurement accuracy requires the subject's feet, back, and head to be straightly aligned. Please note that height can vary throughout the day
- **CAUTION:** Do not use next to equipment that may cause electromagnetic or other types of interference.

Safety Instructions

Before putting device into use, please read this user manual carefully. It contains important instructions for installation, usage, and maintenance of device.

The manufacturer shall not be liable for damages caused by failure to heed the following instructions:

- The device has an expected service life of 5 years when correctly handled, serviced, and periodically inspected in accordance with manufacturer's instructions.
- Improper installation will render the warranty null and void.
- Observe permissible ambient temperatures for use

Cleaning

Device surface should be cleaned using alcohol-based wipes.

Maintenance

Please contact your local Charder distributor for regular maintenance and calibration, regular checking of accuracy is recommended; frequency to be determined by level of use and state of device.

Warranty/Liability

- The period of warranty shall be eighteen(18) months, beginning on the date of purchase. Please retain your receipt as proof of purchase.
- No responsibility shall be accepted for damage caused through any of the following reasons: unsuitable or improper storage or use, incorrect installation or commissioning by the owner or third parties, natural wear and tear, changes or modifications, incorrect or negligent handling, chemical, electrochemical, or electrical interference, unless damage is attributable to negligence on the part of Charder.
- This device does not contain any user-maintained parts. All maintenance, technical inspections, and repairs should be conducted by an authorized Charder service partner, using original Charder accessories and spare parts. Charder is not liable for any damages arising from improper maintenance or usage. Dismantlement of the device will void the warranty.

Incident Reporting

Any serious incident that has occurred in relation to the device should be reported to the manufacturer, EU representative (if device is used in EU member state), and competent authority of user/subject's member state.

B. EMC Guidance and Manufacturer's Declaration

Guidance and manufacturer's declaration-electromagnetic emissions		
<p>The device is intended for use in the electromagnetic environment specified below. The customer or the user of the product should assure that it is used in such an environment.</p>		
Emission test	Compliance	Electromagnetic environment-guidance
RF emissions CISPR 11	Group 1	The product uses RF energy only for its internal function. Therefore, its RF emissions are very low and are not likely to cause any interference in nearby electronic equipment.
RF emissions CISPR 11	Class A	The product is suitable for use in all establishments other than domestic and those directly connected to a low voltage power supply network which supplies buildings used for domestic purposes.
Harmonic emissions IEC 61000-3-2	Class A	
Voltage fluctuations /flicker emissions IEC 61000-3-3	Compliance	

Guidance and manufacturer's declaration-electromagnetic immunity			
<p>The device is intended for use in the electromagnetic environment specified below. The customer or the user of the product should assure that it is used in such an environment.</p>			
Immunity test	IEC 60601 test level	Compliance level	Electromagnetic environment-guidance
Electrostatic discharge(ESD) IEC 61000-4-2	± 8 kV contact ± 2 kV, ± 4 kV, ± 8 kV, ± 15 kV air	± 8 kV contact ± 2 kV, ± 4 kV, ± 8 kV, ± 15 kV air	Floors should be wood, concrete or ceramic tile. If floors are covered with synthetic material, the relative humidity should be at least 30%
Electrical fast transient/burst IEC 61000-4-4	± 2 kV for power supply lines	± 2 kV for power supply lines	Mains power quality should be that of a typical commercial or hospital environment.

Surge IEC 61000-4-5	± 1kV line(s) to line(s) ± 2kV line(s) to earth	± 1kV line(s) to line(s) ± 2kV line(s) to earth	Mains power quality should be that of a typical commercial or hospital environment.
Voltage Dips, short interruptions and voltage variations on power supply input lines IEC 61000-4-11	0% UT for 0,5 cycle 0% UT for 1 cycle 70% UT(30% dip in UT) for 25cycles 0% UT for 5 s	0% UT for 0,5 cycle 0% UT for 1 cycle 70% UT(30% dip in UT) for 25cycles 0% UT for 5 s	Mains power quality should be that of a typical commercial or hospital environment. If the user of the product requires continued operation during power mains interruptions, it is recommended that the product be powered from an uninterruptible power supply or a battery.
Power frequency(50, 60 Hz) magnetic field IEC 61000-4-8	30 A/m	30 A/m	The product power frequency magnetic fields should be at levels characteristic of a typical location in a typical commercial or hospital environment.
NOTE UT is the a.c. mains voltage prior to application of the test level.			

Guidance and manufacturer's declaration-electromagnetic immunity

The device is intended for use in the electromagnetic environment specified below.

The customer or the user of the product should assure that it is used in such an environment.

Immunity test	IEC 60601 test level	Compliance level	Electromagnetic environment-guidance
Conducted RF IEC 61000-4-6	3 Vrms 150 KHz to 80 MHz <u>6 V in ISM bands between 0,15 MHz and 80 MHz</u> 80 % AM at 1 kHz	3 Vrms 150 KHz to 80 MHz <u>6 V in ISM bands between 0,15 MHz and 80 MHz</u> 80 % AM at 1 kHz	Portable and mobile RF communications equipment should be used no closer to any part of the product including cables, than the recommended separation distance calculated from the equation applicable to the frequency of the transmitter. Recommended separation distance: $d = 1,2 \sqrt{P}$ $d = 2,3 \sqrt{P}$ 80MHz to 800 MHz Where P is the maximum output power rating of the transmitter in watts (W) according to the transmitter manufacturer and d is the recommended separation distance in metres (m).
Radiated RF IEC 61000-4-3	3 V/m <u>80MHz to 2,7 GHz</u>	3 V/m <u>80MHz to 2,7 GHz</u>	

Field strengths from fixed RF transmitters, as determined by an electromagnetic site survey, ^a should be less than the compliance level in each frequency range.^b

Interference may occur in the vicinity of equipment marked with the following symbol:



NOTE1 At 80 MHz and 800 MHz, the higher frequency range applies.

NOTE2 These guidelines may not apply in all situations. Electromagnetic propagation is affected by absorption and reflection from structures, objects and people.

a Field strengths from fixed transmitters, such as base stations for radio (cellular/cordless) telephones and land mobile radios, amateur radio, AM and FM radio broadcast and TV broadcast cannot be predicted theoretically with accuracy. To assess the electromagnetic environment due to fixed RF transmitters, an electromagnetic site survey should be considered. If the measured field strength in the location in which the product is used exceeds the applicable RF compliance level above, the product should be observed to verify normal operation. If abnormal performance is observed, additional measures may be necessary, such as re-orienting or relocating the product.

b Over the frequency range 150 kHz to 80 MHz, field strengths should be less than 3V/m.

Recommended separation distance between portable and mobile RF communications equipment and the device

The device is intended for use in an electromagnetic environment in which radiated RF disturbances are controlled. The customer or the user of the product can help prevent electromagnetic interference by maintaining a minimum distance between portable and mobile RF communications equipment (transmitters) and the product as recommended below, according to the maximum output power of the communications equipment.

Rated maximum output power of transmitter W	Separation distance according to frequency of transmitter m		
	150 kHz to 80 MHz $d = 1,2\sqrt{P}$	80 MHz to 800 MHz $d = 1,2\sqrt{P}$	<u>800 MHz to 2,7 GHz</u> $d = 2,3\sqrt{P}$
0,01	0,12	0,12	0,23
0,1	0,38	0,38	0,73
1	1,2	1,2	2,3

10	3,8	3,8	7,3
100	12	12	23

For transmitters rated at a maximum output power not listed above, the recommended separation distance d in metres (m) can be estimated using the equation applicable to the frequency of the transmitter, where p is the maximum output power rating of the transmitter in watts (W) according to the transmitter manufacturer.

NOTE1 At 80 MHz and 800 MHz, the separation distance for the higher frequency range applies.

NOTE2 These guidelines may not apply in all situations. Electromagnetic propagation is affected by absorption and reflection from structures, objects and people.

IV. Installation

A. Assembly (MBF6010 only)

1. Remove base and column from box

NOTE: remove entire device (column + platform) from box at the same time. Do not lift column by itself, as this may damage wire connecting measurement platform to indicator.

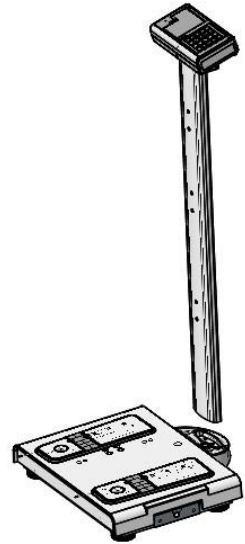

2. Fasten and tighten four screws at the bottom of the base

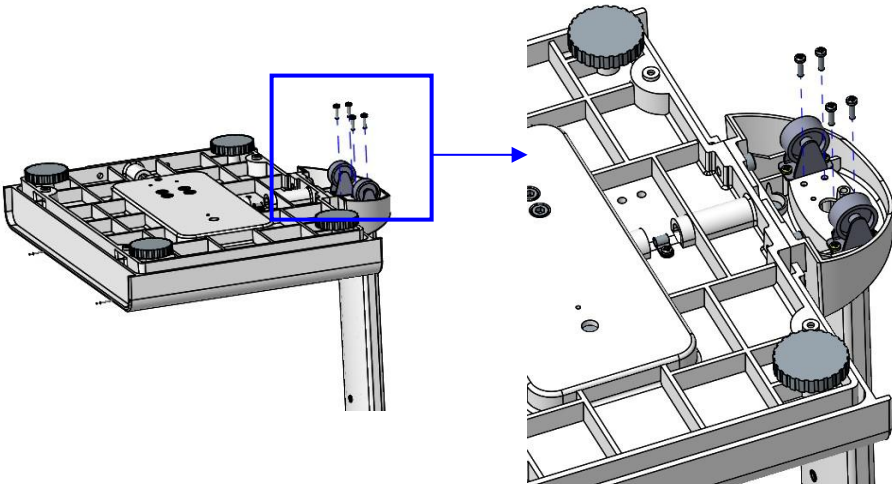

B. Inserting Batteries

1. Open battery housing cover

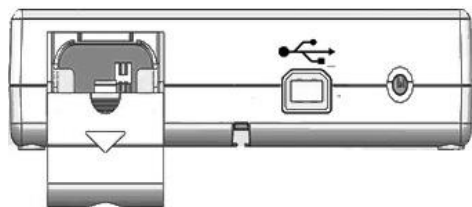

2. Push down tab securing battery housing



3. Remove battery housing

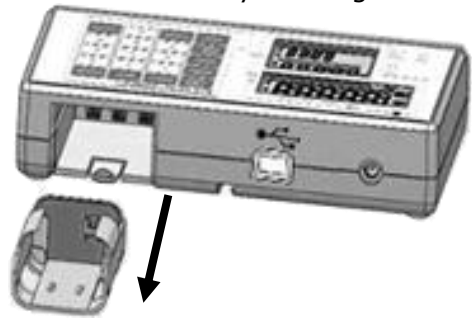

4. Insert battery pack

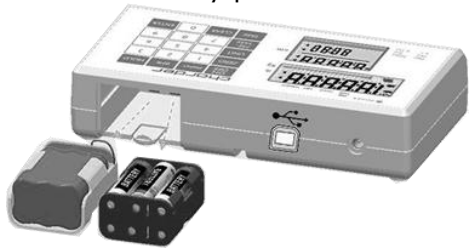

NOTE: Ensure that batteries are installed into housing correctly

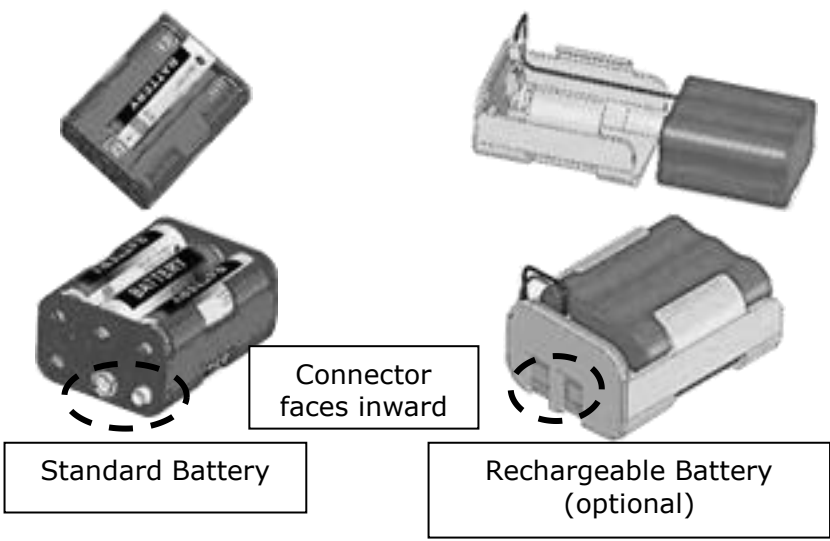

5. Slide battery housing cover back in place. Turn on power to confirm that battery is correctly installed.

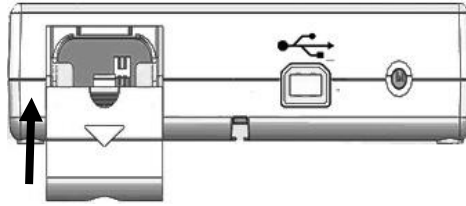

C. Using Adapter

1. Connect adapter to indicator before connecting to mains power supply
2. Disconnect adapter from mains power supply before unplugging adapter pin from indicator.

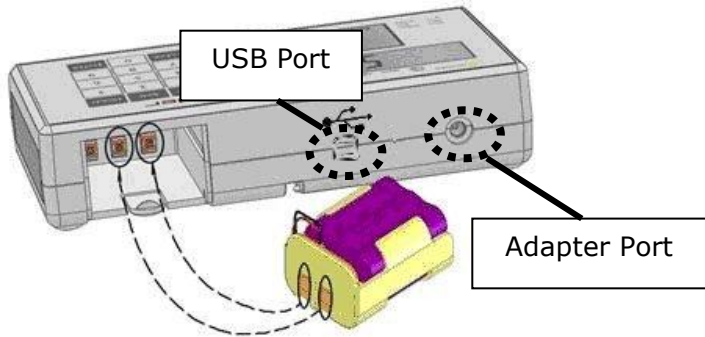

C. Using Rechargeable Battery (optional)

To charge the rechargeable battery, plug in the device's power adapter.

The rechargeable battery should be recharged at least once every 3 months, regardless of if the device has been used.

After a long period in storage (e.g. >3 months), the battery should run a full cycle (charge/discharge) to allow it to restore full capacity.

If Lo prompt displays on the LCD, please charge battery promptly to avoid battery damage.

D. Attaching Height Stadiometer to MBF6010 Column

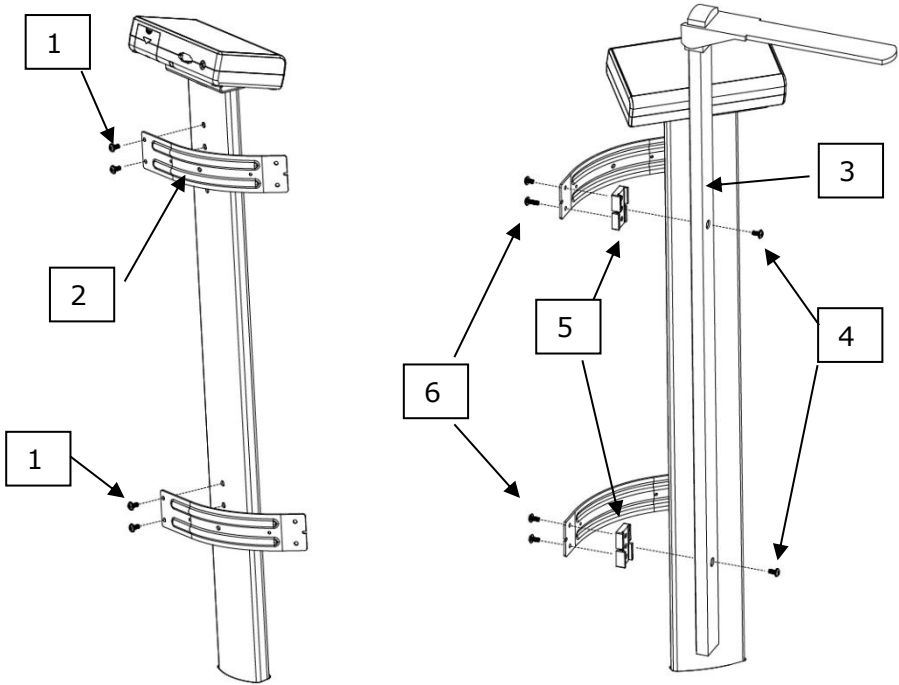

1. Attach brackets to column with round-head screws

2. Attach height rod to brackets using flat-head screws

Item	Name	Quantity
1	M5x0.8x11 round head screw	4
2	Bracket for HM200D/HM201D/HM201M	2
3	Height Rod (Compatible with: HM200D/HM201D/HM201M)	1
4	M5x10L flat head screw	2
5	Fixing block	2
6	M5x0.8x11	4

Connecting Digital Height Stadiometer to Indicator (HM200D/HM201D)

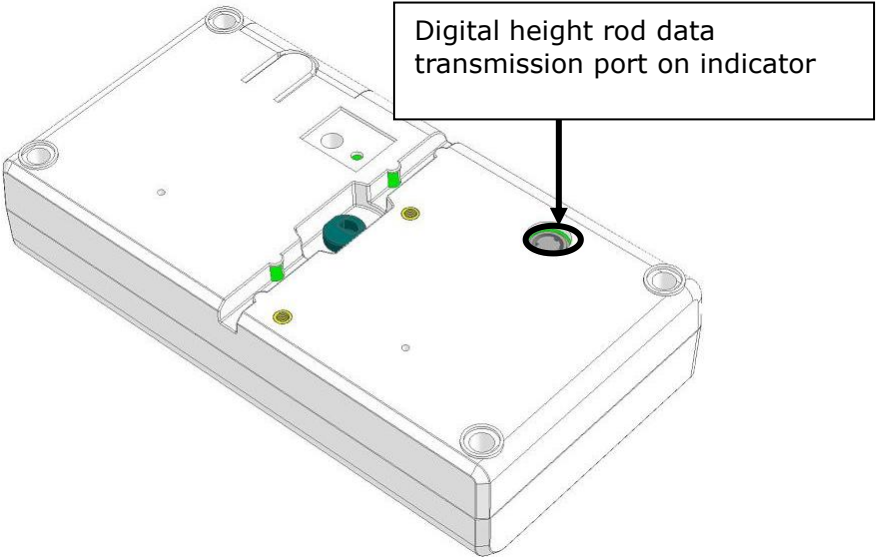
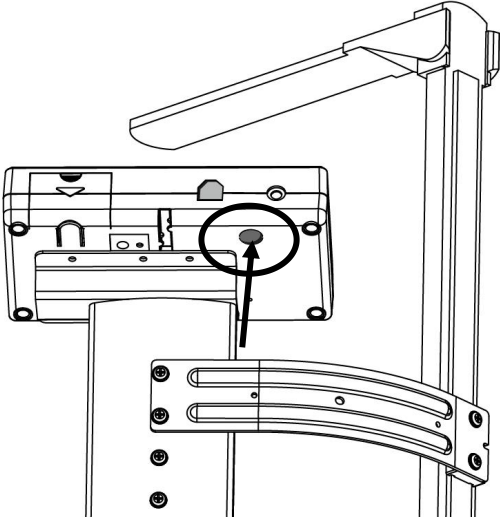

E. Attaching Thermal Printer to MBF6010 Column

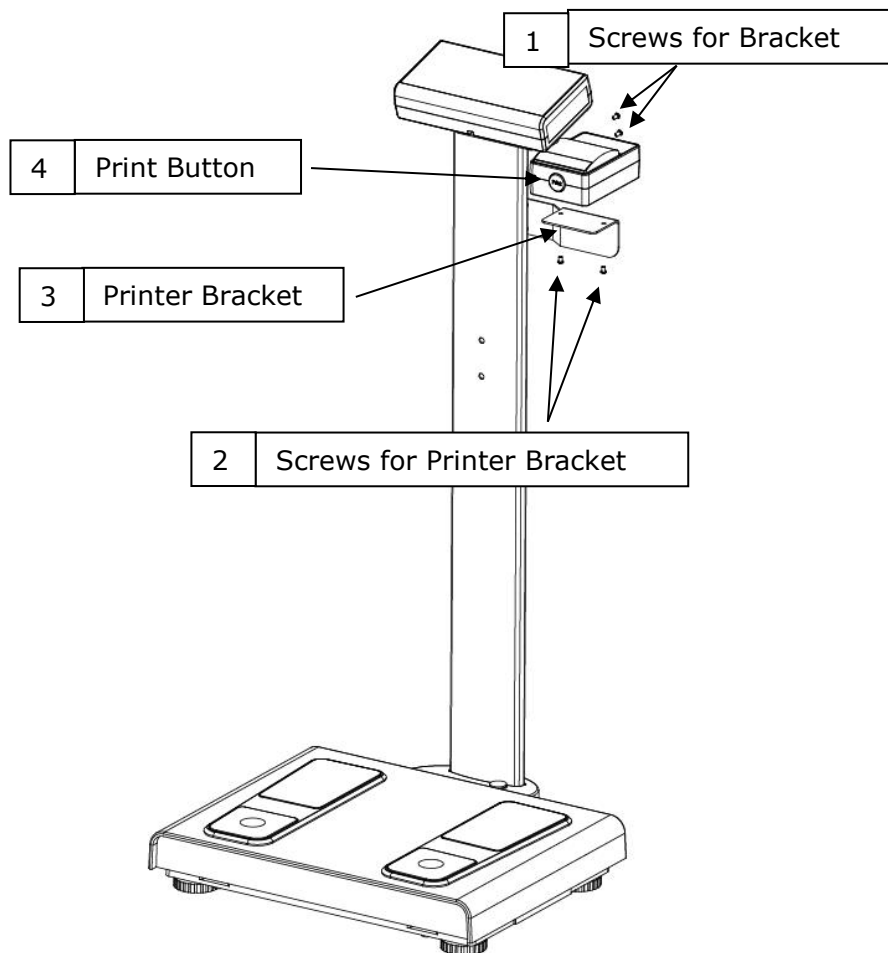

Item	Parts	Qty
1	M5*15L head screw	2
2	M4*6 Screws for printer bracket	2
3	Printer bracket	1
4	TP2100/TP2110 Thermal Printer	1 (purchased separately)

1. Install the side bracket

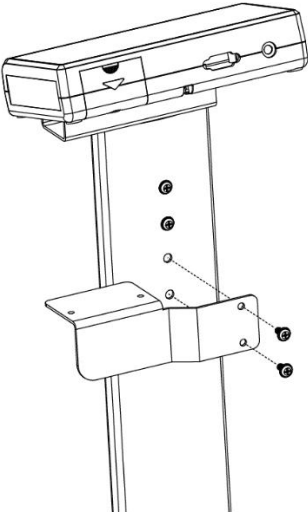

2. Install the thermal printer on the bracket

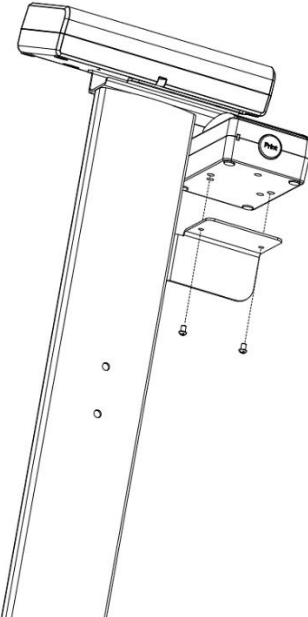

V. Exterior and Panel

A. Quick Guide to components

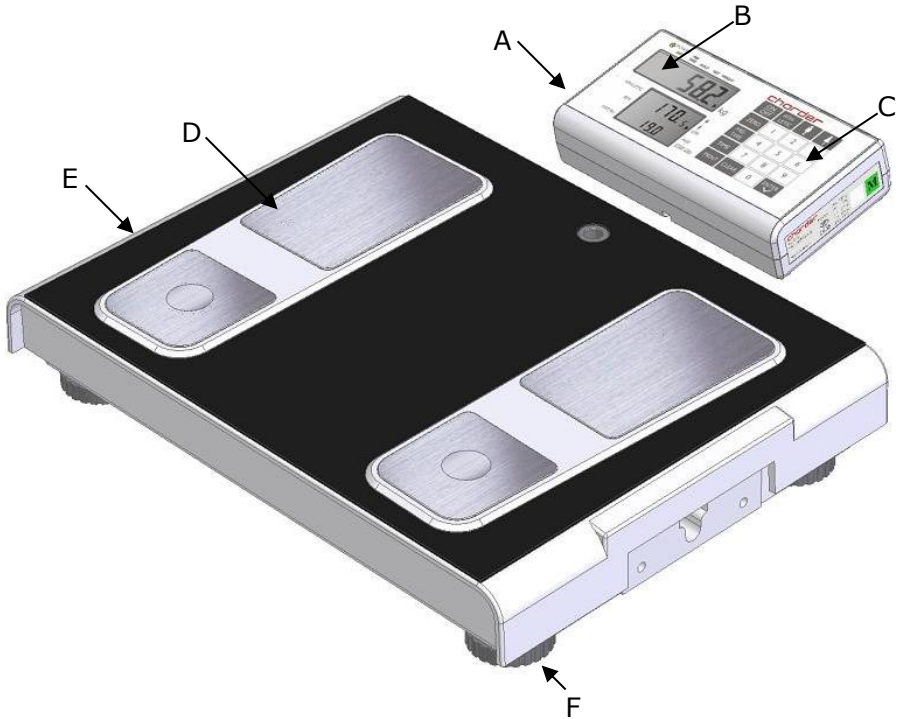



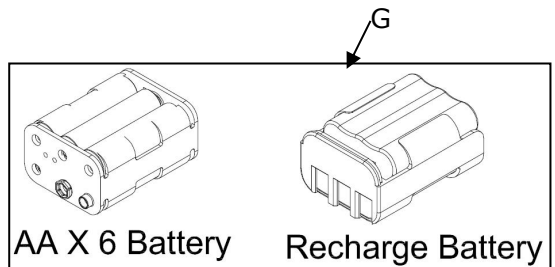



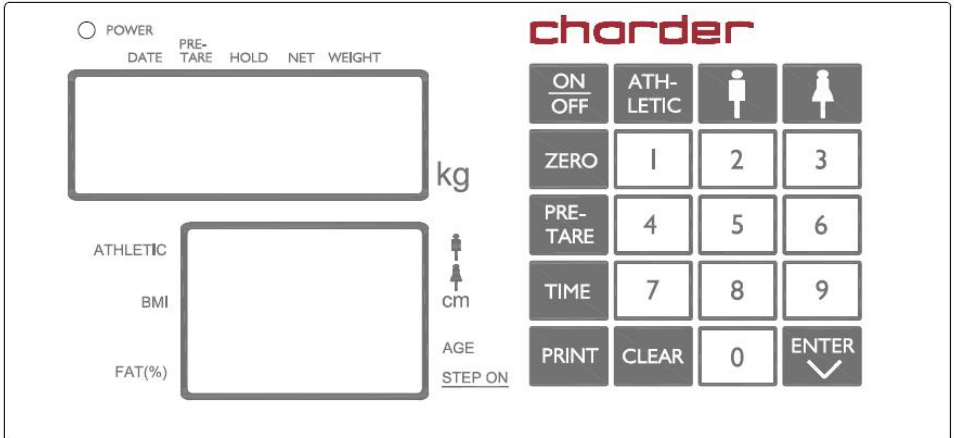

- A: Remote display (DP3710)
- B: Digital LCD
- C: Keypad
- D: Foot Electrodes
- E: Measurement Platform
- F: Adjustable feet
- G: Battery Type



B. Indicator and Key Functions



Key Function

1.  **ON/OFF**: Power on or power off.
2.  **ZERO**: Reset display to 0.0 kg display. Press and hold for 3 seconds to enter device settings.
3.  **PRE-TARE**: Pre-tare the known weight of an object (ex: clothing) before beginning measurement.
4.  **TIME**: Set time and date.
5.  **CLEAR**: Clear incorrect data input.
6.  **PRINT**: When printer or PC is connected to the scale, press this key to print results
7.  **ENTER**: Confirm input
8.  -  **0-9**: For entering digits.
9. **BODY TYPE**:

➤  : Male  : Female  : Athletic

NOTE: selecting appropriate body type

The "Athletic" setting is recommended for subjects that regularly perform

intense physical activity for at least 10 hours per week (or have previously maintained such a habit for an extended period of time), with a resting heart rate of approximately 60 beats per minute or less.

C. Display layout

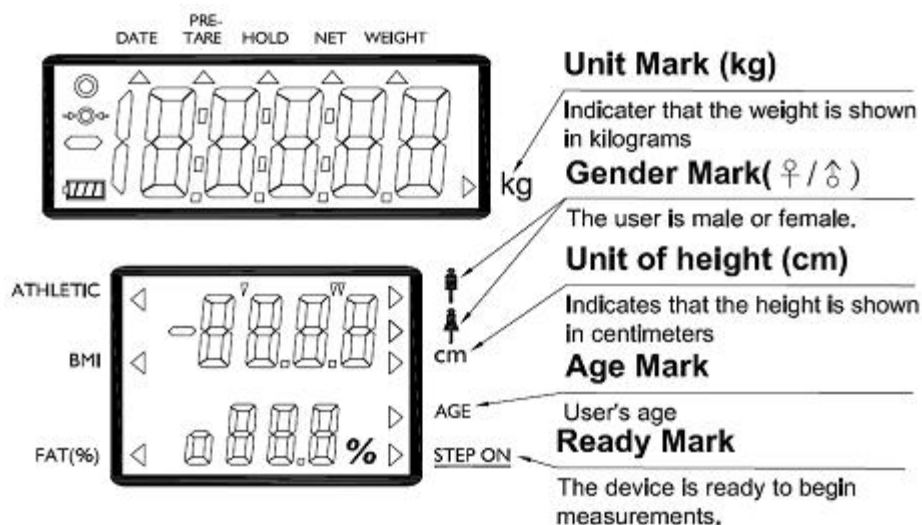
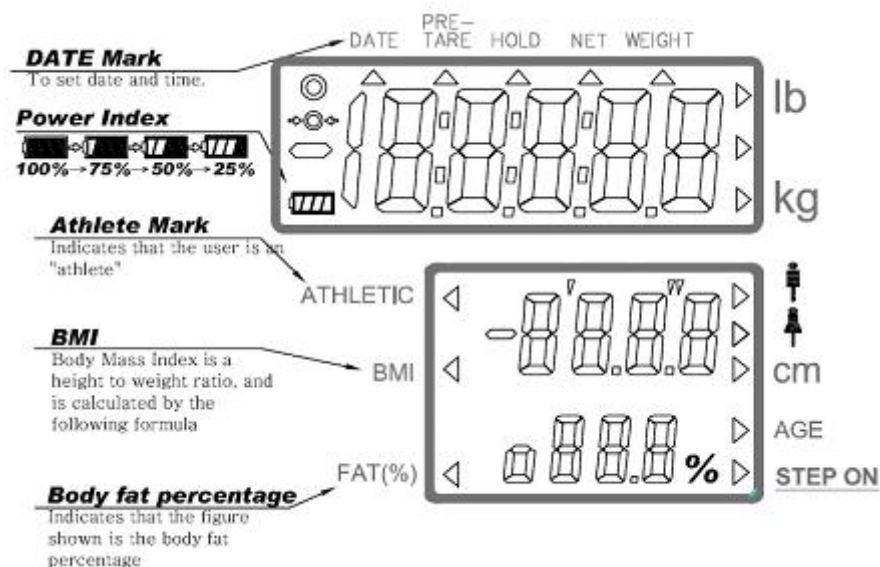

VI. Using Device

A. Setup Device for Measurement

To conduct a Body Composition Analysis using the MBF6000/MBF6010, the subject's height, age, and gender needs to be input prior to measurement.

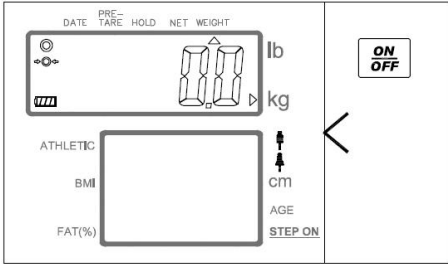

1. Press the **ON OFF** key. "0.0" will appear on the upper portion of the display.

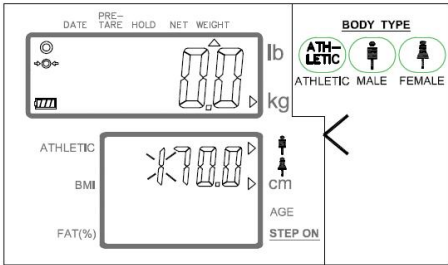

2. Select the body type from standard male, standard female, and athletic. Press **ENTER** to enter setting mode.

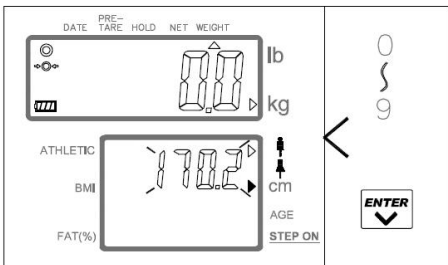



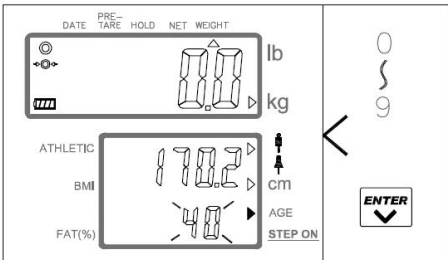



3. Use keypad to enter the subject's height and age when prompted.



B. Pre-Tare

The Pre-Tare function is used to subtract the known weight of a substance prior to weighing.

DESCRIPTION	EXAMPLE
<p>Press  key. Left-most digit will begin blinking.</p> <p>If no further action is taken within 6 seconds, indicator will return to normal mode</p>	
<p>While digit is blinking:</p> <p>Enter pre-tare weight using 0~9 keys.</p> <p>Ex: to pre-tare 5.0 kg of weight, press 0-0-5-0.</p> <p>Ex: to pre-tare 13.5 kg of weight, press 0-1-3-5.</p> <p>Press  key to confirm the pre-tare weight.</p>	
<p>Indicator will display minus sign to the left of pre-tare weight value.</p>	

NOTE: Pre-tare weight must be under max capacity, otherwise screen will show 0.00 after  key is pressed, and the operator will have to re-input pre-tare settings.

C. Conduct Measurement

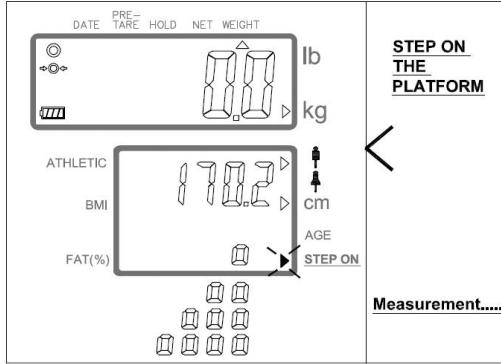

1. When subject's data (gender, height, age) has been input, indicator will display a flashing arrow next to STEP ON when ready.

2. Instruct subject to step on the four electrodes of platform **with bare feet**. Subject should stand in a stable position without bending your knees.

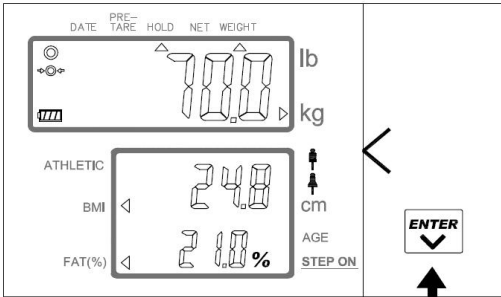

3. After subject has stepped onto weighing platform, weight will be displayed on the LCD. will appear at the bottom of the display, and the impedance measurement will begin.

The marks will disappear one by one during the measurement; after three full cycles, the measurement will be complete.

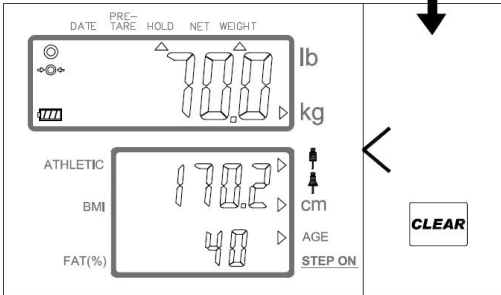

4. The measurement results can be displayed using the key. To conduct additional measurements, press to delete the data, and return to Step 1.

D. Print

If thermal printer is connected to indicator, results can be printed by pressing  key.

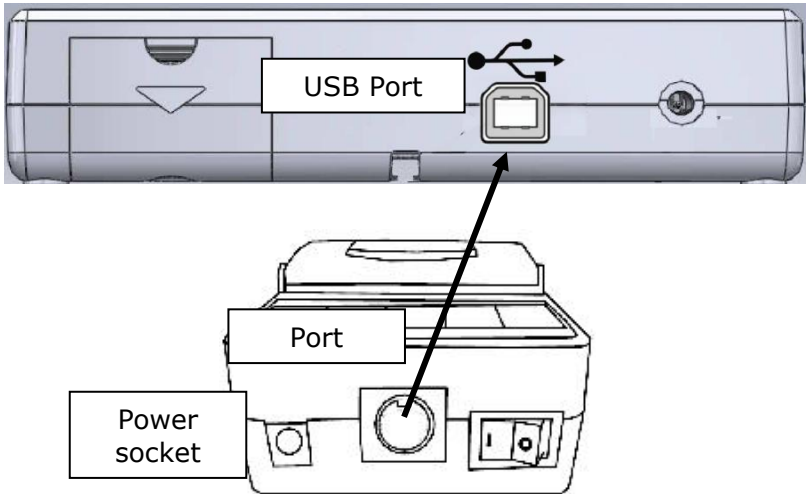

NOTE: Thermal printer needs to be powered by adapter

E. Measurement Results Explained

BMI (Body Mass Index)

BMI is a commonly used index by the World Health Organization (WHO), utilizing height and weight to classify underweight, normal, over, and obesity in adults.

Category	BMI (kg/m ²)	Risk of obesity-related disease
Under	< 18.5	Low
Normal	18.5-24.9	Average
Over	24.9-29.9	Slightly Increased
Obese I	30.0-34.9	Increased
Obese II	35.0-39.9	High
Obese III	> 40	Very High

(World Health Organization adult BMI standards)

FAT% (Body Fat Percentage)

Body fat percentage is useful in determining the specific cause of weight loss or gain. Average percentages differ according to specified groups and categories, most significantly by gender. Although no universally accepted published ranges or cut-off points for body fat percentage

currently exist, it is still an important value in assessing change in body composition and health.

FM (Body Fat Mass)

An essential level of fat is required for the body to function, though excessive fat can result in obesity-related diseases.

FFM (Fat-Free Mass)

Fat-Free Mass is the weight of the body after deducting total fat mass. In other words, FFM is the weight of everything except body fat.

BMR (Basal Metabolic Rate)

Basal Metabolic Rate is the minimum required energy to sustain the body's vital functions while at rest. These functions include breathing, blood circulation, regulation of body temperature, cell

Charder	
MBF-6000	
31/03/2009	14:55
BODY TYPE	STANDARD
GENDER	MALE
AGE	40
HEIGHT	170.2 cm
PRE-TARE	0.0 kg
NET WEIGHT	70.0 kg
BMI	24.7
FAT%	21.0 %
FM	14.7 kg
FFM	55.3 kg
BMR	1660 kcal
TBW	40.6 kg
IMPEDANCE	402.2ohm

(Simplified sample print-out for reference only)

growth, brain function, and nerve function. BMR tends to decrease with age or reduction in weight, and is positively correlated with increase in muscle.

TBW (Total Body Water)

Total Body Water (TBW) refers to the water contained in the tissues, blood, bones, and elsewhere. TBW in a healthy (non-obese) adult can fluctuate by roughly 5% daily, influenced by physiological activity and consumption of food and drink¹. Due to larger size and muscle mass, healthy adult men have more TBW than women (on average)².

For healthy (non-obese) adults, TBW constitutes ~60% of body weight and ~73% of Fat-Free Mass³. However, it is important to note that this percentage is not applicable to children - typically, children have a higher percentage of body water than adults, and TBW levels reportedly decrease further around middle age as part of the aging process⁴. In addition, various diseases can affect body water percentage, including renal deficiency diabetes, cardiac failure, and cancer⁵. Therefore, BIA estimations should be used with particular caution if subject's body water differs significantly from the representative populations used to formulate BIA algorithms.

TBW can be divided into Intracellular Water (ICW) and Extracellular Water (ECW). ICW:ECW proportion for healthy populations is roughly 3:2 (ECW/TBW= ~ 0.38)⁶.

BM (Bone Mineral content)

Higher bone mineral content may be an indicator of higher bone density.

MM (Muscle Mass)

¹ Askew EW Present Knowledge in Nutrition (7th ed) 1996, p.98-107

² Lesser GT, Markofsky J. Body water compartments with human aging using fat-free mass as the reference standard. 1979. Am J Physiol, 236, p.R215-R220.

³ Wang ZM, Deurenberg P, Wang W, Pietrobelli A, Baumgartner RN, Heymsfield SB. Hydration of fat-free body mass: review and critique of a classic body-composition constant. The American Journal of Clinical Nutrition. 1999. Vol.69 Issue 5, p.833-841.

⁴ Cameron CW, Guo SS, Zeller CM, Reo NV, Siervogel RM. Total body water for white adults 18 to 64 years of age: The Fels Longitudinal Study. 1999. Kidney International Vol.56 Issue 1, p.244-252

⁵ Moore FD, Haley HB, Bering EA, Brooks L, Edelman I. Further observations on total body water. Changes of body composition in disease. 1952. Surg GynecolObstet, 95, p.155-180

⁶ Tai R, Ohashi Y, Mizuiuri S, Aikawa A, Saki K. Association between ratio of measured extracellular volume to expected body fluid volume and renal outcomes in patients with chronic kidney disease: a retrospective single-center cohort study. BMC Nephrology, 2014;15:189

Increase in muscle mass increases BMR, which in turn allows the body to burn calories more quickly.

PM (Protein Mass)

The total amount of protein in the body.

SM (Skeletal Muscle)

Cardiac muscle, smooth muscle, and skeletal muscle are the three major muscle types found in the body. Skeletal muscle mass correlates with athletic performance, as it is under voluntary control and used to power movement. In addition, it can be developed actively through proper nutrition and training, thus making this value an important indicator for evaluation of fitness progression.

HS (Health Score)

The overall health score is calculated using the body composition readings. It works on a percentage basis, with 100 being the highest possible score attainable.

VFA (Visceral Fat Level)

Abdominal fat can be divided into visceral and subcutaneous fat. Visceral obesity can occur even if a subject's weight or BMI is within normal standards. Such subjects are thin on the outside, but fat on the inside⁷. Visceral fat level has high correlation with risk of a variety of obesity-related diseases, including cardiovascular diseases and Type-2 diabetes⁸⁹.

AGEM (Metabolic Age)

The subject's Basal Metabolic Rate is compared to average BMR for his/her age and gender group.

⁷Dudeja V, Misra A, Pandey RM, Devina G, Kumar G, Vikram NK. BMI does not accurately predict overweight in Asian Indians in northern India. *Br J Nutr.* 2001;86:105-112

⁸ Sandeep S, Gokulakrishnan K, Velmurugan K, Deepa M, Mohan V. Visceral & subcutaneous abdominal fat in relation to insulin resistance & metabolic syndrome in non-diabetic south Indians. *Indian J Med Res.* 2010;131:629-635.

⁹ Klein S. The case of visceral fat: argument for the defense. *J Clin Invest.* 2004;113(11):1530-1531

IMPEDANCE

In the conventional 4-electrode foot-to-foot BIA method, current is supplied from the electrodes at the tips of the toes on both feet, with the voltage measured on the heel. This current flows from one lower limb through the lower abdomen and then into the other lower limb, and the bioelectrical impedance is measured. For reference, the impedance measurement methods for the legs are shown in the diagram.

The MBF-6000/6010 measures impedance at 50kHz to calculate body composition results.

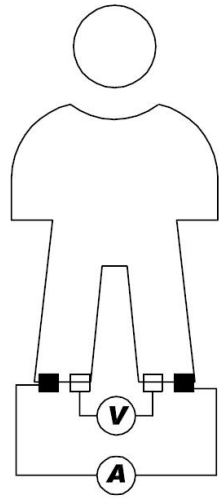

F. About Bioelectrical Impedance Measurement

The MBF6000/MBF6010 uses Bioelectrical Impedance Analysis (BIA) to calculate body composition. At its core, BIA operates by treating the human body as an electrical conductor within an alternating current circuit, from which the alternating current resistance and impedance is measured.

Using a combination of existing population data and in-house research, body composition analysis formulas can calculate results based on the Impedance, Height, Gender, Age, and Weight of the subject. These algorithms are formulated with reference to "gold standard" measurements such as Dual-Energy X-ray Absorptiometry (DXA) to confirm viability and accuracy.

Measurement Rules

For best results, body composition analysis via BIA should be conducted under specific conditions. Inconsistent measuring conditions will affect the accuracy and validity of BIA results, and interpretation of body composition. The information below regarding the effect of various factors on measurement results is largely sourced from related research by Kushner et al¹⁰. Before measurement, please take note of the following:

1. Do not exercise or perform strenuous physical tasks before measurement

Strenuous physical tasks and exercise can result in a temporary change

¹⁰ Kushner RF, Clinical characteristics influencing bioelectrical impedance analysis measurements, 1996

in body composition measurements. As BIA analyzes electrical impedance in the body, activities that might affect impedance (e.g. increased perspiration, dehydration, blood circulation) may affect measurement accuracy.

2. Affect of food and drink on measurement results

Ingestion of food and drink can affect impedance and weight, and thus analysis results. This change generally lasts 2-5 hours after each meal. For most accurate results, BIA measurements should ideally be conducted in a fasting state (e.g. before breakfast)¹¹.

3. Do not shower or bathe directly before measurement.

Perspiration can result in a temporary change in body composition measurements, as the accuracy of BIA depends largely upon interpretation of measured impedance values, which are affected greatly by hydration levels.

4. Perform the measurement under normal temperature conditions (24-28°C)

Extreme temperatures (both hot and cold) can result in temporary physiological changes. For example, excessive sweating due to heat can cause increased impedance measurements, resulting in a higher fat calculation. For best results, measurements should be conducted in an environment between 24-28°C.

5. Remove shoes and socks before measurement.

Shoes and socks will interfere with the electric current, making measurement inaccurate or in some cases, impossible.

6. Avoid physical contact with other people during measurement.

Because BIA measures the impedance encountered as the electric current travels through the subject's body, if another individual is touching the subject, the electric current may pass through the other individual, causing inaccuracy in measurement results.

7. Measure height accurately

Inaccurate height input will affect estimation of body composition.

8. Perform the measurement in the morning.

As a general rule, BIA measurements should be performed in the morning

¹¹ R Gallagher, M & Walker, Karen & O'Dea, K. The influence of a breakfast meal on the assessment of body composition using bioelectrical impedance. European journal of clinical nutrition. 52. 94-7.

to minimize the influence of activity throughout the day on measurements¹².

VII. Device Setup

A. Setting Time & Date

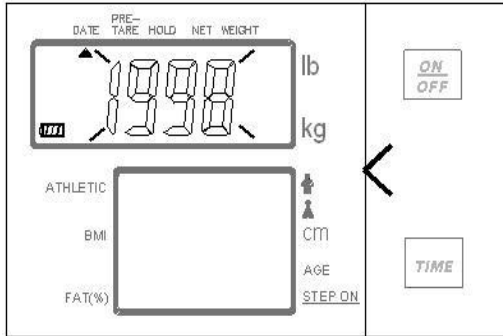

1. Press **ON/OFF** key to power on the device.

2. Press **TIME** key once.

3. The date input screen will appear. The upper row of numbers represents years (YYYY).

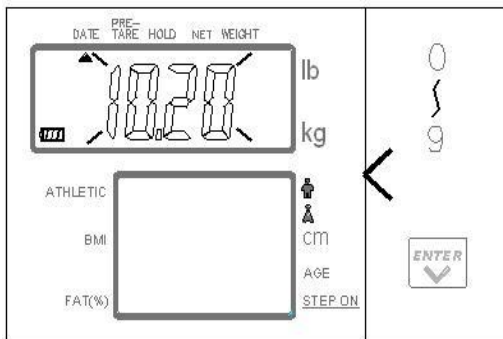

4. Input year in the flashing space.

Press **TIME** to enter the date.

Example: To input 2020, Oct 20, 6:28pm, press the following keys in order:

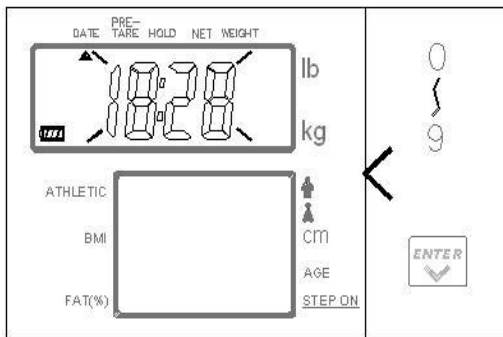
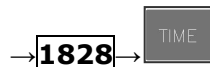
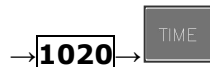
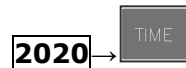

5. Press **TIME** key. The date and time are set, and the clock function is running. The display will now return to the step prior to entering this mode.

¹²Oshima Y & Shiga T. Within-day variability of whole-body and segmental bioelectrical impedance in a standing position, European Journal of Clinical Nutrition 2006, 60, 938-941

B. Device Setup

When the device is switched on, press and hold the  key for about 3 seconds, until the display shows the "SETUP", followed by "A.OFF" (first option in setting menu).

In device setup menu:

 to toggle next menu option

 to toggle previous menu option

 to confirm selection / enter submenu

After selecting menu option:

 key to toggle between options

 key to confirm selection



Auto Power-Off: Instruct device to shut off automatically after a certain period of time.

Auto off options: 120 sec / 180 sec / 240 sec / 300 sec / off

Press  to toggle, and  key to confirm selection.





Buzzer/Beep:

When function is turned on, beeping noise will be made when: indicator is turned on, keys are pressed, and weight is stable.

Press  to toggle on/off, and  key to confirm selection.

LANGU

Language: Set thermal printer language

Press  to toggle between English and Polish. Press  key to confirm selection.



BT irEL

BT / Wifi (optional): If device has BT or Wifi module installed, the function can be turned OFF/BT/Wifi.

Press **[HOLD]** to toggle between OFF/BT/Wifi, and **[TARE]** to confirm selection.

WIFSET

Wi-Fi Setting (optional): If device has Wi-Fi module installed, this option will appear.

Press  to toggle between "Auto" and "PKEY". Press  to confirm selection.

If "Auto" is selected, weight measurement will be automatically sent to connected printer or device. If "PKEY" is selected, transfer will occur manually only after  key is pressed.

Save Changes

After completing changes, press  until "END" is displayed on screen.

Press  to save.

VIII. Connecting scale to receiving device

The device can transfer results to receiving device. Please consult instruction manual for receiving device.

Connection directly to Electronic Medical System should be conducted by qualified distributors/administrators only.

NOTE: Wireless transfer is only available on wireless model.

IX. Troubleshooting

Before contacting your local Charder distributor for repair service, we recommend considering the following troubleshooting procedures:

Self-inspection

1. Device will not power on

- If battery power is depleted, replace with new batteries
- If batteries are not used, check if the power adapter is plugged into the device properly. Check if power adapter is plugged into mains properly

2. Indicator showing "0000" ZERO SPAN out of range

- Interference due to factors such as RF disturbance or ground vibration. Relocate device to location without interference and try again
- Unstable platform feet - adjust platform feet according to bubble level indication (clockwise to retract, counter-clockwise to extend) and try again
- External objects interfering with measurement platform. Clear platform of objects and try again
- Device may not function properly on soft surfaces such as carpets or lawns. Relocate device to location with solid, stable floor
- If the steps above cannot resolve the problem, re-calibration may be required to correct weighing accuracy

3. Connection failure for data transmission to PC or printer

- Ensure wires are connected correctly between indicator and PC or printer

- Ensure printer is supplied with power. Ensure PC software is set up properly as indicated in this manual

Distributor support required

If the following errors occur, we recommend contacting your local Charder distributor for repair or replacement services:





1. Device will not power on







- Faulty on/off key
- Broken or damaged wires causing short circuit or faulty connection
- Safety fuse burnout
- Faulty adapter

2. Indicator damage

- Possible hardware defects include: uneven brightness in LCD screen, blurred text, smeared rainbow screen, incorrect decimal display
- Unable to save or read data
- Indicator shows "ERR.L" after device is switched on
- Keys not responding
- Buzzer malfunction

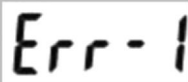
Error Messages

Error Message	Reason	Action
	Low battery warning Voltage of battery is too low to operate device	Replace batteries, or plug in adapter
	Overload Total load exceeds device's maximum capacity	Reduce weight on measurement platform and try again
	Counting Error (too high) Signal from loadcells too high	Error normally caused by faulty loadcell or wiring. Please contact distributor
	Counting Error (too low) Signal from loadcells too low	Error normally caused by faulty loadcell or wiring. Please contact distributor
	Zero count over calibration zero range +10% while power on	Re-calibration required. Please contact distributor

	Zero count under calibration zero range -10% while power on	Re-calibration required. Please contact distributor
	Program Error Fault with device software	Please contact distributor
	Program Error Fault with device software	Please contact distributor
	Impedance Error Impedance exceeds measurement limits	Try measurement again. Contact distributor if problem persists
	Impedance Error Impedance cannot be measured	Try measurement again. Contact distributor if problem persists
	Result Error Calculated results are invalid	Try measurement again. Contact distributor if problem persists
	Impedance Error Impedance exceeds measurement limits	Try measurement again. Contact distributor if problem persists

X. Product Specifications

A. Device Information

Model		MBF6000 / MBF6010
Weight Measurement	Capacity	300kg x 0.1kg
	Accuracy	Weight Measurement Accuracy ±1.5e
	Weight Unit	kg (OIML), kg / lb (CE model)
	LCD Screen	0.8-inch LCD screen (Three row LCD)
	Key Functions	On/Off, Zero, Pre-Tare, Body Type, 0~9, Clear, Enter, Time, Print
Impedance Measurement	System	4-electrode Bioelectrical Impedance Analysis
	Accuracy	Impedance Measurement accuracy± 3%
	Current	50kHz 500uA
	Style	Left leg-Right leg Foot-to-foot
	MeasurementRange	200 ~ 1000Ω / 0.1Ω
Input Items	Gender	Male / Female
	Body Type	Standard / Athletic
	Age	10 ~80 years old
	Height	60 ~ 210cm / 3ft ~ 7ft11.0in
Dimensions	Overall	450(W) x 450(D) x 970(H) mm
	Platform	450(W) X 340(D) X 90(H) mm
	Column	(MBF6010 only) 850 mm
Device Weight		(MBF6000) 8.6 kg (MBF6010) 10.2 kg
Data Transmission		USB, Wireless Module (optional) NOTE: Device should be connected to network by qualified distributors only
Power Supply		7.2V 2000mA rechargeable battery or 6 AA batteries / adapter

Operation Environment	0°C~+40°C 30% / 80% RH, 700 hPa ~1060 hPa
Standard Accessories	User manual*1, Power Adapter*1, USB cable*1
Optional Accessories	Thermal Printer, HeightStadiometer

B. Output Items (Display and Print-out)

MODEL	MBF6000 / MBF6010	
Serial Number	C12345678 (example)	
Date/Time	DD/MM/YYYY hh:mm EX: 30/10/2020 10:55	
Body Type	Standard / Athletic	
Gender	Male / Female	
Age	10 ~ 80 years old / 1 year increments	
Height	60 ~ 210cm / 3ft ~ 7ft11.0in	
Preset Tare	0 ~ 299 kg	
Net Weight	0 ~ 300 kg	
BMI	Body Mass Index	0.1 increments
BF %	Body Fat Percentage	5 ~ 50% / 0.1% increments
FFM	Fat-Free Mass	0.1kg increments
FM	Fat Mass	0.1kg increments
BM	Bone Mineral	0.1kg increments
MM	Muscle Mass	0.1kg increments
BMR	Basal Metabolic Rate	1 kcal increments
TBW	Total Body Water	0.1L increments
PM	Protein Mass	0.1kg increments
ICW	Intracellular Water	0.1L increments
ECW	Extracellular Water	0.1L increments
SM	Skeletal Muscle	0.1kg increments
HEALTH SCORE		XX.X score
VFALEVEL	Visceral Fat Level	Visceral Fat Level
AGEM	Metabolic Age	XX.X
IMPEDANCE		XXX.X ohm

C. Power Adapter Standards



Warning

The device is only compatible with the power adapters specified in the dashed block below.

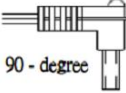
Amp Voltage	Drawing No.	CE Approved Type No./Model No.	Type	
12V 2A	CD-AD-00041	UES24LCP-120200SPA	US	 90 - degree
	CD-AD-00041	UES24LCP-120200SPA	EU	
	CD-AD-00041	UES24LCP-120200SPA	UK	
	CD-AD-00041	UES24LCP-120200SPA	AU	

XI. Declaration of Conformity

Manufacturer hereby declares that this product is in conformity with the regulations and standards outlined in the following directives:

	(EU) 2017/745 Regulation on Medical Devices
	2014/31/EU Non-automatic Weighing Instruments Directive

RoHS Directive 2011/65/EU and Delegated Directive (EU) 2015/863

Radio equipment and telecommunications terminal equipment Directive 2014/53/EU

(applicable if device has wireless function)

Part 15 of the Federal Communications Statement Rules

This device may not cause harmful interference

This device must accept interference received without causing undesired operation

(Full Declaration of Conformity is available on manufacturer's website)

Authorized EU Representative:



Obelis s.a.

Bd Général Wahis, 53
B-1030 Brussels
Belgium

Manufactured by:



Charder Electronic Co., Ltd.
No.103, Guozhong Rd., Dali Dist.,
Taichung City, 41262 Taiwan

CD-IN-1256 14202S 01/2026