













USER MANUAL
MA601
Body Composition Analyzer



Explanation of Graphic Symbols on Label/Packaging

| Text/Symbol | Meaning |
|--|---|
|  | Caution. Failure to follow instructions may result in adverse events |
|  | Separate collection for waste of electrical and electronic equipment, in accordance with Directive 2002/96/EC. Do not dispose of device with everyday waste |
|  | Name and address of device manufacturer |
|  | Carefully read user manual before installation and usage, and follow instructions for use. |
|  | Medical electrical device, Type BF applied part |
| REF | Device catalogue number |
|  | Name and address of authorized representative in the European Union |
| MD | Device is a medical device. Text indicates device category type |
| LOT | Manufacturer's batch or lot number for device |
| SN | Device's serial number |
|  | Device's model number |
| UDI | Device's Unique Device Identifier (01) GTIN (11) Production date (21) Serial number |
| e | Verification Scale Interval. Value expressed in units of mass. Used for classification and verification of an instrument. |
|  2460 | Device conforms to (EU) 2017/745 Regulation on Medical Devices. Four digit number is identifier for medical device Notified Body |
| CEM170122 | Device complies with EC directives (verified models only) M: Conformity label in compliance with Directive 2014/31/EU for Non-Automatic Weighing Instruments 17: Year in which conformity verification was performed and CE label was applied. (ex: 17=2017) 0122: Identifier for metrology Notified Body |

| | |
|---|--|
|  | Device is a Class III scale in compliance with Directive 2014/31/EU |
|  | Name and address of entity importing device |
|  | Name and address of entity responsible for translating Information For Use |
| CON. | Event counter recording how many times protected-mode parameter adjustments (ex: gravity value) have been conducted for device |
|  | Device has received Taiwan NCC approval |
| FC | Device conforms to U.S. Federal Communications Commission regulations |
| UK CA | Device complies with all UK applicable product legislation |
|  | Device's polarity of power. |

In case of differences, icon on device itself takes precedence

NOTE

After the device has been turned on, the screen will remain dark for about 10 seconds. This is normal, and the device will continue with self-calibration process.

Copyright Notice

Charder Electronic Co., Ltd.

No.103, Guozhong Rd., Dali Dist.,
Taichung City 41262 Taiwan

Tel: +886-4-2406 3766

Fax: +886-4-2406 5612

Website: www.chardermedical.com

E-mail: info_cec@charder.com.tw

Copyright©Charder Electronic Co., Ltd. All rights reserved.

This user manual is protected by international copyright law. All content is licensed, and usage is subject to written authorization from Charder Electronic Co., Ltd. (hereinafter Charder) Charder is not liable for any damage caused by a failure to adhere to requirements stated in this manual. Charder reserves the right to correct misprints in the manual without prior notice, and modify the exterior of the device for quality purposes without customer consent.



Charder Electronic Co., Ltd. No. 103, Guozhong Rd., Dali Dist.,
Taichung City, 41262 Taiwan

CONTENTS

| | |
|--|-----------|
| 1. SAFETY NOTES | 6 |
| A. General Information | 6 |
| B. Precaution Symbols | 9 |
| C. EMC guidance and manufacturer's declaration | 12 |
| 2. UNPACKING DEVICE | 15 |
| A. Unpacking | 15 |
| B. Contents | 16 |
| C. Device Parts | 17 |
| 3. INSTALLATION | 19 |
| A. Environment | 19 |
| B. Setup | 20 |
| C. Optional Accessories | 20 |
| D. Startup | 22 |
| 4. BEFORE MEASUREMENT | 23 |
| 5. MEASURING INSTRUCTIONS | 25 |
| A. Creating / Selecting User | 25 |
| B. Measurement | 26 |
| C. Measurement Posture | 28 |
| 6. SETTINGS | 31 |
| 7. FREQUENTLY ASKED QUESTIONS | 38 |
| 8. SPECIFICATIONS | 39 |



1. SAFETY NOTES

A. General Information

Thank you for choosing this Charder Medical device. It is designed to be easy and straightforward to operate, but if you encounter any problems not addressed in this manual, please contact your local Charder service partner. Before beginning operation of the device, please read this user manual carefully, and keep it in a safe place for reference. It contains important instructions regarding installation, proper usage, and maintenance.

Intended Purpose

This medical device is designed to estimate body composition in professional settings in accordance with national regulations. The device measures the patient's weight and bioelectrical impedance measurements using foot and hand touch electrodes, combining them with input data (ex: age, gender, height) to estimate:

Skeletal Muscle Mass, Extracellular Water (ECW), Intracellular Water (ICW), Total Body Water (TBW), ECW/TBW, Body Fat, Percent Body Fat (PBF), Metabolic Rates (Basal Metabolic Rate, Total Energy Expenditure), Segmental Lean Mass, Segmental Fat Mass, Visceral Fat Level, Body Type Analysis, Weight Control, Fat Control, Muscle Control, Body Balance, Health Score, Fat-Free Mass (FFM), Fat-Free Mass Index (FFMI), Skeletal Muscle Index (SMI), Appendicular Skeletal Muscle Index (ASMI), Grip Strength, Protein, Minerals, Soft Lean Mass, Waist-Height Ratio, Growth Chart, Growth History, Evaluation & Recommendations, Core Muscle, Fitness Score

The device is not a diagnostic device. Results should be used as part of a broader comprehensive assessment.

Caution

Usage of Results

- The MA601 is not a diagnostic device. Results should be interpreted with assistance from a professional.
- BIA results are calculated based on impedance values validated with representative population studies and statistical analysis. As such, the technique is best suited for tracking progress for an individual over a period of time, or for categorizing large groups of people, rather than used as a one-time analysis. Accuracy of results is highly dependent on proper measurement procedure.

1. SAFETY NOTES

Clinical Benefit

The device is used for body measurement/estimation. The measurement results can be used in such a wide variety of applications that it may not be practical or beneficial to narrowly define the associated clinical benefits of receiving such results. Therefore, the benefit of the device is that it is able to perform its intended (measurement/estimation) function. A list of potential applications for key measurement outputs includes but is not limited to:

| Result Category | Example Result | Example Application |
|-------------------|---|--|
| Fat | Whole-body Fat, Segmental Body Fat, Abdominal Fat | Obesity: evaluating risk of obesity-related diseases |
| Water | Total Body Water (TBW), Extracellular Water (ECW), Intracellular Water (ICW), Edema Index (ECW/TBW Ratio) | Peritoneal Dialysis: assessment of change in water balance before and after treatment |
| Muscle | Whole-body Muscle, Segmental Muscle, Skeletal Muscle, Fat-Free Mass, Muscle Quality (Estimated Grip Strength) | Sarcopenia: evaluating muscle mass and effectiveness to identify malnutrition or training/rehabilitation needs |
| Cellular Analysis | Bioelectrical Impedance Vector Analysis (BIVA), Phase Angle | Health Evaluation: assessing comparative cellular status and observing body status beyond muscle/fat/water |
| Metabolism | Basal Metabolic Rate (BMR), Total Energy Expenditure (TEE) | Nutrition: determining suitable level of daily caloric consumption based on goals and projected expenditure |

Intended medical indications/contraindications

Measurement: patient's body composition and body weight.

Contraindications

Measurement should not be conducted on patients with electronic medical implants (ex: cardiac pacemakers)

Intended user profile

- (a) At least 20 years old
- (b) Minimum knowledge:
 - To be able to read at a high-school level and understand Arabic numerals (e.g. 1, 2, 3, 4...)
 - Basic hygiene knowledge
 - Trained in device's operation
 - Read the instruction manual
- (c) Language
 - Able to read the language of instruction manual and on-screen instructions
- (d) Qualifications
 - No special certifications or qualifications required

Intended patient profile

- (a) Age: 6-85
- (b) Weight: within 300 kg
- (c) Patient Conditions: require measurement of body weight and body composition. Able to stand independently without support.

1. SAFETY NOTES

Residual risk evaluation







- (a) All foreseeable risks have been evaluated and considered acceptable. Generally speaking, the most likely risk caused by incorrect usage of the device is less accurate measurement (or inability to use device to acquire measurement), which does not pose imminent physical risk to patient or user.
- (b) Benefit-risk ratio is considered acceptable. Body composition analyzers are an important option for measuring patients. Usage of device is unlikely to result in harm to user or patient.

Incident Reporting

Any serious incident that has occurred in relation to the device should be reported to the manufacturer, EU representative (if device is used in EU member state), and competent authority of user/subject's member state.

1. SAFETY NOTES

B. Precaution Symbols

| | |
|--|--|
|  Warning | Identifies the possibility of serious injury or death for the user if the device is mishandled, or safety instructions are not followed. |
|  Caution | Identifies the possibility of physical injury or device damage if the device is mishandled, or safety instructions are not followed. |
|  | The caution symbol indicates general precautions that should be taken when using the device. |
| NOTE | Additional information regarding the operating environment, conditions for installation, or special conditions in usage. |
|  | Indicates helpful hints and supplementary information. |
|  | Indicates actions that should not be performed. |
| Bold | Bold text identifies buttons on the display panel or screen. |
|  | Hazard icon warning against possible electric shock. |

1. SAFETY NOTES

Caution: General Handling

- This device is intended for indoor use only.
- Do not place the device on slippery surfaces.
- Ensure all parts are properly locked and tightened before operating the device.
- Device is intended to measure one subject at a time.

Electric Shock

- Do not touch the power supply with wet hands.
- Do not crimp the power cable, and avoid sharp edges.
- Do not overload extension cables connected to the device.
- Route the network and power cable carefully, to avoid tripping.
- Keep the device away from liquids

Caution: Injuries and Infections

- Ensure that subjects do not have wounds or contagious diseases on the palms of their hands or the soles of their feet.
- For hygiene purposes, Charder recommends cleaning the measuring platform after each measurement with a soft cloth and alcohol.
- Ensure that the measuring platform is dry before usage.

Caution: Maintenance



- Please contact your local Charder distributor for regular maintenance and calibration. Regular checking of accuracy is recommended; frequency to be determined by level of use and state of device.

1. SAFETY NOTES

Caution

Preventing Device Damage

- Please contact your local Charder distributor for regular maintenance and calibration.
- This device does not contain any user-maintained parts. All maintenance, technical inspections, and repairs should be conducted by an authorized Charder service partner, using original Charder accessories and spare parts. Charder is not liable for any damages arising from improper maintenance or usage. Dismantlement of the device will void the warranty.

-  Take care to make sure fluids do not enter the device, as they may damage the internal electronics
- Switch off the device before disconnecting the power supply.
-  Do not place the device in direct sunlight, or in close proximity to an intense heat source. Excessively high temperatures may damage the internal electronics.
-  Strong cleaning agents can damage the measuring platform's surface.
Alcohol wipes can be used to clean the electrodes and weighing platform.
Alcohol-based cleaning solutions should not be used on the touch screen.
- The device has an expected service life of 5 years when correctly handled, serviced, and periodically inspected in accordance with manufacturer's instructions.

C. EMC guidance and manufacturer's declaration

| Guidance and manufacturer's declaration-electromagnetic emissions | | |
|---|-------------------|---|
| The product is intended for use in the electromagnetic environment specified below. The customer or the user of the product should assure that it is used in such an environment. | | |
| Emission test | Compliance | Electromagnetic environment-guidance |
| RF emissions CISPR 11 | Group 1 | The product uses RF energy only for its internal function. Therefore, its RF emissions are very low and are not likely to cause any interference in nearby electronic equipment. |
| RF emissions CISPR 11 | Class A | The product is suitable for use in all establishments other than domestic and those directly connected to a low voltage power supply network which supplies buildings used for domestic purposes. |
| Harmonic emissions IEC 61000-3-2 | Class A | |
| Voltage fluctuations /flicker emissions IEC 61000-3-3 | Compliance | |

| Guidance and manufacturer's declaration-electromagnetic immunity | | | |
|---|--|--|--|
| The product is intended for use in the electromagnetic environment specified below. The customer or the user of the product should assure that it is used in such an environment. | | | |
| Immunity test | IEC 60601 test level | Compliance level | Electromagnetic environment-guidance |
| Electrostatic discharge (ESD) IEC 61000-4-2 | <u>±8 kV contact</u> <u>±2 kV, ±4 kV,</u> <u>±8 kV, ±15 kV air</u> | <u>±8 kV contact</u> <u>±2 kV, ±4 kV,</u> <u>±8 kV, ±15 kV air</u> | Floors should be wood, concrete or ceramic tile. If floors are covered with synthetic material, the relative humidity should be at least 30% |
| Electrical fast transient/burst IEC 61000-4-4 | ±2kV for power supply lines | ±2kV for power supply lines | Mains power quality should be that of a typical commercial or hospital environment. |
| Surge IEC 61000-4-5 | ±1kV line(s) to line(s) ±2kV line(s) to earth | ±1kV line(s) to line(s) ±2kV line(s) to earth | Mains power quality should be that of a typical commercial or hospital environment. |

| | | | |
|---|--|--|--|
| Voltage Dips, short interruptions and voltage variations on power supply input lines IEC 61000-4-11 | <u>0% UT for 0,5 cycle</u> <u>0% UT for 1 cycle</u> <u>70% UT(30% dip in UT) for 25 cycles</u> <u>0% UT for 5 s</u> | <u>0% UT for 0,5 cycle</u> <u>0% UT for 1 cycle</u> <u>70% UT(30% dip in UT) for 25 cycles</u> <u>0% UT for 5 s</u> | Mains power quality should be that of a typical commercial or hospital environment. If the user of the product requires continued operation during power mains interruptions, it is recommended that the product be powered from an uninterruptible power supply or a battery. |
| Power frequency (50, 60 Hz) magnetic field IEC 61000-4-8 | <u>30 A/m</u> | <u>30 A/m</u> | The product power frequency magnetic fields should be at levels characteristic of a typical location in a typical commercial or hospital environment. |
| NOTE UT is the a.c. mains voltage prior to application of the test level. | | | |

| Guidance and manufacturer's declaration-electromagnetic immunity | | | |
|---|---|---|--|
| The product is intended for use in the electromagnetic environment specified below. The customer or the user of the product should assure that it is used in such an environment. | | | |
| Immunity test | IEC 60601 test level | Compliance level | Electromagnetic environment-guidance |
| Conducted RF IEC 61000-4-6 | 3 Vrms 150 KHz to 80 MHz <u>6 V in ISM bands between 0,15 MHz and 80 MHz</u> <u>80 % AM at 1 kHz</u> | 3 Vrms 150 KHz to 80 MHz <u>6 V in ISM bands between 0,15 MHz and 80 MHz</u> <u>80 % AM at 1 kHz</u> | Portable and mobile RF communications equipment should be used no closer to any part of the product including cables, than the recommended separation distance calculated from the equation applicable to the frequency of the transmitter. Recommended separation distance: $d = 1,2 \sqrt{P}$ $d = 1,2 \sqrt{P}$ 80MHz to 800 MHz $d = 2,3 \sqrt{P}$ 800MHz to 2,7GHz Where P is the maximum output power rating of the transmitter in watts (W) according to the transmitter manufacturer and d is the recommended separation distance in metres (m). Field strengths from fixed RF transmitters, as determined by an electromagnetic site survey, ^a should be less than the compliance level in each frequency range. ^b Interference may occur in the vicinity of equipment marked with the following symbol: |
| Radiated RF IEC 61000-4-3 | 3 V/m <u>80MHz to 2,7 GHz</u> | 3 V/m <u>80MHz to 2,7 GHz</u> |  |

NOTE 1 At 80 MHz and 800 MHz, the higher frequency range applies.

NOTE 2 These guidelines may not apply in all situations. Electromagnetic propagation is affected by absorption and reflection from structures, objects and people.

- a Field strengths from fixed transmitters, such as base stations for radio (cellular/cordless) telephones and land mobile radios, amateur radio, AM and FM radio broadcast and TV broadcast cannot be predicted theoretically with accuracy. To assess the electromagnetic environment due to fixed RF transmitters, an electromagnetic site survey should be considered. If the measured field strength in the location in which the product is used exceeds the applicable RF compliance level above, the product should be observed to verify normal operation. If abnormal performance is observed, additional measures may be necessary, such as re-orienting or relocating the product.
- b Over the frequency range 150 kHz to 80 MHz, field strengths should be less than 3V/m.

Recommended separation distance between portable and mobile RF communications equipment and the product

The product is intended for use in an electromagnetic environment in which radiated RF disturbances are controlled. The customer or the user of the product can help prevent electromagnetic interference by maintaining a minimum distance between portable and mobile RF communications equipment (transmitters) and the product as recommended below, according to the maximum output power of the communications equipment.

| Rated maximum output power of transmitter W | Separation distance according to frequency of transmitter m | | |
|--|---|--|--|
| | 150 kHz to 80 MHz $d = 1,2\sqrt{P}$ | 80 MHz to 800 MHz $d = 1,2\sqrt{P}$ | <u>800 MHz to 2,7 GHz</u> $d = 2,3\sqrt{P}$ |
| 0,01 | 0,12 | 0,12 | 0,23 |
| 0,1 | 0,38 | 0,38 | 0,73 |
| 1 | 1,2 | 1,2 | 2,3 |
| 10 | 3,8 | 3,8 | 7,3 |
| 100 | 12 | 12 | 23 |

For transmitters rated at a maximum output power not listed above, the recommended separation distance d in metres (m) can be estimated using the equation applicable to the frequency of the transmitter, where p is the maximum output power rating of the transmitter in watts (W) according to the transmitter manufacturer.

NOTE 1 At 80 MHz and 800 MHz, the separation distance for the higher frequency range applies.

NOTE 2 These guidelines may not apply in all situations. Electromagnetic propagation is affected by absorption and reflection from structures, objects and people.

2. UNPACKING DEVICE

A. Unpacking

1. Open box and remove accessories.

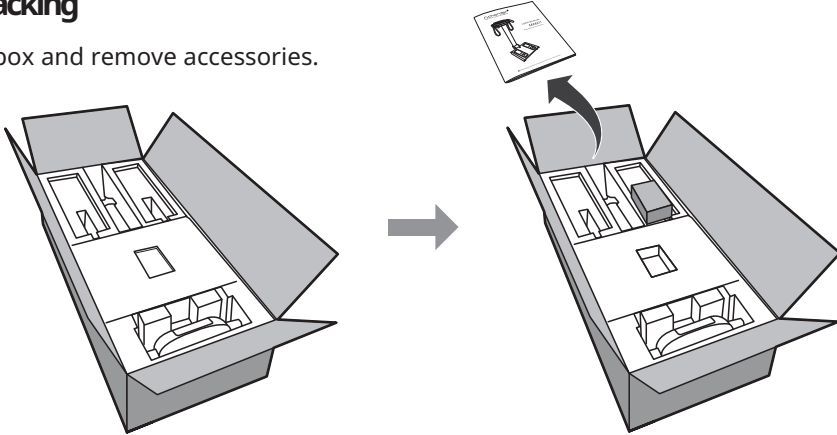

2. After removing packing foam, raise display column up into upright position.

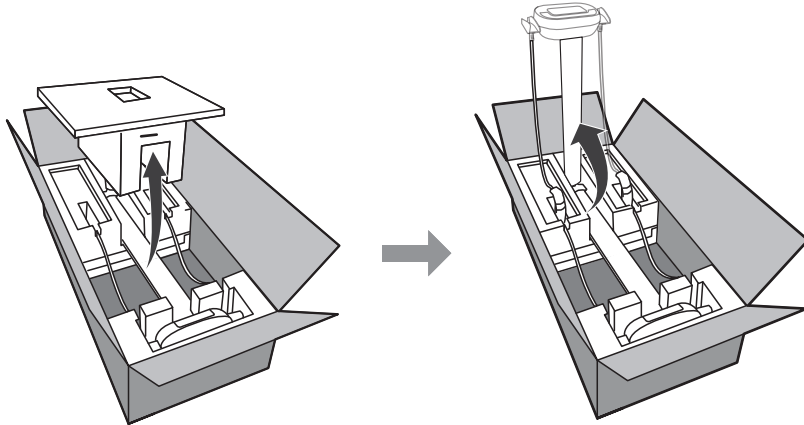

3. Place hand electrodes on electrode holders, and remove packing foam.

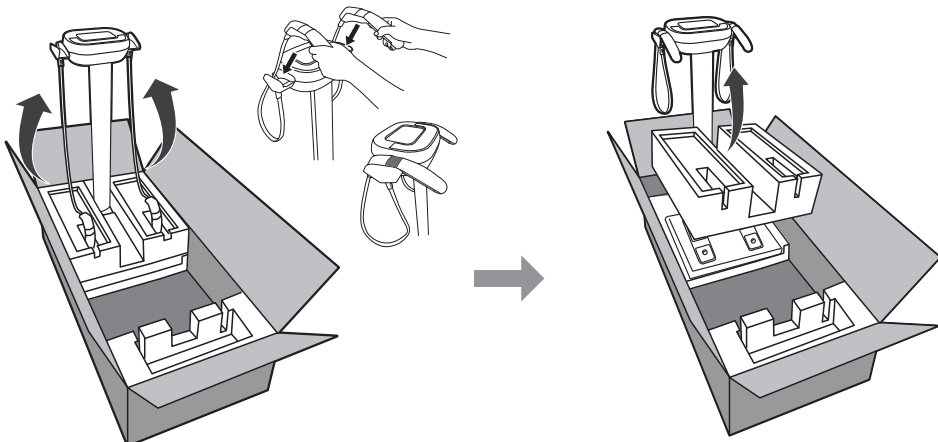

2. UNPACKING DEVICE

⚠ NOTE: At least two people are needed to remove the MA601 from its box

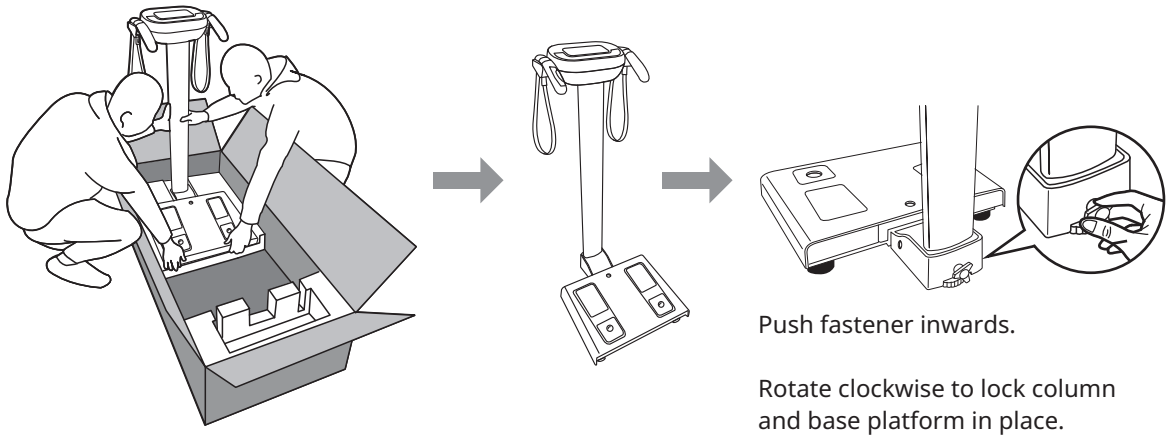

B. Contents

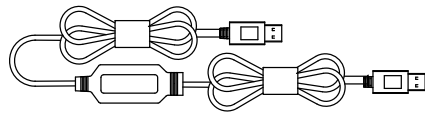
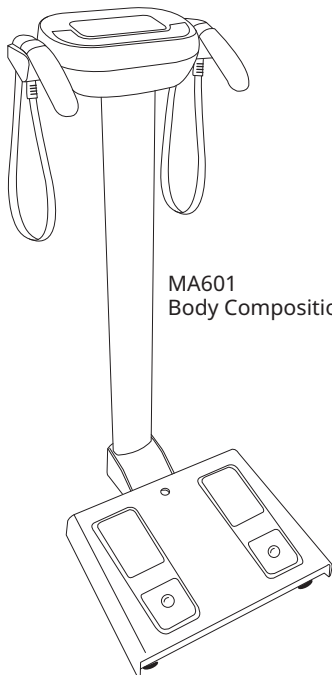

UA-010 USB Cable

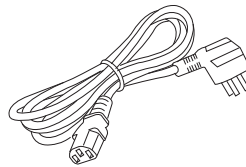

Power cord

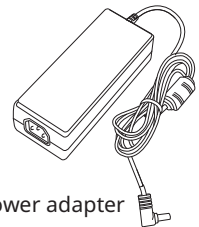

Power adapter

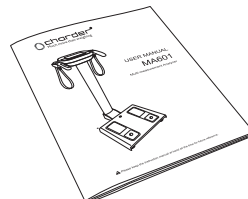

User manual

2. UNPACKING DEVICE

C. Device Parts

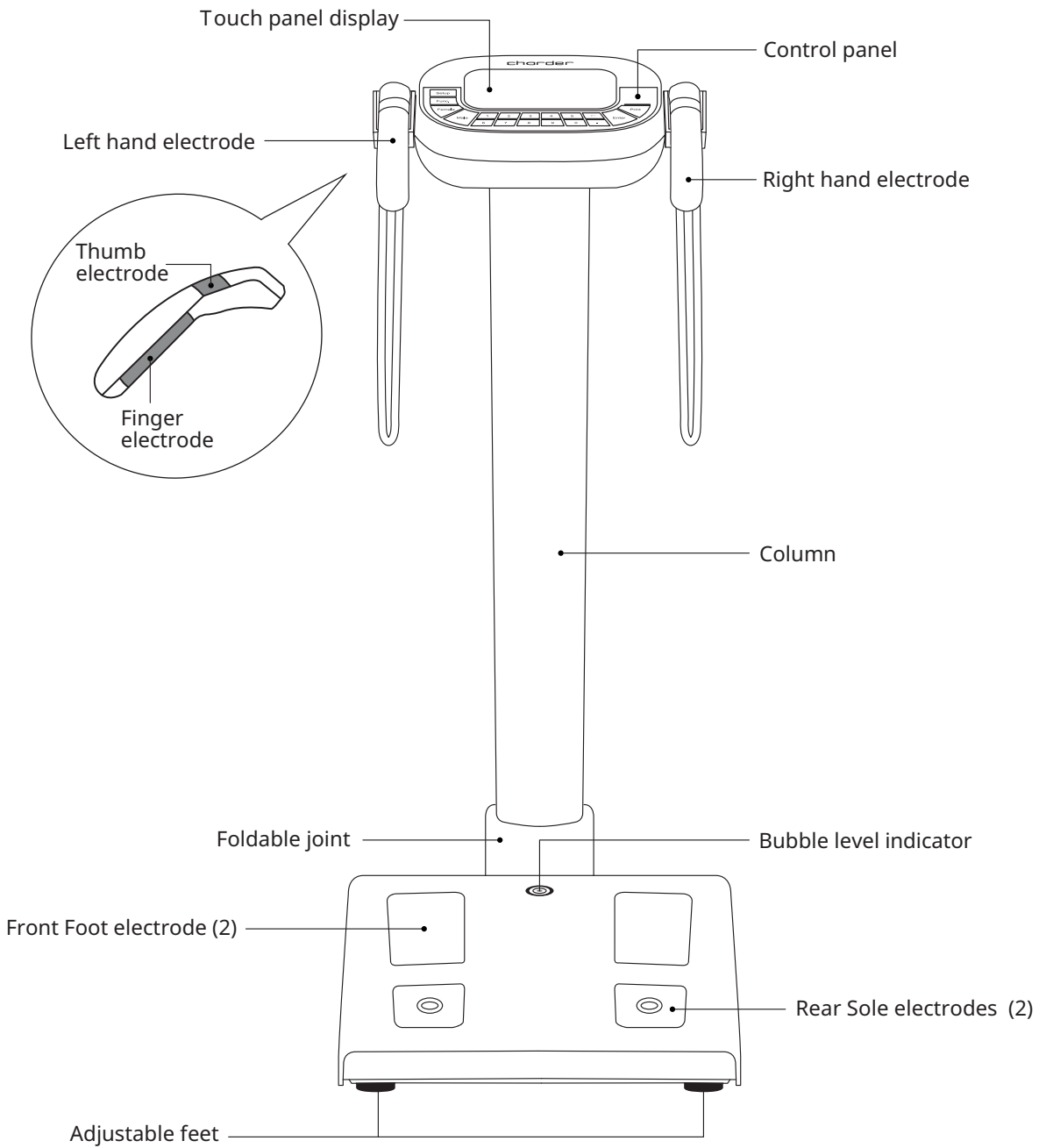

2. UNPACKING DEVICE

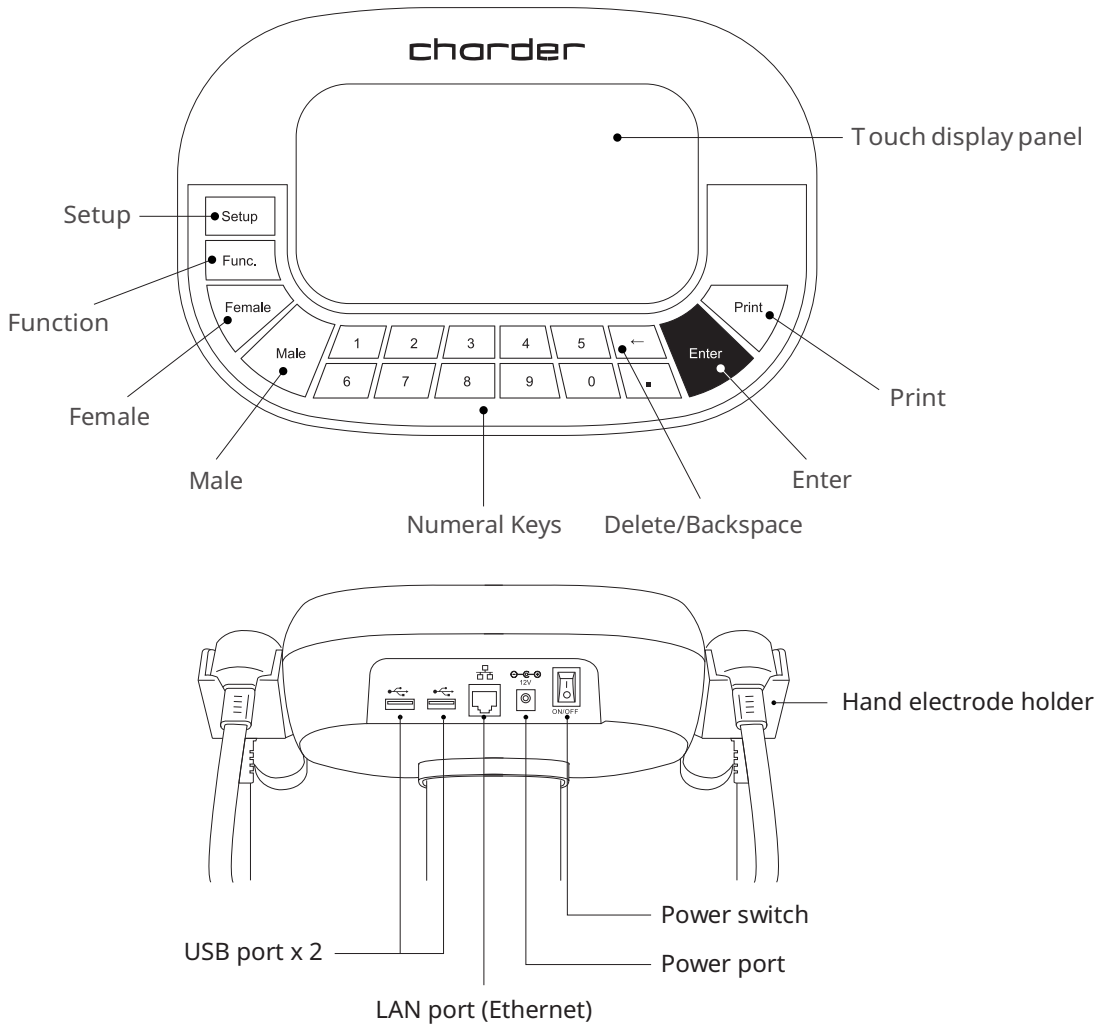

  **USB port:** Connect device to a printer, flash drive, or PC

  **LAN port:** Connect device to a network

 **Power port:** Connect device to mains power

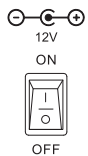
 **Power switch:** Turn device on/off

3. INSTALLATION

A. Environment

The device should be placed on a flat and hard surface. Usage on carpet may result in static electricity, which may damage the equipment and cause inaccuracies in measurement.

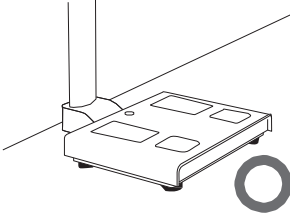
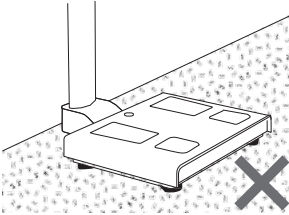
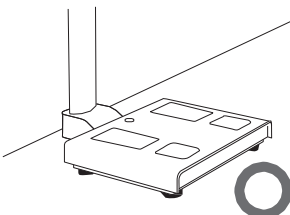
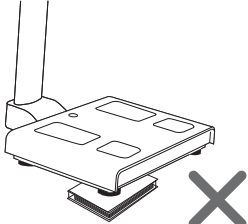
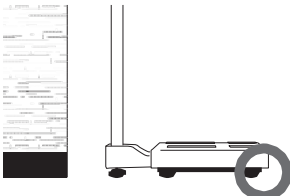
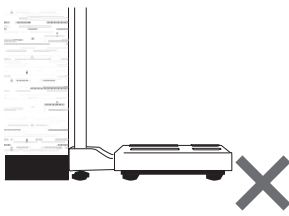
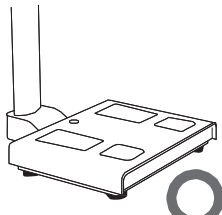
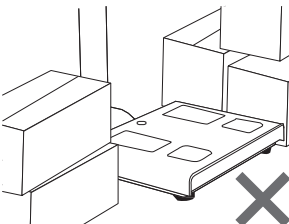
| | |
|--|--|
| <p>placed on hard surface</p>  | <p>placed on carpet</p>  |
| <p>flat surface</p>  | <p>uneven surface</p>  |
| <p>keep space between the wall</p>  | <p>placed against the wall</p>  |
| <p>clear surroundings</p>  | <p>objects placed around the device</p>  |

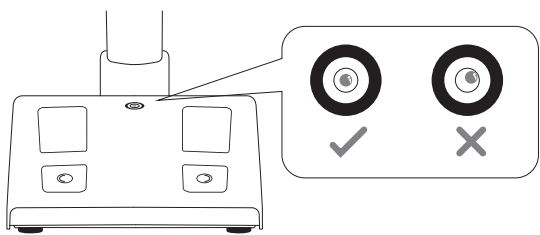

For accurate weight measurement, device should be level.

Level the device by rotating adjustment feet under platform.

(counter-clockwise to lower, clockwise to raise)

3. INSTALLATION

B. Setup

- ⚡ Only use the specified adapter provided by Charder. Using other adapters may result in malfunction or inaccurate readings.

If the device is not plugged into a grounded outlet, electric surges may cause damage, or test results may be affected.

Electrical interference and instability may cause error in test results. Avoid installing the device near products that may create electrical interference.

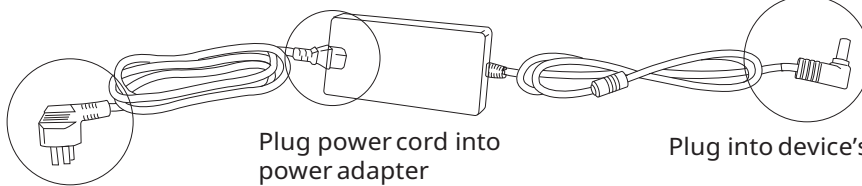
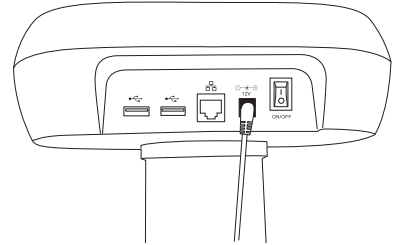

Plug into the mains

Plug power cord into power adapter

Plug into device's power port

C. Optional Accessories

Connecting to scanner

1. Plug scanner's USB Cable into USB port on device
2. Turn on device

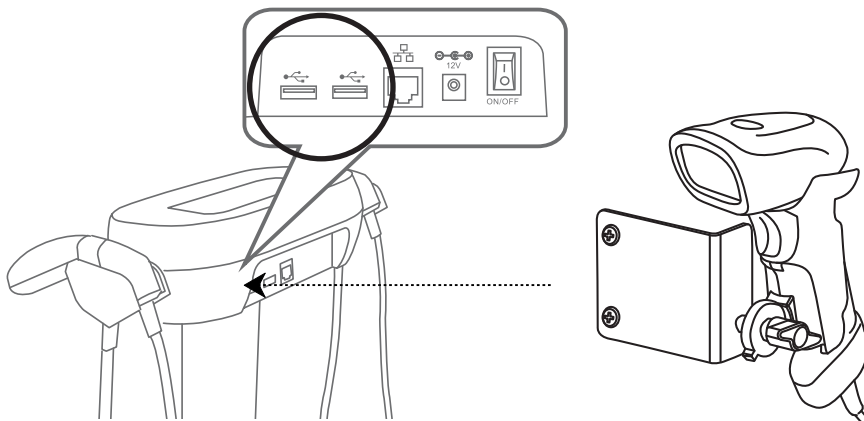

3. INSTALLATION

Connecting to printer

1. Plug printer into mains power
2. Plug printer USB cable into printer
3. Plug printer USB cable into device
4. Turn on printer
5. Turn on device
6. Connect printer in accordance to instructions (p.33 Printer Settings)

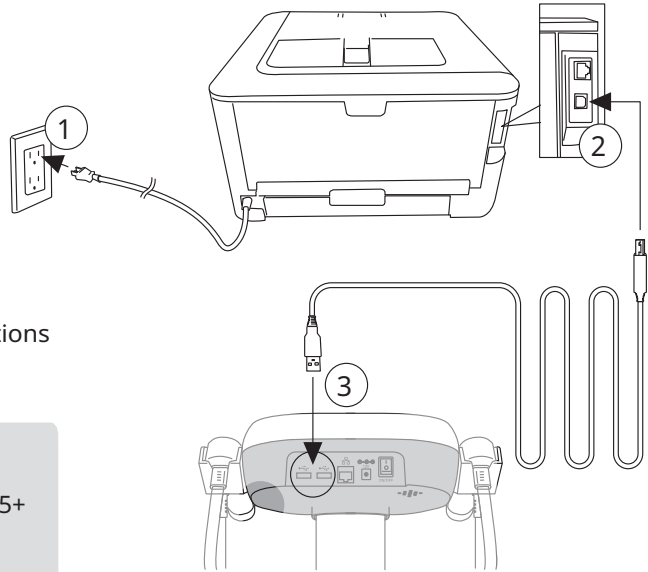

⚠ COMPATIBILITY:

Device is compatible with printers with PCL5+ driver compatibility only.

Connecting to software

1. Plug UA-010 USB Cable into USB ports on device and PC

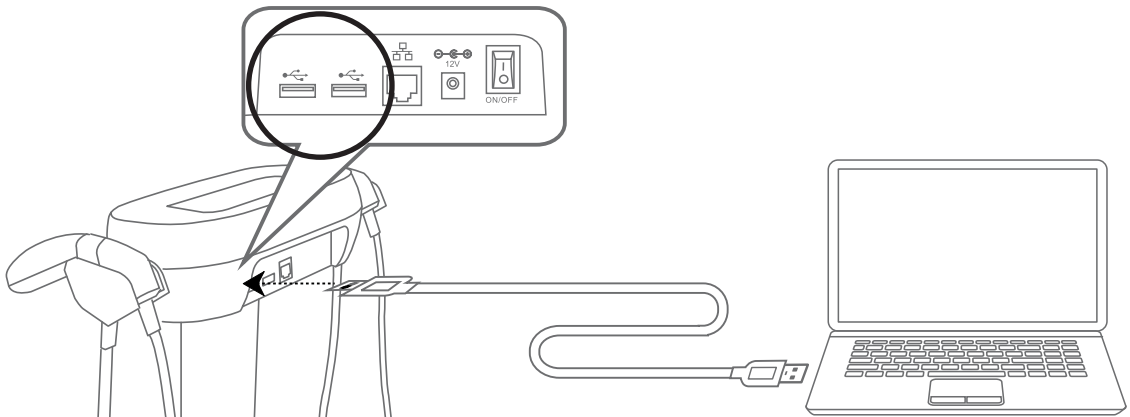

2. Connect software in accordance to instructions (p.37 Data Transfer)

3. INSTALLATION

D. Startup

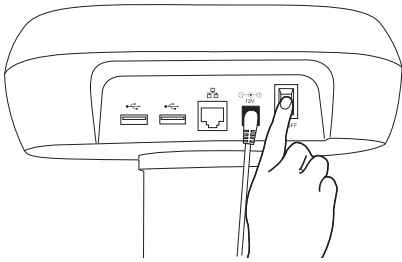

After all accessories have been connected (optional), turn power switch ON to turn on device.

NOTE: After the device has been turned on, you should hear 3 beeps. The screen will remain dark for about 10 seconds. This is normal, and the device will continue self-calibration process.

Device will conduct self-calibration when turning on. The measurement platform should be kept free of objects. Do not stand on platform, or place objects under the device.

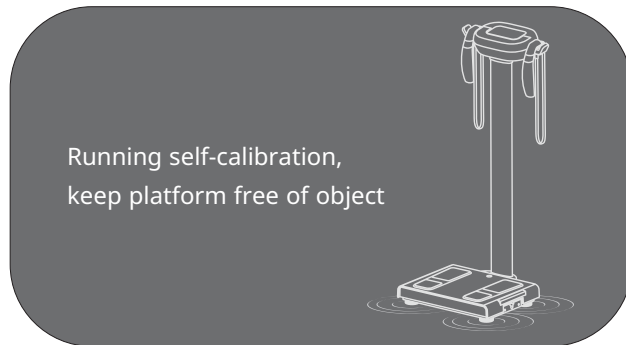

When system self-calibration is complete, the device is ready for use. You will see the start screen below.

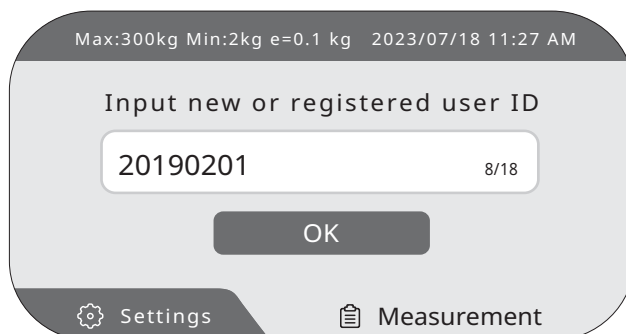

4. BEFORE MEASUREMENT

Warning

Bioelectrical Impedance Analysis impedance measurements should not be used by subjects with the embedded electronic medical devices.

Measurement Guidelines

For best results, Body Composition Analysis should be conducted under specific controlled conditions. Inconsistent measuring conditions will affect the accuracy and validity of BIA results, and interpretation of body composition. The information below regarding the effect of various factors on measurement results is largely sourced from related research by Kushner et al¹.

Before measurement, please take note of the following:

(1) Do not exercise or perform strenuous physical tasks before measurement.

Because BIA analyzes electrical impedance in the body, activities that might affect impedance (e.g. sweating, dehydration, increased blood circulation) such as a heavy workout may cause measurement results to be temporarily less accurate.

(2) Do not eat or drink 2-3 hours before measurement.

Eating and drinking will increase body weight temporarily, and thus affect analysis results. For most accurate results, BIA measurements should be conducted in a fasting state (e.g. before breakfast)².

(3) Do not shower or bathe directly before measurement.

Perspiration can result in a temporary change in body composition measurements, as the accuracy of BIA depends largely upon interpretation of measured impedance values, which are affected greatly by hydration levels.

(4) Perform the measurement under normal temperature conditions (24-28°C)

Extreme temperatures (both hot and cold) can result in temporary physiological changes. For best results, measurements should be conducted in "room temperature", in an environment between 24-28°C / 75-82 °F.

(5) Remove shoes and socks before measurement.

Shoes and socks will interfere with the electric current, making measurement inaccurate or in some cases, impossible.

(6) Avoid physical contact with other people during measurement.

Because BIA measures the impedance encountered as the electric current travels through the subject's body, if another individual is touching the subject, the electric current may pass through the other individual, causing inaccuracy in measurement results.

1. Kushner RF, Clinical characteristics influencing bioelectrical impedance analysis measurements, 1996

2. R Gallagher, M & Walker, Karen & O'Dea, K. The influence of a breakfast meal on the assessment of body composition using bioelectrical impedance. European journal of clinical nutrition. 52. 94-7. 10.1038/sj.ejcn.1600520., 1998.

4. BEFORE MEASUREMENT

(7) Perform the measurement in the morning.

As a general rule, BIA measurements should be performed in the morning to minimize the influence of activity throughout the day on measurements.

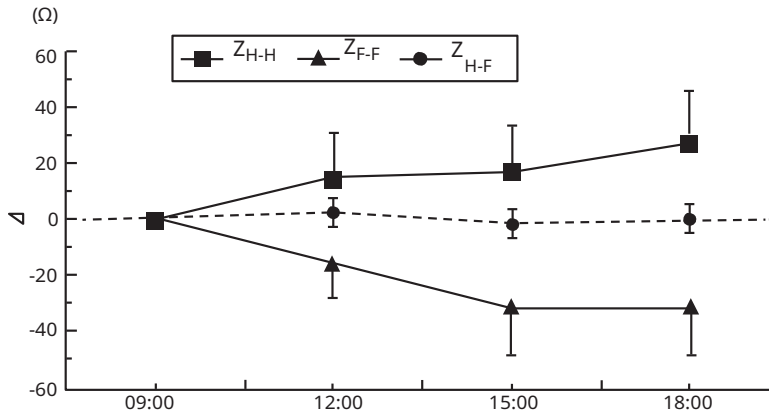

The chart above depicts changes in segmental impedance throughout the day, as reported by Oshima et al. (NOTE: Z_{H-H}, Z_{F-F}, and Z_{H-F} refer to Hand-to-Hand, Foot-to-Foot, and Hand-to-Foot respectively.)³

3. Oshima Y & Shiga T. Within-day variability of whole-body and segmental bioelectrical impedance in a standing position, European Journal of Clinical Nutrition 2006, 60, 938-941

5. MEASURING INSTRUCTIONS

A. Creating / Selecting User

1. Input new or previously registered ID

Press **OK** to proceed.

Max:300kg Min:2kg e=0.1 kg 2023/07/18 11:27 AM

Input new or registered user ID

20190201 8/18

OK

Settings Measurement

NOTE: If ID already exists, user will be brought directly to confirmation screen for verification. (Step 3)

2. Enter user information

Information can be entered **using touchscreen keyboard and/or physical keys.**

(Name, Height, Birthday, Gender, Body Type)

After input/selection, press **Next>** to proceed.

CREATE ACCOUNT

ID 20190201

Please enter your Name

Steven 6/18

Next >

3. Verify profile

If changes are needed, please press on the information to be edited. Once all information is correct, press **Confirm** to proceed.

← CREATE ACCOUNT

Please verify your profile

ID 20190201

Steven Male

182.5 cm 1987.05.02

Confirm

5. MEASURING INSTRUCTIONS

B. Measurement

1. Weight measurement

After profile has been verified, subject should step onto the device for weight measurement. Avoid moving or speaking during measurement. Once weight measurement has stabilized, the weight measurement result (**bold numbers**) will flash several times on the screen.

Clothing weight deduction (optional):

Press the **Clothes Weight** button and set deduction amount.



2. Pre-test check

After weight measurement is complete, device will direct subject to assume correct posture.

(Refer to “Chapter 5.C. Measurement Posture”)

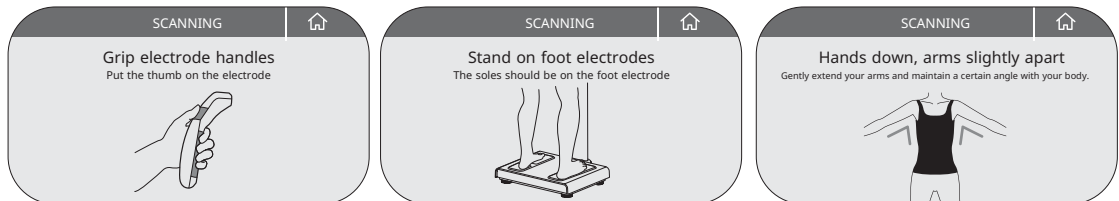

Device will confirm if electrodes are in proper contact. Measurement will not begin if proper contact has not been made.

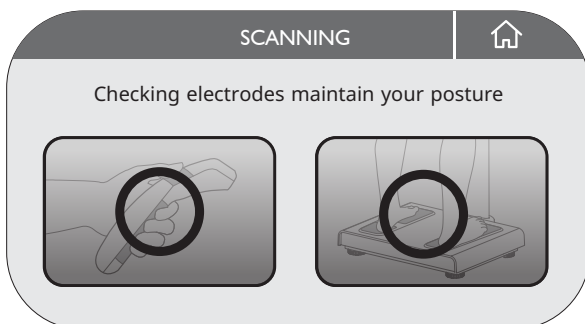

5. MEASURING INSTRUCTIONS

3. Bioelectrical impedance measurement

The device will begin scanning the subject to analyze body composition.

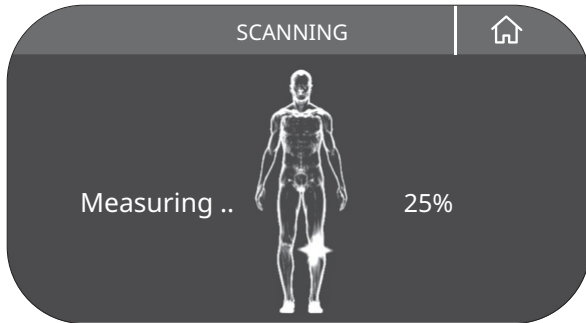

After measurement is completed, place hand electrodes back into holders. Basic results will be displayed on the LCD screen.

Press "Print Results" to print out Result Sheet if printer is connected.

Press "Share" icon to display QR code for scanning by app.



5. MEASURING INSTRUCTIONS

C. Measurement Posture

For accurate results, proper posture is required. Device will automatically begin measurement once correct electrode contact is confirmed.

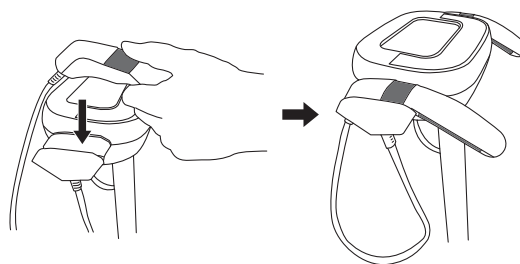
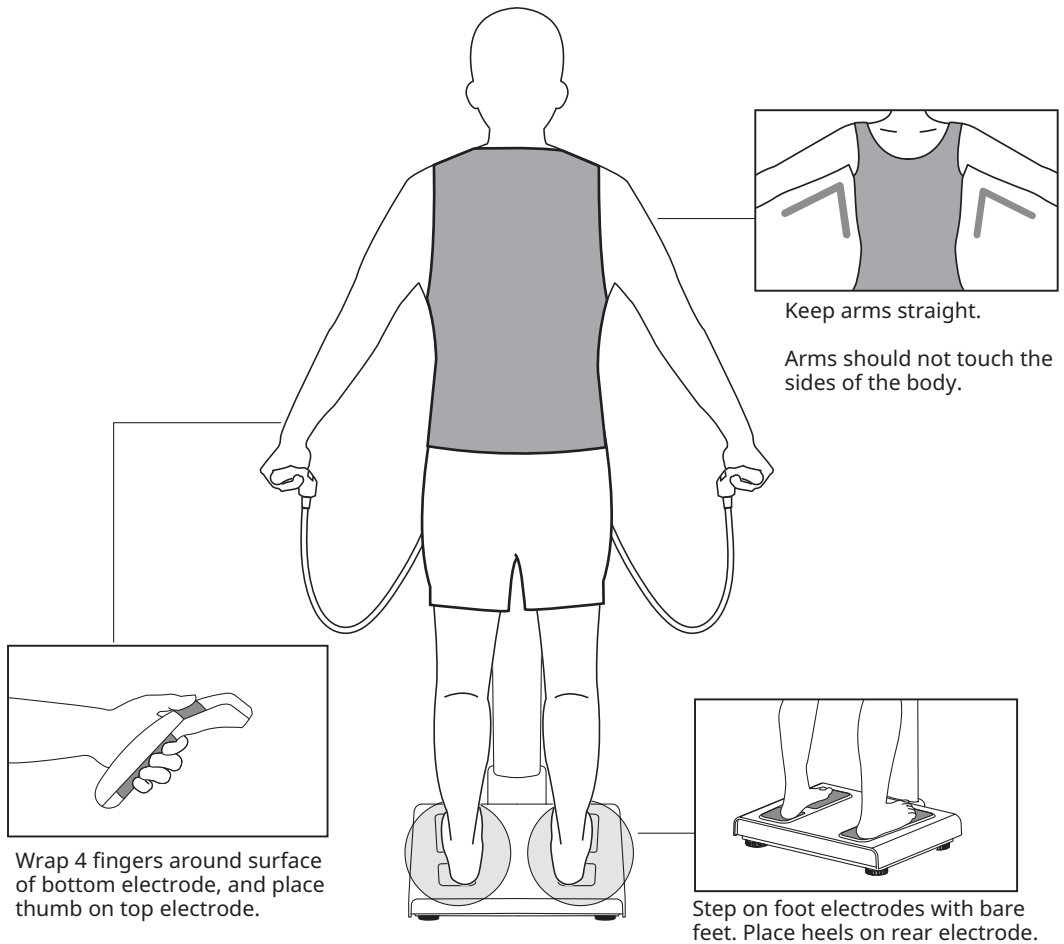

Hand electrodes should be placed back into holders after measurement is completed.

5. MEASURING INSTRUCTIONS

NOTE:

Examples of incorrect posture during measurement

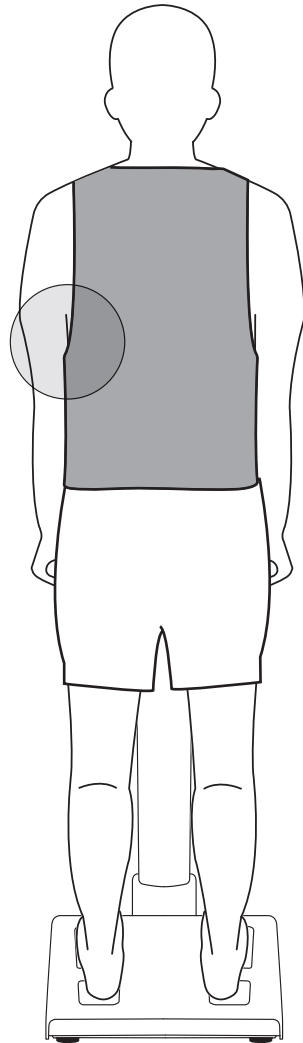

Arms pressed against body

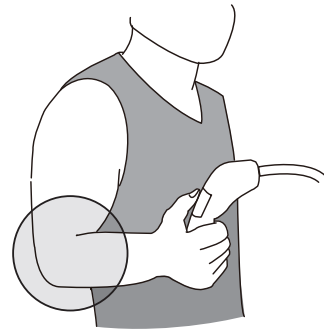

Arms bent

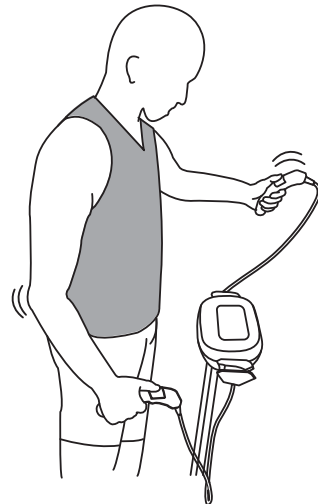

Movement during measurement

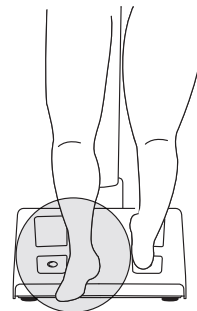

Leaving platform during measurement

5. MEASURING INSTRUCTIONS



Examples of incorrect foot electrode contact

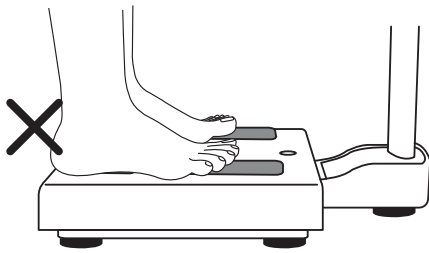

Feet are not in full contact with forward electrodes.

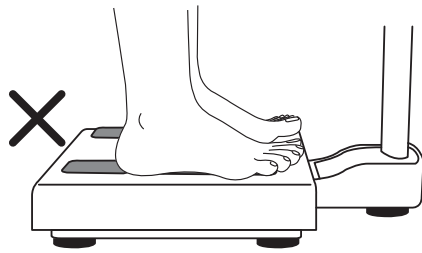

Feet are not in full contact with rear electrodes

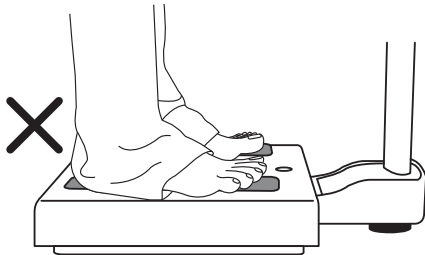

Heels are obstructed from full contact with rear electrodes due to clothing.

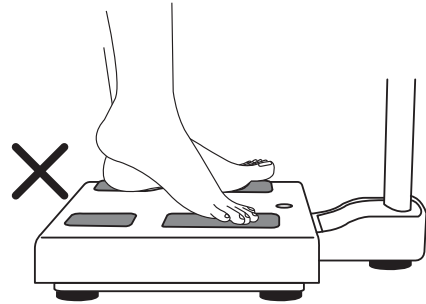

Feet are not in full contact with rear electrodes



Examples of incorrect hand electrode contact

Thumb is not in contact with thumb electrode.

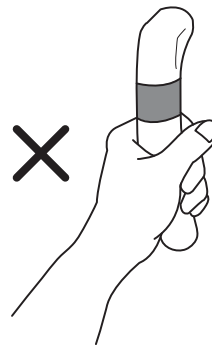
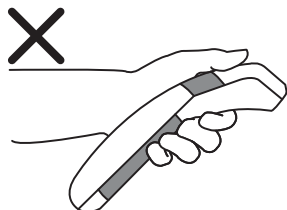
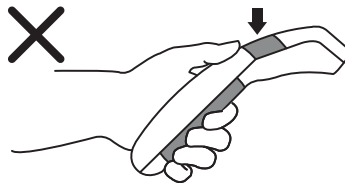

6. SETTINGS

Entering Settings

1. Press **Settings** button on screen

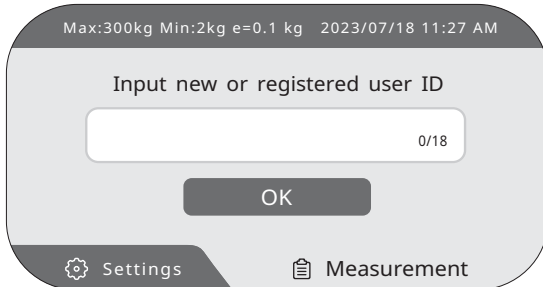

2. Input password [default password: 0000] and press **Login** to enter Settings .

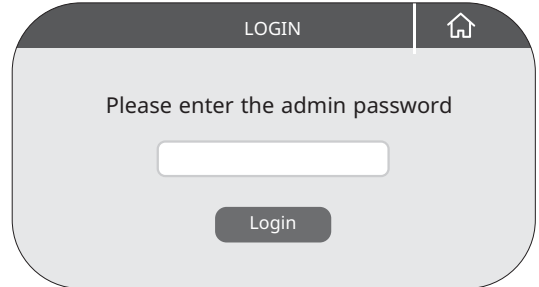

Environment: Device Information (Storage, Network, Software/Hardware Info)



Region: Date/Time, Timezone, Date Format, Time Format, System Language



Printer: Printer Setup, Paper Selection, Paper Alignment, Test Print



Report: Result Sheet Selection, Adjustable Standards, Custom Result Sheet Logo



Data manager: Search / Delete / Export / Print Measurement Data



Network: Manage Wi-Fi / Ethernet functions



Measurement: Default Ethnicity / Body Type, Unit (Metric / Imperial), Clothing Weight Adjustment



Volume: Set system volume



Security: Set and change device password (used for entering Settings menu)



Ads Settings: Adjust optional autoplay video settings



Data Transfer: Data transfer method

6. SETTINGS



Environment: Device Information (Storage, Network, Software/Hardware Info)

This information should be provided when troubleshooting.

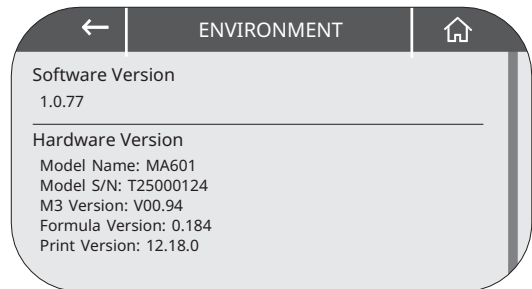
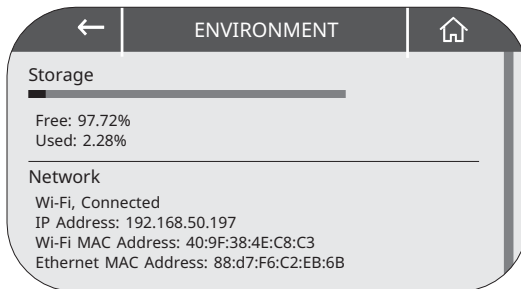

Region: Date/Time, Timezone, Date Format, Time Format, System Language

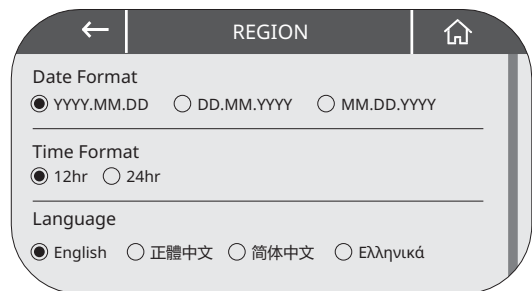
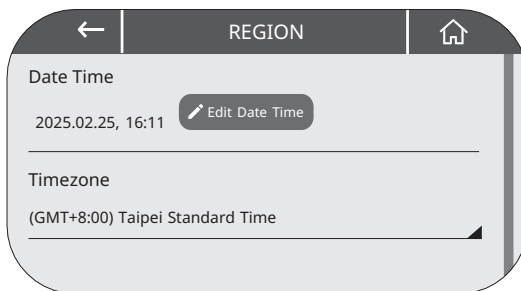

6. SETTINGS



Printer: Printer Setup, Paper Selection, Paper Alignment, Test Print

Press **Search Printer** to pair with printer currently connected to device.

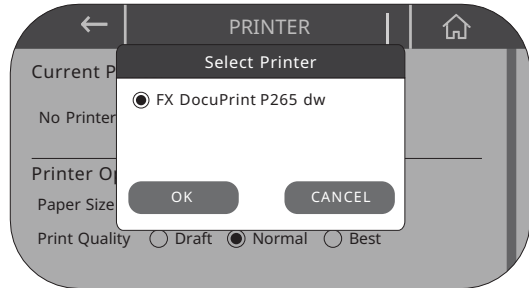

⚠ COMPATIBILITY:

Device is compatible with printers with PCL5+ driver compatibility only.

If error message appears when printer drivers are being installed, please turn on Wi-Fi (see "Network") and connect to the internet. After doing so, press **Search Printer** again. Device will automatically download and install printer drivers.

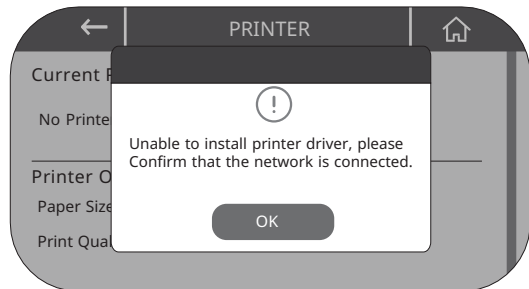

Adjust print alignment

Use the arrow buttons to adjust print position. To move the alignment dot up, press "up" (the same applies for all other directions). Each press will move print position by 0.1 mm. Once positioning dot is centered, paper is fully aligned.

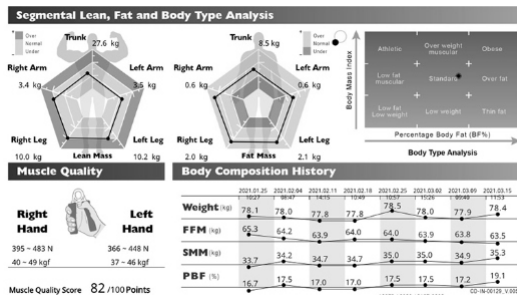
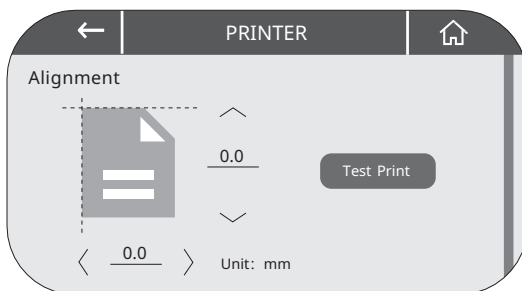

Offset

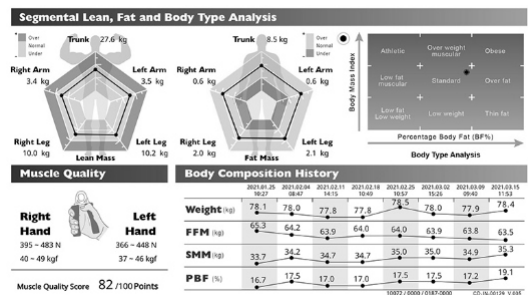

Correctly aligned

6. SETTINGS



Report: Result Sheet Selection, Adjustable Standards, Custom Result Sheet Logo

Child Result Sheet

(If applicable) Leave “Child Age Range” box unchecked to use Default Result Sheet for all ages.

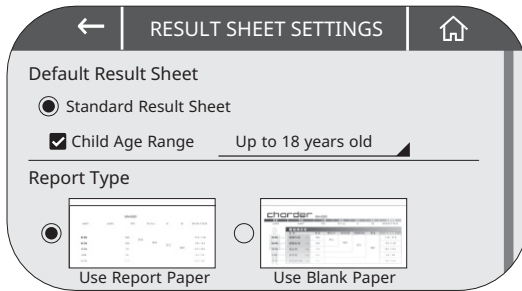

Report Type

Select whether to print result sheet using report paper or blank paper.

Report Paper: select when using Charder Result sheets

Blank Paper: select when using blank paper

BMI / Body Fat / Child Growth Standard

Select preferred normal range most applicable to usage requirements.

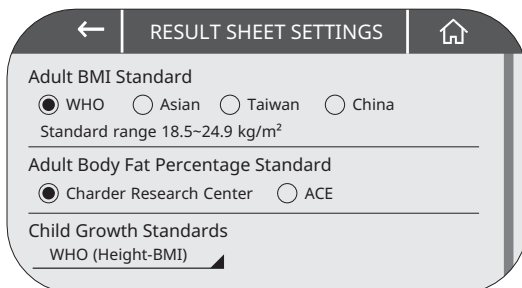

Company Logo

To display custom logo on Result Sheet, save image into USB drive, and plug USB drive into device. Press **Select Image**, choose image from USB drive, and press OK to confirm.



Supported image formats:

JPG, PNG, BMP (dimensions: 1982x316 pixels)

Alternatively, select **Text** can be input text.

6. SETTINGS



Data manager: Search / Delete / Export / Print Measurement Data

Exporting Results

Insert applicable device (ex: Printer / USB drive) to save / export data.

Input ID / name and press **SEARCH** to filter results

Filter results by date using pop-up calendar (Fig.1)

After selecting desired date range, press **SEARCH**

Press to display basic measurement results (Fig.2)

Select individual result(s)

Print result(s)

Save PDF to USB drive

User ID / Name

Save CSV to USB drive

Fig 1: Pop-up calendar

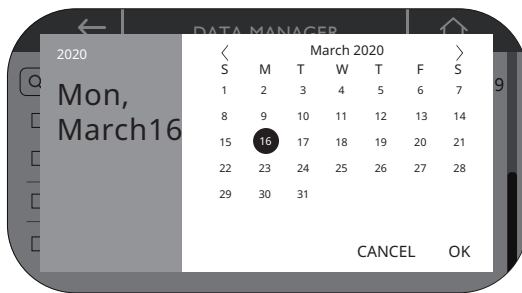
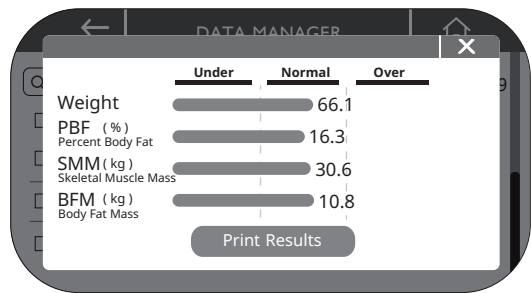

Fig 2: Basic Body Composition Analysis Results



6. SETTINGS



Network: Manage Wi-Fi / Ethernet functions

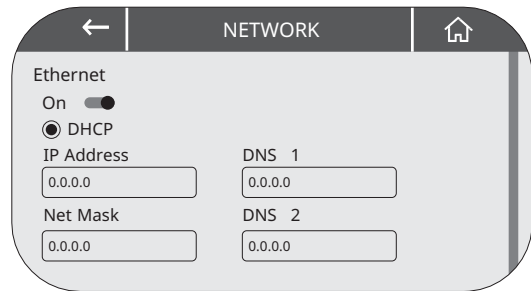
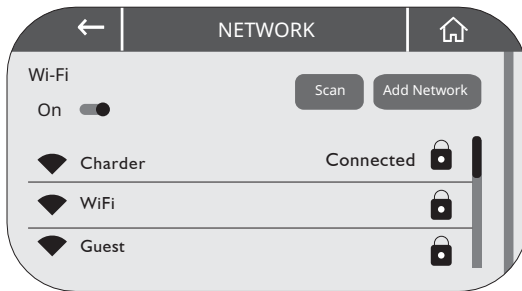

Measurement: Default Ethnicity / Body Type, Unit (Metric / Imperial), Clothing Weight Adjustment

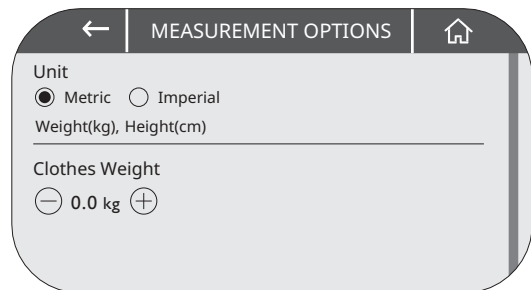
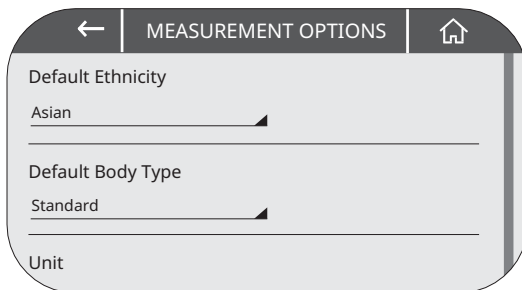

Volume: Set system volume

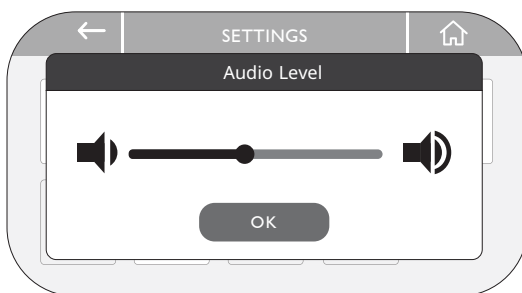

Security: Set device password (used for entering Settings menu)

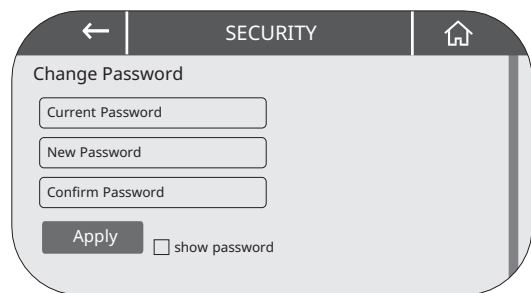

Note: Be careful not to forget the password. If you have forgotten the password, please contact distributor for support.

6. SETTINGS



Ads Settings: Adjust optional autoplay video settings

To play video after device has remained idle, turn Ads Settings Mode **On**.

Uploading video into device

To play custom video on device, save video into USB drive, and plug USB drive into device. Press **Select Media**, choose video from USB drive, and press OK to confirm.

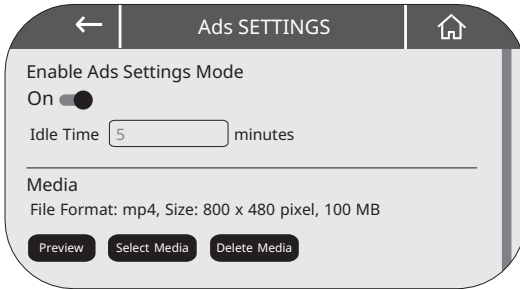

If video does not begin playing after designated amount of time, please confirm that video meets file conditions (MP4 format, 800 x 480 pixel, less than 100 MB).



Data Transfer: Data transfer method

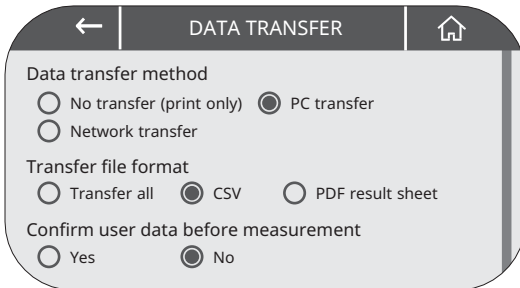

Connect to PC software

1. Select **PC transfer** in “Data transfer method”.
2. Select **CSV** in “transfer file format”.
3. Return device to home screen.
4. Confirm UA-010 USB cable is connected to device and PC.

(for additional details, please consult PC Software user manual)

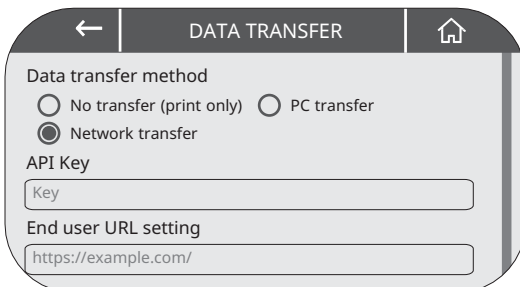

Connect to wireless server

1. Select **Network transfer** in “Data transfer method”.
2. Input API key and End user URL according to server settings.

(for additional details, please contact distributor)

7. FREQUENTLY ASKED QUESTIONS

A. Common Problems

Measurement result is not sent to PC software.

1. Confirm that UA-010 cable is plugged into device and PC.
2. Check if PC software version is compatible with device version.
3. Confirm that measurement was initiated on PC software, not device (depending on software used)

Measurement does not complete

1. Read error message and follow instructions.
2. Subject may have let go of hand electrodes before measurement completion.
3. Subject may have stepped off of platform before measurement completion.
4. Subject's skin may be too dry / calloused. Wet hands/feet with tissue and try again.
5. Ensure that proper measurement posture was followed.

Printing Error

1. Confirm that device and printer are connected using printer's USB cable.
2. Confirm that printer has been correctly installed and printer drivers have been downloaded.
3. Restart printer, wait until printer is ready, and try again.
4. Confirm that printer has PCL5+ compatibility.

B. About Measurement

Are there subjects that should not be measured using this device?

Subjects with implanted electronic medical devices (ex: pacemakers) should not use devices utilizing Bioelectrical Impedance Analysis (BIA), including this device.

A low level electric current will be sent through the body during measurement, which could interfere with the implanted device.

Subjects with metal implants can conduct measurements safely, but measurement results may be affected by metallic material.

Is BIA measurement harmful to the body?

Aside from users with implanted medical device, no scientific research has been published cautioning against bioelectrical impedance analysis. Charder's devices are certified to various national medical standards to ensure safety and effectiveness.

How often should a measurement be conducted?

Changes in body composition due to diet, training, and other activity are not immediate. For effective Tracking of progress, measuring every 2-4 weeks is recommended.

Can jewelry, watches, or other metallic ornaments be worn during measurement?

Metal objects may interfere with the electrical current used during testing, affecting measurement accuracy. In addition, heavy clothing or accessories (if weight is not deducted) will affect weight results, which in turn affects body composition results.



8. SPECIFICATIONS

| | |
|------------------------------|--|
| Measurement method | Multi-frequency Bioelectrical Impedance Analysis |
| Electrodes | Eight electrodes |
| Frequency | Three frequencies |
| Frequency range | 5 kHz, 50 kHz, 250 kHz |
| Display | 800 x 480 pixels, 7 inch Wide color LCD |
| Capacity | 300 kg |
| Graduation | 0.1 kg |
| Accuracy | Impedance \pm 3% |
| Applicable age | 6 ~ 85 years old |
| Input device | Touch screen, Key pad |
| Output device | USB x 2 Note: Device should be connected to network by qualified distributors only. |
| Transmission device | Wi-Fi x 1, RJ45 Ethernet x 1, Bluetooth x 1 (optional) Note: Device should be connected to network by qualified distributors only. |
| Dimensions | 580(L) x 450(W) x 1025(H) mm |
| Weight | About 12 kg |
| Measuring time | Less than 45 secs |
| Outputs | Weight, Body Mass Index (BMI) Skeletal Muscle Mass, Extracellular Water (ECW), Intracellular Water (ICW), Total Body Water (TBW), ECW/TBW, Body Fat, Percent Body Fat (PBF), Metabolic Rates (Basal Metabolic Rate, Total Energy Expenditure), Segmental Lean Mass, Segmental Fat Mass, Visceral Fat Level, Body Type Analysis, Weight Control, Fat Control, Muscle Control, Body Balance, Health Score, Fat-Free Mass (FFM), Fat Mass Index (FMI), Fat-Free Mass Index (FFMI), Skeletal Muscle Index (SMI), Appendicular Skeletal Muscle Index (ASMI), Grip Strength, Protein, Minerals, Soft Lean Mass, Waist-Height Ratio, Growth Chart, Growth History, Evaluation & Recommendations, Impedance, Phase Angle, Core Muscle, Fitness Score |
| Electrode current | < 500 μ A |
| Power supply | Manufacturer: FUHUA ELECTRONIC Model: UES48-120300SPA3 Input AC 100~240V, 50/60Hz, 2.0A Output DC 12.0V, 5.0A adapter |
| Printing device | USB port |
| Measuring range | 100 ~ 950 Ω |
| Operation environment | +41 ~ +95°F (+5 ~ +35°C) , 30 ~ 75% RH , 70 ~ 106 kPa 700 hPa ~1060 hPa |
| Voice guidance | Voice guidance throughout entire measuring process |
| Result sheet | Standard, Fitness, Child (A4 or Letter size) |

* For purpose of product improvement, specifications are subject to change without prior notice.

Declaration of Conformity

This product has been manufactured in accordance with the harmonized European standards, following the provisions of the below stated directives:

| | |
|---|--|
|  | (EU) 2017/745 Regulation on Medical Devices |
|  | 2014/31/EU Non-automatic Weighing Instruments Directive |

RoHS Directive 2011/65/EU and Delegated Directive (EU) 2015/863

Radio Equipment Directive 2014/53/EU

Part 15 of the Federal Communications Statement Rules

This device may not cause harmful interference.

This device must accept any interference received, including interference that may cause undesired operation.

(Full Declaration of Conformity is available on manufacturer's website)

Please see separate document showing on sticker of device for above markings.

Authorized EU Representative:



Obelis s.a.
Bd Général Wahis, 53
B-1030 Brussels
Belgium



Charder Electronic Co., Ltd.

No.103, Guozhong Rd., Dali Dist., Taichung City 41262

Taiwan TEL: +886 4 2406 3766 FAX: +886 4 2406 5612

Email: info_cec@charder.com.tw

www.chardermedical.com